

Measurement Guide

OBSAI RF Analyzer

for Anritsu RF and Microwave Handheld Instruments

OBSAI – Open Base Station Architecture Initiative

The Anritsu logo consists of the word "Anritsu" in a bold, sans-serif font. The letter "A" is stylized with a diagonal slash through it. The logo is positioned in the bottom right corner of the page.

Trademark Acknowledgments

BTS Master is a trademark of Anritsu Company. Acrobat is a registered trademark of Adobe Corporation.

Notice

Anritsu Company has prepared this manual for use by Anritsu Company personnel and customers as a guide for the proper installation, operation and maintenance of Anritsu Company equipment and computer programs. The drawings, specifications, and information contained herein are the property of Anritsu Company, and any unauthorized use or disclosure of these drawings, specifications, and information is prohibited; they shall not be reproduced, copied, or used in whole or in part as the basis for manufacture or sale of the equipment or software programs without the prior written consent of Anritsu Company.

Updates

Updates, if any, can be downloaded from the Anritsu Website at:

<http://www.anritsu.com>

For the latest service and sales contact information in your area, please visit:

<http://www.anritsu.com/contact-us>

Notes On Export Management

This product and its manuals may require an Export License or approval by the government of the product country of origin for re-export from your country.

Before you export this product or any of its manuals, please contact Anritsu Company to confirm whether or not these items are export-controlled.

When disposing of export-controlled items, the products and manuals need to be broken or shredded to such a degree that they cannot be unlawfully used for military purposes.

Product Information, Compliance, and Safety

Read the Handheld Instruments Product Information, Compliance, and Safety Guide (PN: 10100-00065) for important safety, legal, and regulatory notices before operating the equipment. For additional information and literature covering your product, visit the product page of your instrument and select the Download Library tab.

Table of Contents

Chapter 1—General Information

1-1	Introduction	1-1
1-2	Selecting a Measurement Mode	1-1
1-3	Contacting Anritsu	1-2

Chapter 2—OBSAI Analyzer

2-1	Introduction	2-1
2-2	Setup Requirements and Checklist	2-2
2-3	Typical OBSAI Connection	2-3
2-4	OBSAI Configuration	2-4
	Link Rate	2-4
	RP3 Address	2-4
	LTE Bandwidth	2-5
2-5	OBSAI Measurement Display	2-5
	OBSAI Spectrum	2-6
	Spectrogram	2-7
2-6	OBSAI Configuration Example	2-8
2-7	OBSAI Analyzer Menu Map	2-9
	Measurements Menu Map	2-11
	Sweep Menu	2-13
	Trace Menus	2-13
	Limit Menu	2-14
2-8	Freq Menu	2-15
2-9	Span Menu	2-18
2-10	Amplitude Menu	2-19
2-11	Units of External Gain or Loss	2-19
2-12	Bandwidth Menu	2-20
2-13	Measure Menu	2-21
2-14	OBSAI Config Menu	2-23
2-15	Display Config Menu	2-24
2-16	Carrier Trace Config Menu	2-25
2-17	Carrier Trace Menu	2-26
2-18	OBSAI Spectrum Menu	2-27
2-19	Spectrogram Menu	2-28
2-20	Display Setup Menu	2-29

Table of Contents (Continued)

2-21	OBSAI SFP Data Menu	2-31
2-22	Marker Menu	2-33
2-23	Marker 2/2 Menu	2-35
2-24	Sweep Menu	2-36
2-25	Trace Menu	2-37
2-26	Trace A Ops Menu	2-38
2-27	Trace B Ops Menu	2-39
2-28	Trace C Ops Menu	2-40
2-29	Limit Menu	2-41
2-30	Limit Move Menu	2-42
2-31	Save Menu	2-43
2-32	Save Location Menu	2-45
2-33	Recall Menu	2-47

Index

Chapter 1 — General Information

1-1 Introduction

This measurement guide describes the OBSAI (Open Base Station Architecture Initiative) Analyzer test and measurement functions of Anritsu RF and Microwave Handheld Instruments. Basic spectrum analyzer functions are documented in the Spectrum Analyzer Measurement Guide. Other functions are available only when the related option is installed and activated. These features are documented in their respective Measurement Guides. Refer to the instrument User Guide for a list of options and their related manuals.

Screen captured images contained in this document are provided as examples. Illustrations of menu maps, or menu trees, may show submenu keys that display only under certain conditions. The actual displays, screen menus, and measurement details may differ based on instrument model, firmware version, installed options, and current instrument settings.

1-2 Selecting a Measurement Mode

To switch from the current measurement mode, or application, to another:

1. Press the **Shift** front panel key, followed by **Mode (9)**. The Mode Selector dialog opens.
2. Use the arrow keys or rotary knob, or tap the touch screen to highlight the desired measurement mode. The list of available applications depends on the options that are installed and activated on your instrument. See [Figure 1-1](#).
3. Press **Enter**.

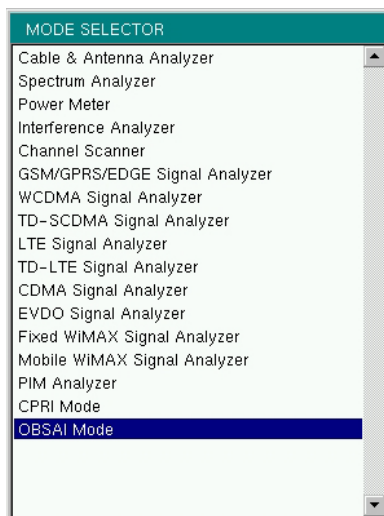


Figure 1-1. Mode Selector Dialog Box

On instruments that have a front panel **Menu** key, an alternate method of changing the measurement mode is to press **Menu**, then press the appropriate application icon on the touch screen.

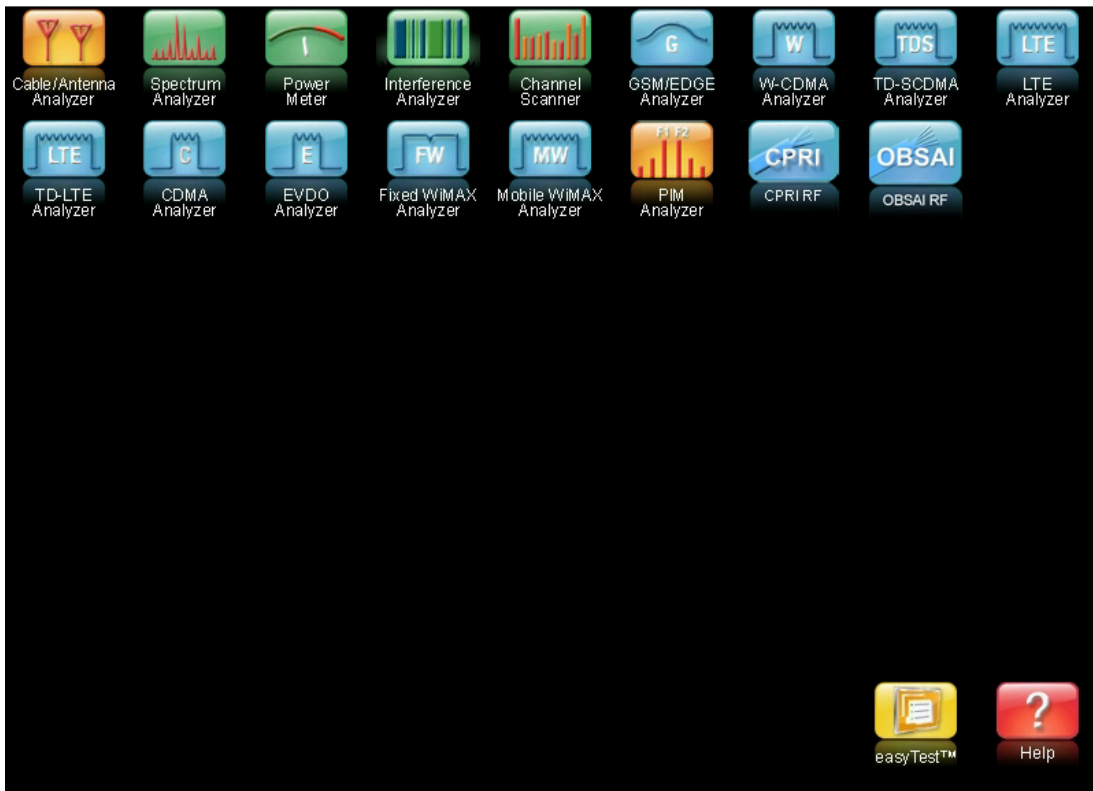


Figure 1-2. Menu Key Screen – Application Icons and User-Defined Shortcuts

1-3 Contacting Anritsu

To contact Anritsu, please visit:

<http://www.anritsu.com/contact-us>

On this page, you can find links to sales, service, and support contact information for your country or region. You can also provide online feedback, complete a “Talk to Anritsu” form to have your questions answered, or obtain other services offered by Anritsu.

Updated product information can be found on the Anritsu website:

<http://www.anritsu.com/>

Search for the product model number. The latest documentation is on the product page, under the Library tab.

Chapter 2 — OBSAI Analyzer

2-1 Introduction

The Open Base Station Architecture Initiative (OBSAI) specifications define a set of requirements for a wireless base transceiver station (BTS). Reference Point 3 (RP3) within the OBSAI specifications defines the digital interface between the Base Band Module (BBM) and the Radio Frequency Module (RFM). This is an alternative to the traditional Radio Frequency (RF) coaxial connection, or the CPRI digital interface.

Anritsu's OBSAI Analyzer (Option 753) allows users to make RF-based measurements over a fiber optic OBSAI link to look for interference problems affecting an RFM. This is accomplished by tapping into the fiber link between the RFM and BBM, using an optical splitter to connect to the Anritsu test instrument. The instrument will decode the OBSAI protocol IQ data and convert it to RF data.

Note

Option 753 requires Option 759, RF over Fiber Hardware. Depending on your Anritsu test instrument model, Option 759 may have a single or dual SFP ports. Refer to your instrument Technical Data Sheet for specifications.

Screen displays vary with the installed option and instrument model being used. The screen captures illustrated in this document are examples and may differ from your instrument display.

The main differences between OBSAI and traditional RF signals are summarized in [Table 2-1](#).

Table 2-1. OBSAI Signal Characteristics (Compared to RF)

RF	OBSAI
Analog	Digital
Absolute measurements	Relative measurements
dBm	dB
Specific center frequency	Base Band
Absolute power levels	Relative power levels
Full Span capable	Max Span = Carrier BW + 50%

Two types of OBSAI measurements are available:

- Spectrum mode is typically used to test the OBSAI link in real time.
- Spectrogram mode lets users monitor for intermittent interference over a specifiable recording time.

These OBSAI Analyzer test and measurement functions can be performed from ground level, eliminating the risk and costs of climbing towers. [Figure 2-1](#) illustrates a typical connection configuration for OBSAI testing with an Anritsu test instrument.

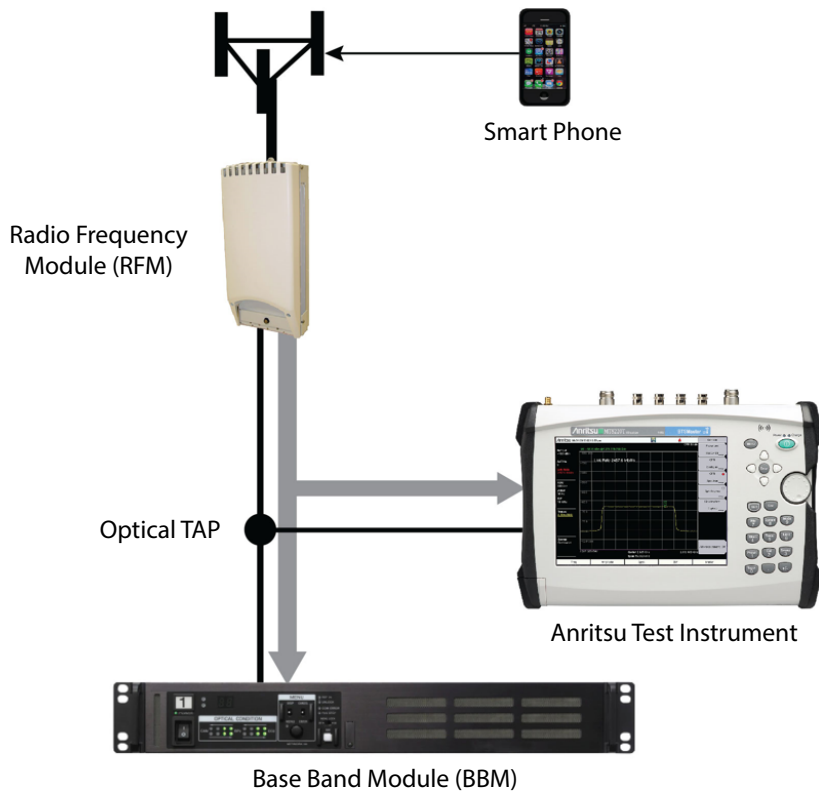


Figure 2-1. Connection Configuration for OBSAI Testing with Anritsu Test Instrument

2-2 Setup Requirements and Checklist

Following is a list of accessories and questions to be answered to successfully set up an OBSAI connection for testing:

- SFP optical transceiver used to connect the measurement device must match the link rate of SFPs on the BBM and RFM. Different instrument models are available from Anritsu, with single or dual SFP ports.
- Optical splitter or TAP (Test Access Point), Single Mode or Single/Multi Mode
- Optical cables
- Who is the network equipment manufacturer (NEM)?
- Is the fiber optic connection Single Mode (Yellow) or Multi Mode (Orange)?

Required accessories are available from Anritsu Company. Refer to the instrument Technical Data Sheet.

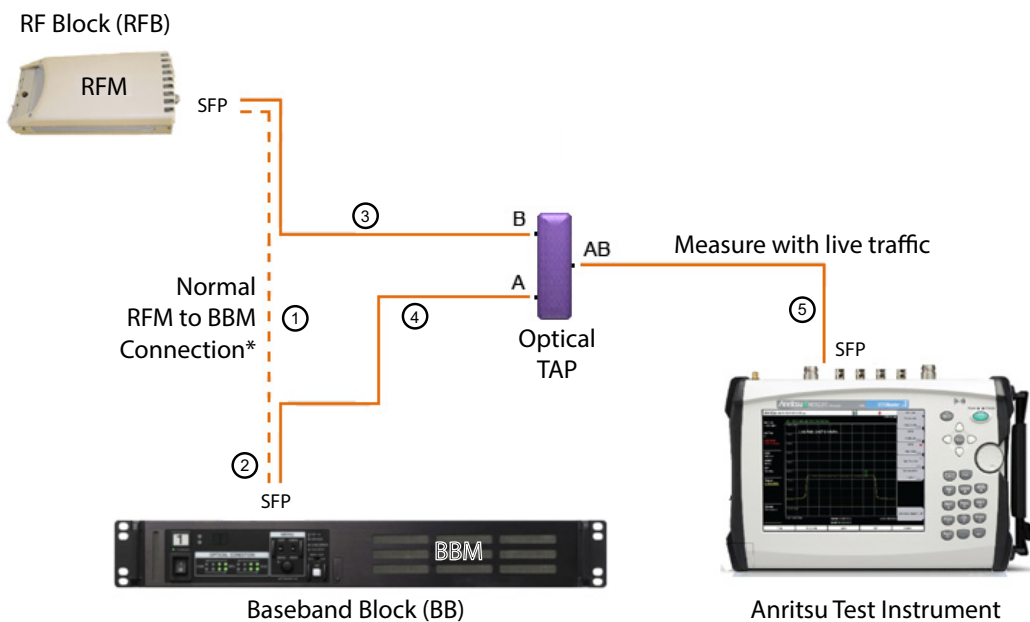
2-3 Typical OBSAI Connection

1. Lock down the RFM before disconnecting the fiber optic cable.
2. Disconnect the fiber cable from the BBM.
3. Connect the RFM to Port B on the optical TAP.
4. Connect a 3-meter LC/LC Duplex Jumper from Port A on the optical TAP to the BBM.
5. Use a compatible SFP transceiver and Simplex fiber cable to connect the Anritsu test instrument to Port AB on the optical TAP.

Port A Out from Port AB is the downlink BBM signal.


Port B Out from Port AB is the uplink RFM signal.

6. If your test instrument has dual SFP ports, you can optionally connect it to another RFM, using the second port.
7. When all connections are complete, unlock the RFM.
8. Perform measurements using live traffic.



* Lock down the Radio before disconnecting fiber from BBM

Figure 2-2. Connecting OBSAI Link to Anritsu Test Instrument

<p>Warning</p> 	<p>Laser radiation may be present at fiber optic cable connectors and ports. This laser radiation could present a nominal ocular hazard from either direct viewing or by diffuse reflection. Do not view the emitted laser radiation directly or indirectly because permanent blindness may result.</p>
-----------------------------------------------------------------------------------------------------------	---------------------------------------------------------------------------------------------------------------------------------------------------------------------------------------------------------------------------------------------------------------------------------------------------------

2-4 OBSAI Configuration

The primary application for OBSAI RF is to check for interference on the RFM-to-BBM uplink. When monitoring traffic over the OBSAI link, the Anritsu test instrument will extract the IQ data and process the signal into data points to be plotted on the instrument screen.

The OBSAI parameters described in this section are needed for the OBSAI Analyzer to process and display the data correctly. Note that configurations may be different for the uplink and downlink. The uplink signal represents mobile phone LTE data. The downlink signal is the display of BBM LTE signals to RFM.

All OBSAI IQ data is at baseband frequency. To allow the OBSAI signal to move off center (pan), turn the Center Frequency Reference setting on and adjust the center frequency to a different value. Depending on the value entered, this may automatically adjust the frequency span, as there cannot be panning without zooming. Refer to [“Freq Menu” on page 2-15](#).

Link Rate

Link Rate is the speed, or bit rate, of the OBSAI link. The instrument automatically sets the link rate when it detects valid OBSAI carriers. On dual-SFP models, the link rate applies to both SFP data streams. [Table 2-2](#) lists the supported link rates and associated rate indices.

Table 2-2. OBSAI Link Rates

OBSAI Rate Index	Link Rate (Mbit/s)
1x	768.0
2x	1536.0
4x	3072.0
8x	6144.0

When the rate index is 8x (6144.0 Mbps), the instrument will automatically detect and display the scrambling seed associated with each SFP link.

RP3 Address

OBSAI Reference Point 3 (RP3) defines the digital interface between the Radio Frequency and Base Band Modules of a base station. Your Anritsu instrument automatically scans for active RP3 addresses in the IQ stream when a new OBSAI link is detected. The RP3 list will then refresh with new addresses found on the SFP link, if any, and the link rate will be set based on the newly plugged in fiber.

You can also initiate a scan by pressing **Start OBSAI** under the Measurements menu. Refer to [“Measure Menu” on page 2-21](#). On instrument models with dual SFP ports, **Start OBSAI** will scan both SFPs.

If **Start OBSAI** detects valid RP3 addresses, it will reset the display to a single Spectrum graph with Carrier Trace 1 displaying the first RP3 address in the available address list. If no OBSAI carriers are found, a message indicating the RP3 address list is empty will display when you attempt to configure a carrier trace with the **RP3 Address** key.

The RP3 list is empty following an instrument power cycle. You must then either establish a new SFP link or run a scan with **Start OBSAI** to obtain valid address entries.

Upon fiber plug-out or when a Loss of Signal (LOS) is detected at an SFP port, RP3 addresses associated with that OBSAI link are dropped from the list. Active addresses associated with the other port (on dual-SFP models) remain available for carrier trace configuration.

Table 2-3 lists the maximum number of antenna-carriers that will fit in an RP3 link, depending on channel bandwidth and link rate.

Note For a carrier trace to display on the instrument screen, its RP3 bandwidth must match the LTE bandwidth set for the currently active display.

Table 2-3. RP3 Link Capacity

LTE Bandwidth	1x	2x	4x	8x
5 MHz	2	4	8	16
10 MHz	1	2	4	8
15 MHz ^a	-	1	2	4
20 MHz	-	1	2	4

a. The Anritsu OBSAI Analyzer only detects LTE carriers in the 15 MHz channel bandwidth when the signals are transmitted in the Dual Bit Map algorithm described in the Message Transmission Rules section of the OBSAI Reference Point 3 Specification, Version 4.2.

LTE Bandwidth

This is the bandwidth of the LTE carrier that is transmitted via OBSAI. Supported LTE carrier bandwidths are 5 MHz, 10 MHz, 15 MHz, and 20 MHz. The maximum span is approximately 50% greater than the carrier bandwidth. For example, if the LTE bandwidth is 10 MHz, the maximum span will be 15 MHz.

The LTE bandwidth is set independently for each of Display 1 and 2 in dual display mode. In spectrum view, the LTE bandwidth of the currently active display is shown on the left side of the sweep window.

When selecting the RP3 address of a carrier trace, the display bandwidth may need to be changed to match the RP3 bandwidth. If prompted, press **OK** in the message box or press **Enter** to change the display's LTE bandwidth.

2-5 OBSAI Measurement Display

Two measurement display modes are available: spectrum and spectrogram. Figure 2-3 and Figure 2-4 show display screens on an Anritsu BTS Master MT8220T loaded with Option 753. The screens and menus on your instrument may differ depending on the model, installed option, and firmware version.

In both display modes, the connection status of the SFP port or ports is displayed on the instrument screen as colored dots above the sweep window. Green indicates a good connection, red indicates an error, and gray (no color) means no connection. The examples below illustrate a dual-SFP instrument screen, with no connection at SFP Port 2.

- LOS – Loss of Signal
- LOF – Loss of Frame

OBSAI Spectrum

Spectrum mode displays signals as a waveform in a traditional spectrum analyzer view.

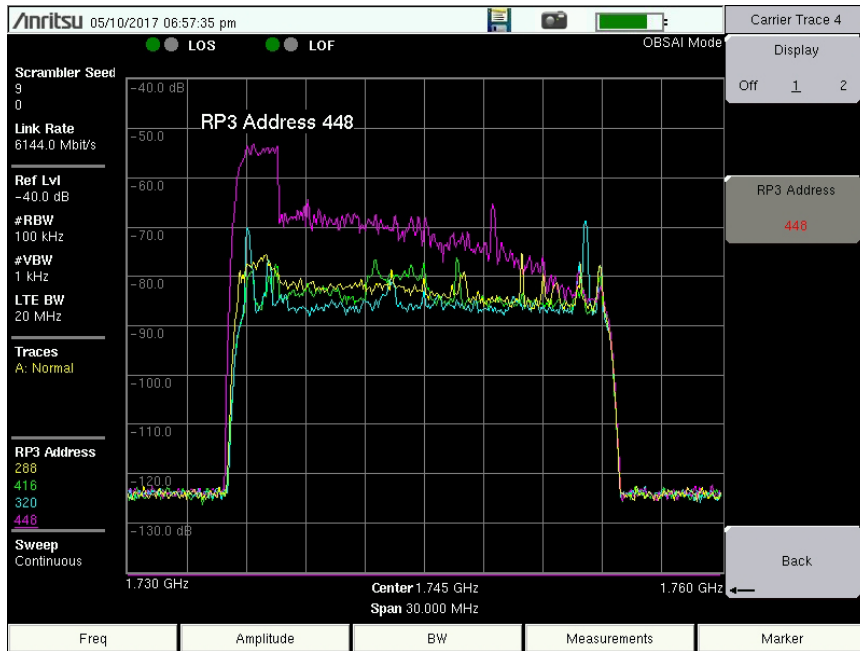


Figure 2-3. OBSAI Spectrum Display

- **Scrambler Seed** – Is the scrambling seed of the OBSAI link when the link rate is 6144.0 Mbps (8x). “NA” is displayed when the link rate is not 6144.0 Mbps.
- **Link Rate** – Is the selected link rate, which applies to both SFPs on dual SFP models.
- **Ref Lvl** – Indicates the maximum amplitude value on the Y-axis, that is, the top grid line, of the sweep window. Refer to [“Amplitude Menu” on page 2-19](#). The value shown is the amplitude reference level of the currently active display: Display 1 or Display 2.
- **RBW** – Is the current resolution bandwidth. When present, a pound sign (#) in front of RBW indicates that the Auto RBW setting is off and the RBW value is or can be set independently of the frequency span. Refer to [“Bandwidth Menu” on page 2-20](#).
- **VBW** – Is the current video bandwidth. When present, a pound sign (#) in front of VBW indicates that the Auto VBW setting is off and the VBW value is or can be set independently of RBW.
- **LTE BW** – Shows the LTE bandwidth of the currently active display. Refer to [“Display Config Menu” on page 2-24](#).
- **Traces** – Displays the Trace A, B, and C Operations settings associated with Trace 1. Refer to [“Trace Menu” on page 2-37](#). These settings are not displayed when Trace 1 is turned off.
- **RP3 Address** – Displays the RP3 address associated with each of the four potential carrier traces. The decimal address values are displayed in the same color as their respective traces. The values are blank for traces that are turned off.
- **Sweep** – Shows the current sweep mode, single or continuous. Refer to [“Sweep Menu” on page 2-36](#).

Spectrogram

A spectrogram is a three-dimensional representation of frequency, time, and power. Color is used to represent the relative power levels. In this view, only one trace is displayed at a time (one on each display in dual display mode).

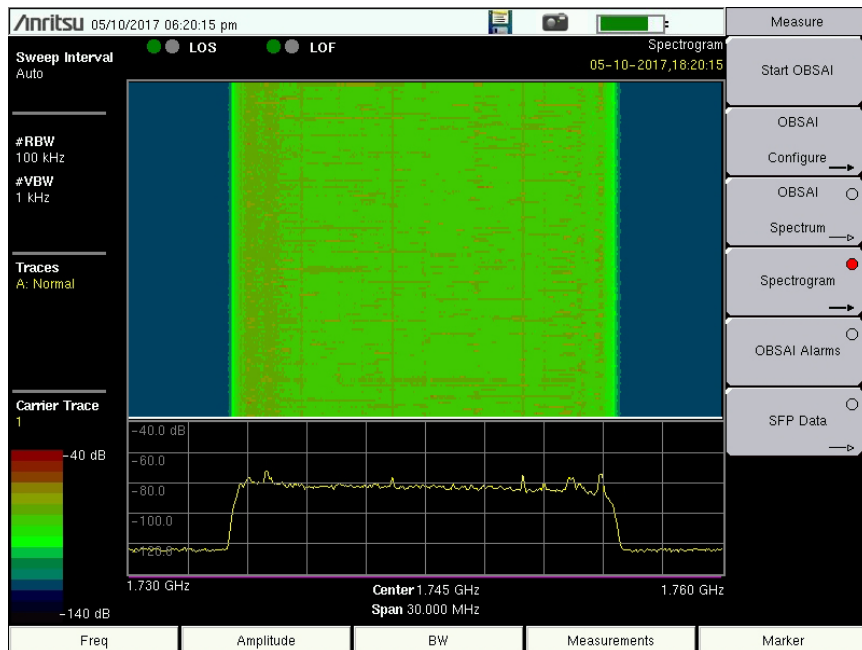


Figure 2-4. OBSAI Spectrogram Display

- Sweep Interval – Shows the sweep interval of the currently active trace. Refer to [“Spectrogram Menu” on page 2-28](#).
- RBW – Is the current resolution bandwidth. When present, a pound sign (#) in front of RBW indicates that the Auto RBW setting is off and the RBW value is or can be set independently of the frequency span. Refer to [“Bandwidth Menu” on page 2-20](#).
- VBW – Is the current video bandwidth. When present, a pound sign (#) in front of VBW indicates that the Auto VBW setting is off and the VBW value is or can be set independently of RBW.
- Traces – Displays the Trace A, B, and C Operations settings associated with Trace 1. Refer to [“Trace Menu” on page 2-37](#). These settings are not displayed when Trace 1 is turned off.
- Carrier Trace – Shows the number of the trace being displayed, N/A if no carrier trace is configured, that is, turned on. In dual display mode, a value is displayed for each of Spectrogram Display 1 and 2. When switching from dual to single mode, the currently active display will be shown as the single display. Refer to [“Display Setup Menu” on page 2-29](#).

2-6 OBSAI Configuration Example

Following is an example of configuring your Anritsu instrument for OBSAI testing on the uplink LTE signal (Port B Out from Port AB on the optical TAP). Your screen display and user menus may differ depending on your instrument model and firmware version.

1. If your test instrument is not in OBSAI measurement mode, press the front panel **Menu** key, then press the OBSAI RF application icon.
2. Press the **Measurements** main menu key at the bottom of the touch screen.
3. Before proceeding to the next step, verify that you have at least one active OBSAI link (LOS and LOF indicators above the trace window are both green). See [Figure 2-5](#).
4. Press **Start OBSAI** to initiate a scan of the OBSAI link for active RP3 addresses and detect the link rate. On dual-SFP instrument models, both links are scanned if active.

If no OBSAI carriers are found, a message indicating that the RP3 address list is empty will display when you attempt to configure a carrier trace in [Step 6](#). Refer to [“RP3 Address”](#) on [page 2-4](#).

5. If valid RP3 addresses are detected, the first address in the list is displayed as Carrier Trace 1 in a Spectrum view similar to [Figure 2-5](#). The display bandwidth is set to match the LTE bandwidth of Trace 1.

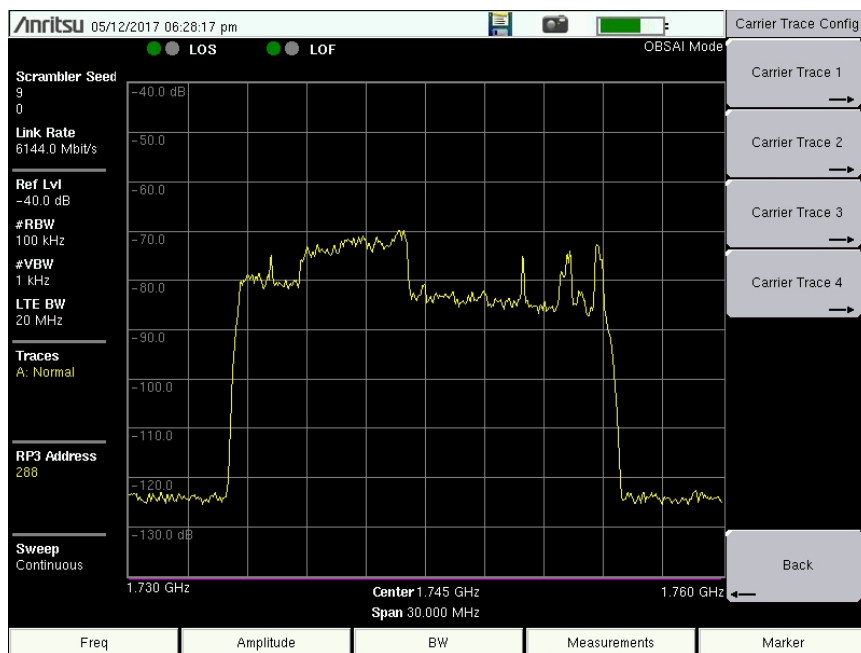


Figure 2-5. Sample Spectrum Display

6. Configure the display and remaining carrier traces as appropriate. Up to four traces can be displayed on a single display, or they may be distributed between the two displays in dual display mode. Refer to [“Carrier Trace Menu”](#) on [page 2-26](#).
7. To change the view to Spectrogram, press the **Measurements** key, then Spectrogram.

Refer to the Spectrum Analyzer Measurement Guide for details on Spectrum Analyzer and Interference Analyzer (Spectrogram) functions.

2-7 OBSAI Analyzer Menu Map

Figure 2-6 and Figure 2-7 illustrate the OBSAI Analyzer main menu map, showing all possible submenu keys, although some keys may be displayed on the instrument only under certain conditions. Additional menus and submenus are shown on the next pages.

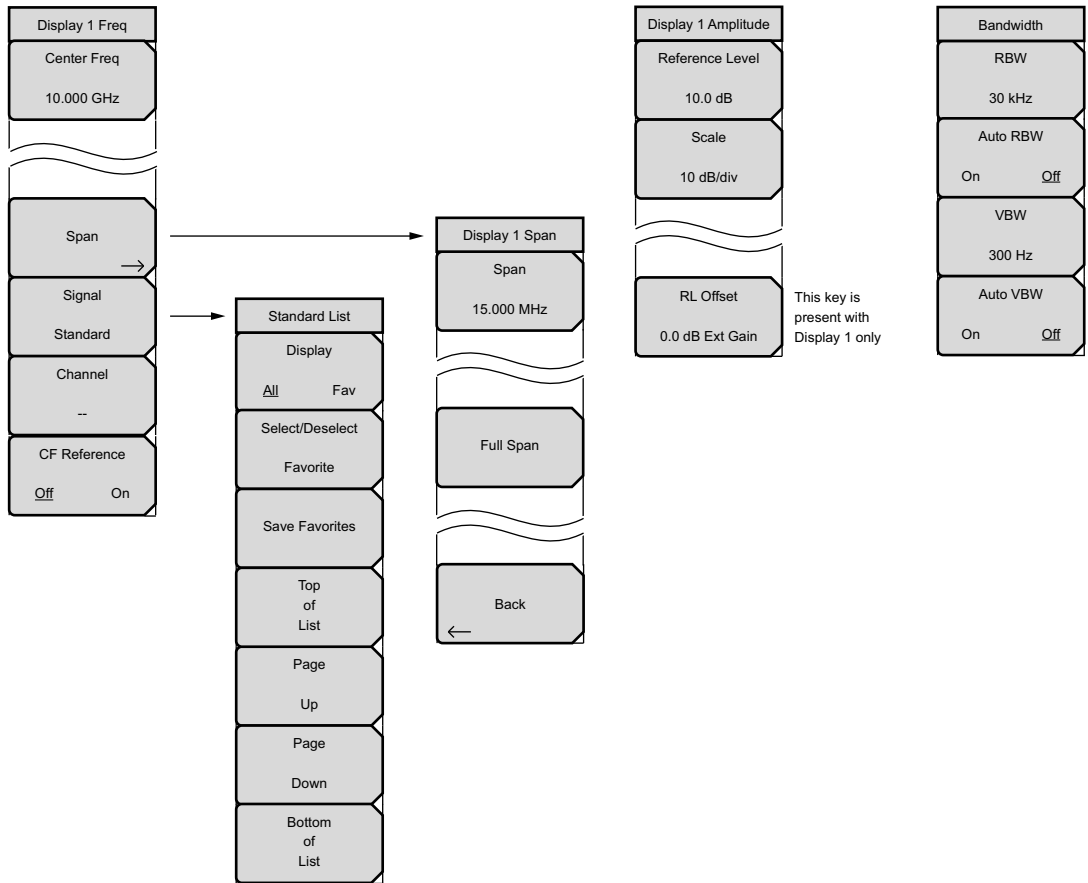


Figure 2-6. Main Menu Map (1 of 2)

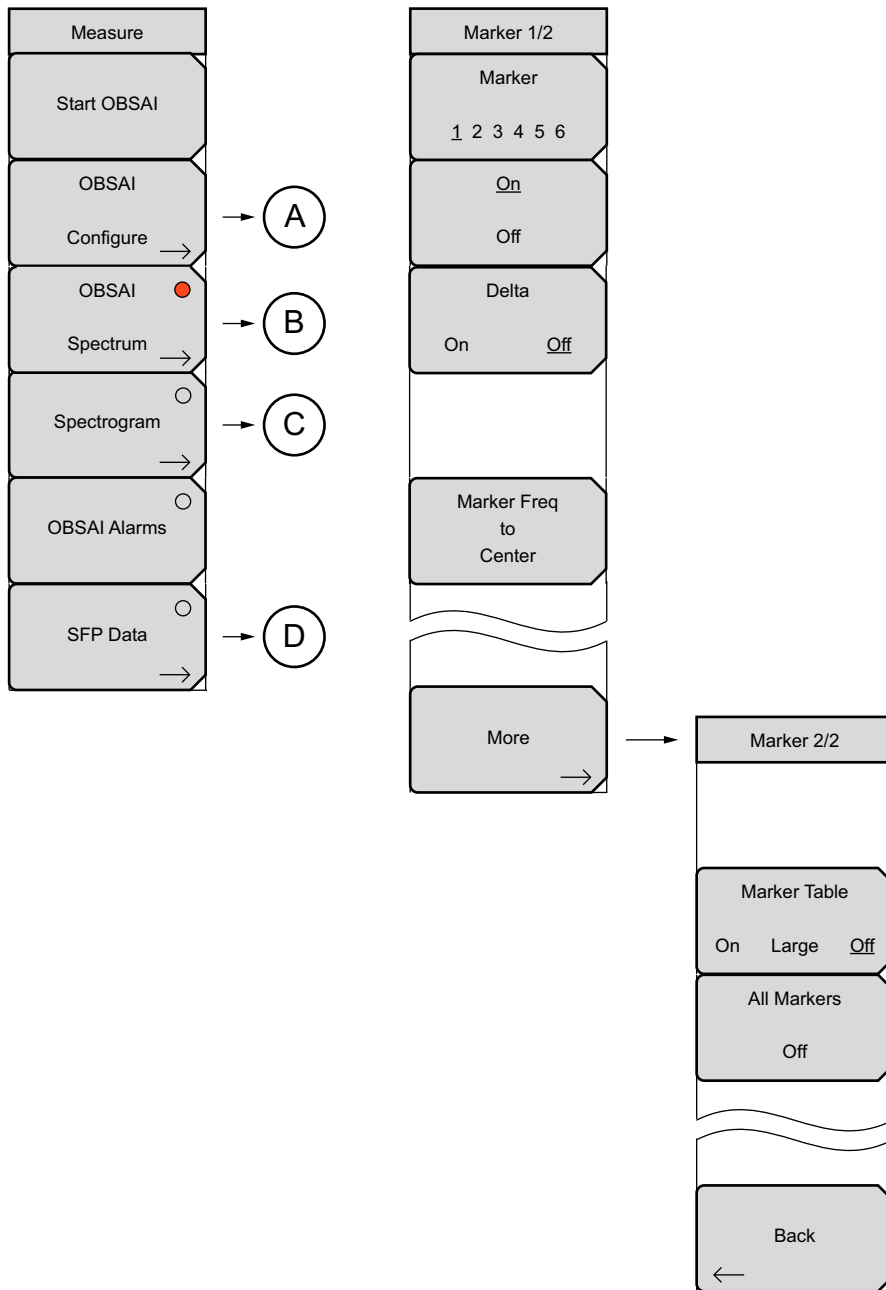


Figure 2-7. Main Menu Map (2 of 2)

Measurements Menu Map

Figure 2-8 and Figure 2-9 show the OBSAI Analyzer Measurements menu and submenus.

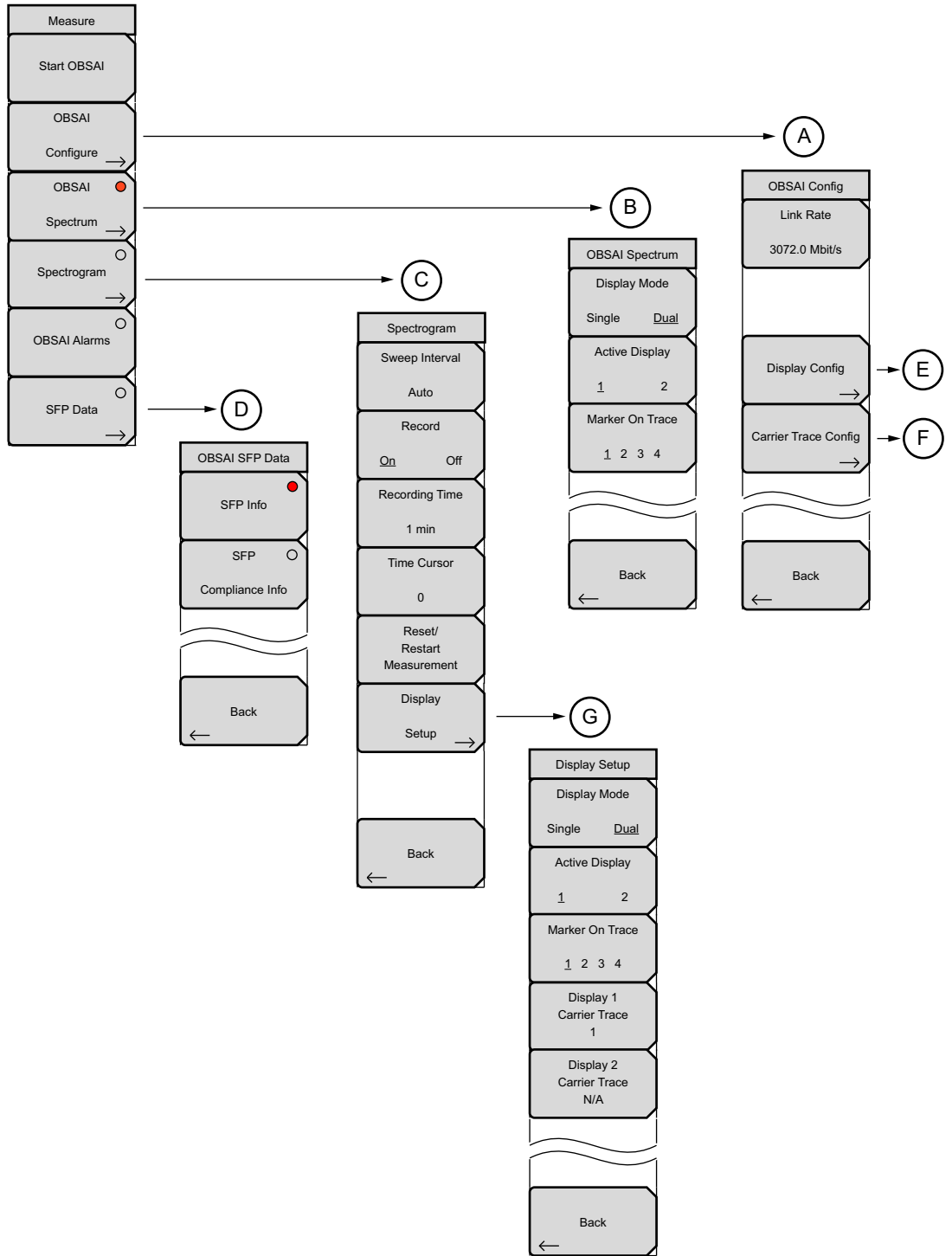


Figure 2-8. Measurements Menu Map (1 of 2)

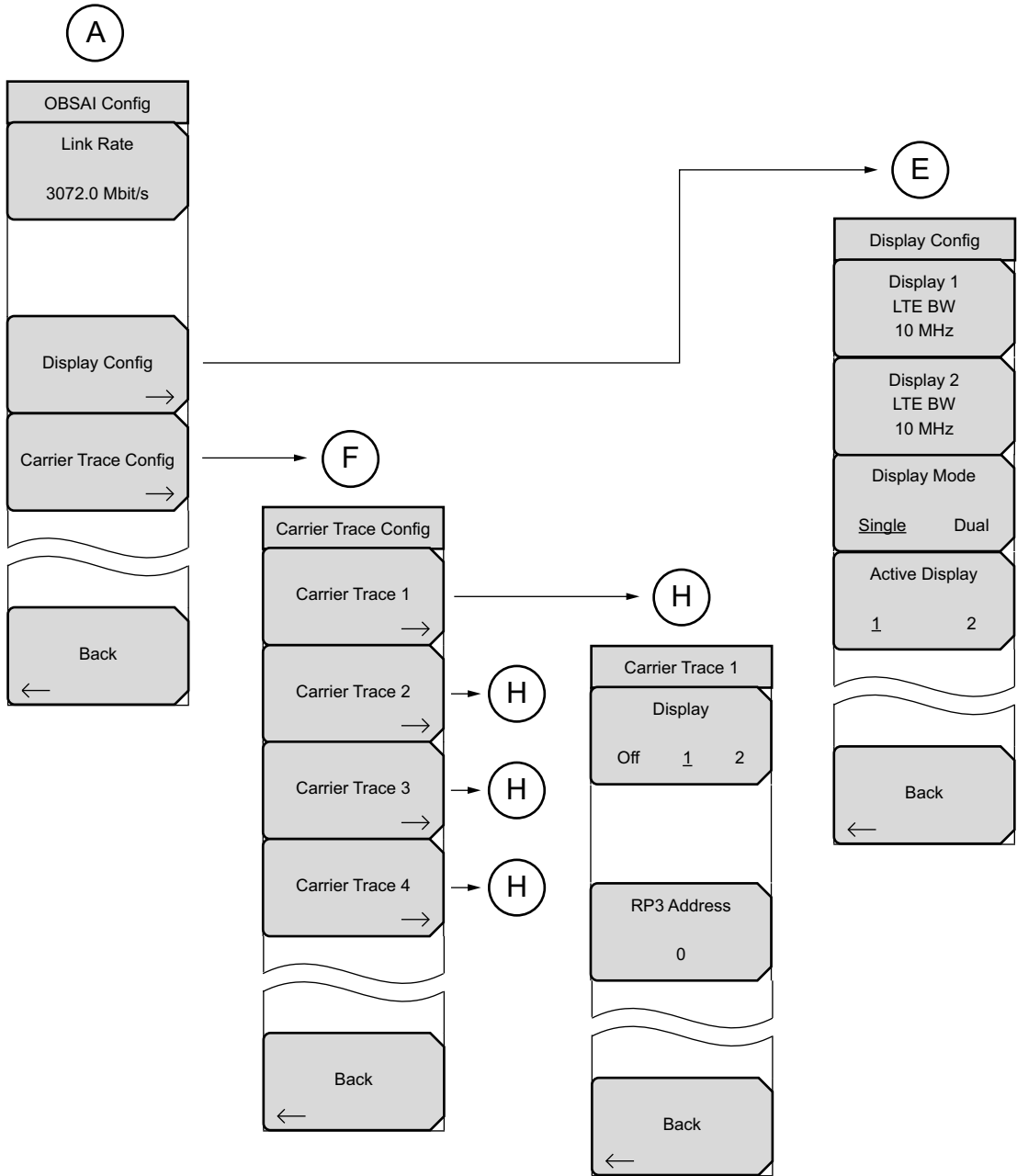


Figure 2-9. Measurements Menu Map (2 of 2)

Sweep Menu

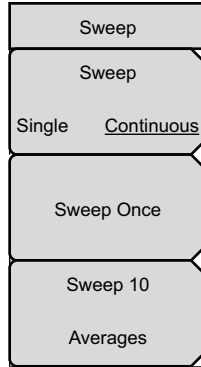


Figure 2-10. Sweep Submenu Keys

Trace Menus

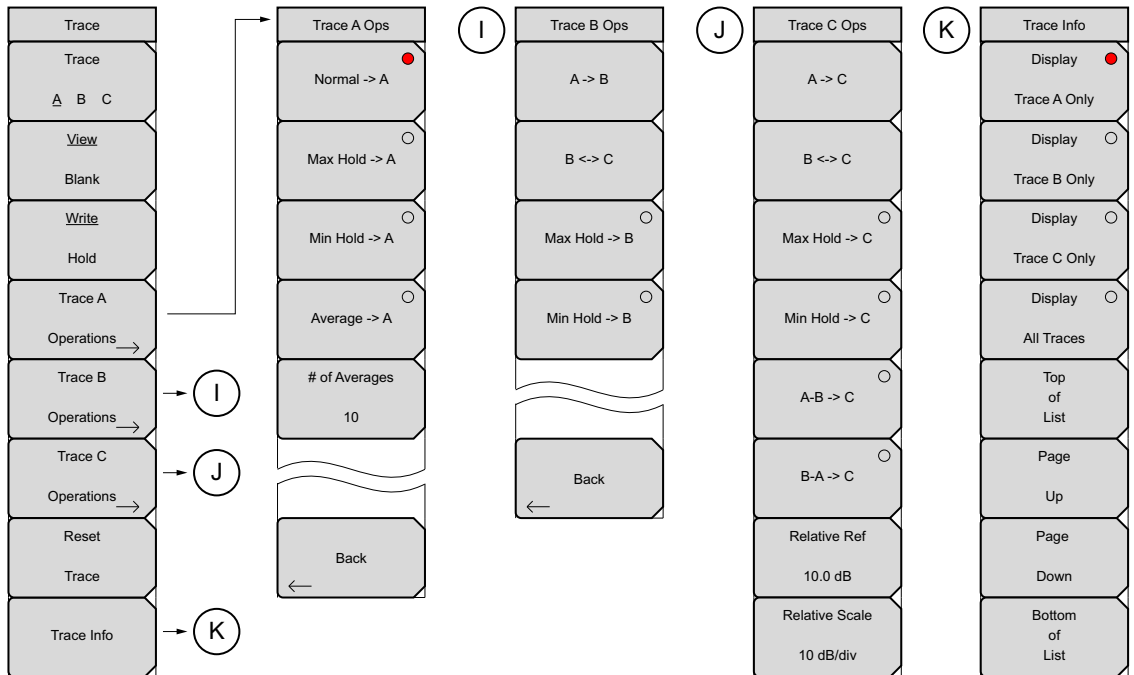


Figure 2-11. Trace Submenu Keys

Limit Menu

The Limit menu is applicable to Spectrum view only. Settings under this menu apply to the currently active display as indicated in the menu title (Display 1 or 2).

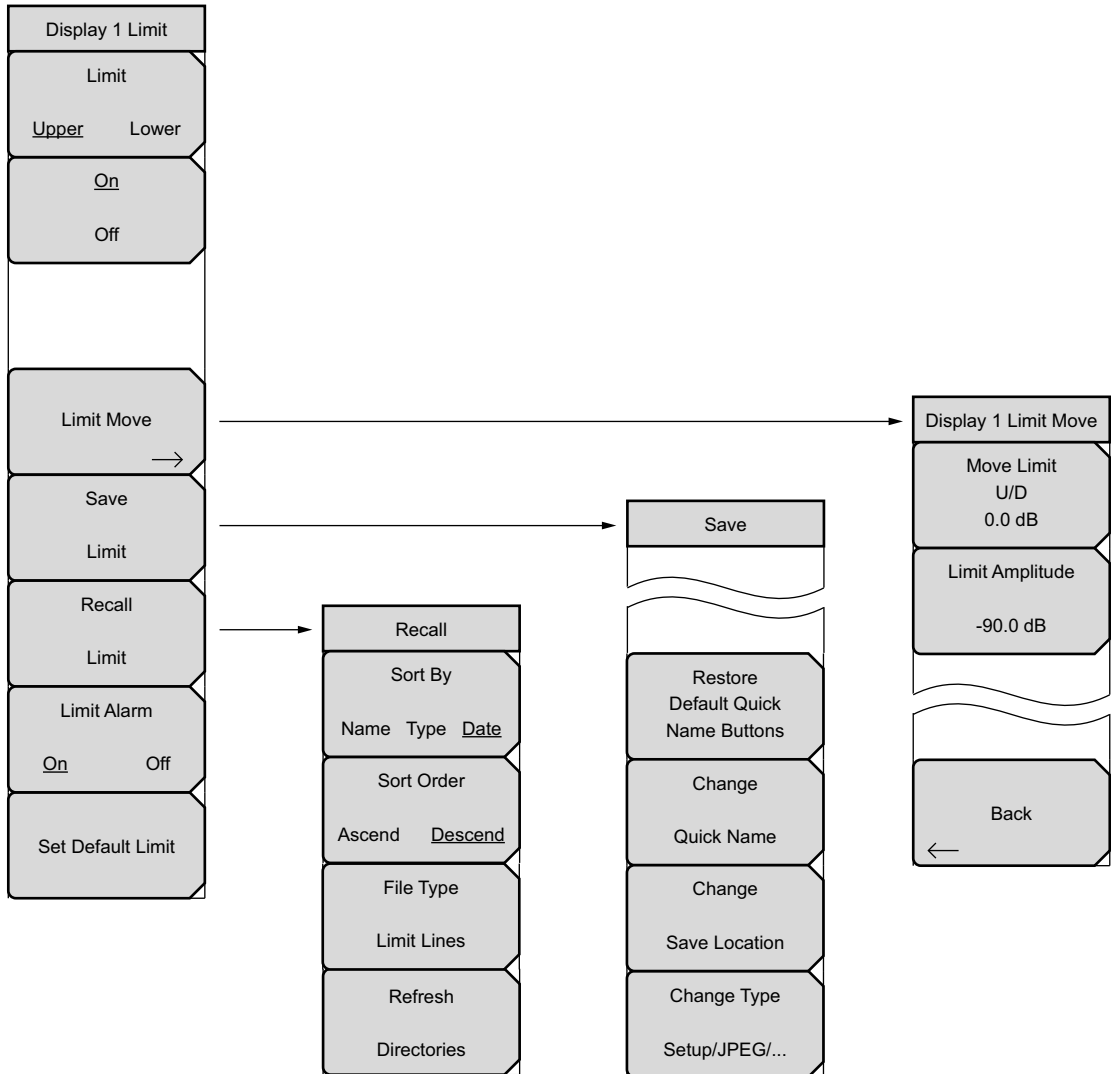


Figure 2-12. Limit Submenu Keys

2-8 Freq Menu

Key Sequence: **Freq**

<div style="border: 1px solid black; padding: 5px; margin-bottom: 5px;"> Display 1 Freq Center Freq 10.000 GHz </div> <div style="border: 1px solid black; padding: 5px; margin-bottom: 5px;"> Span → </div> <div style="border: 1px solid black; padding: 5px; margin-bottom: 5px;"> Signal Standard </div> <div style="border: 1px solid black; padding: 5px; margin-bottom: 5px;"> Channel -- </div> <div style="border: 1px solid black; padding: 5px; margin-bottom: 5px;"> CF Reference Off On </div> <div style="border: 1px solid black; padding: 5px; margin-bottom: 5px;"> Standard List </div> <div style="border: 1px solid black; padding: 5px; margin-bottom: 5px;"> Display All Fav </div> <div style="border: 1px solid black; padding: 5px; margin-bottom: 5px;"> Select/Deselect Favorite </div> <div style="border: 1px solid black; padding: 5px; margin-bottom: 5px;"> Save Favorites </div> <div style="border: 1px solid black; padding: 5px; margin-bottom: 5px;"> Top of List </div> <div style="border: 1px solid black; padding: 5px; margin-bottom: 5px;"> Page Up </div> <div style="border: 1px solid black; padding: 5px; margin-bottom: 5px;"> Page Down </div> <div style="border: 1px solid black; padding: 5px;"> Bottom of List </div>	<p>Settings under the Freq menu apply to the currently active display as indicated in the menu title (Display 1 or 2).</p> <p>Center Freq: Press this key, then enter the desired frequency using the numeric keypad, the arrow keys, or the rotary knob. If entering a frequency with the keypad, the menu key labels will change to GHz, MHz, kHz, and Hz. Press the appropriate Units key. Pressing the Enter key selects MHz as the default frequency unit.</p> <p>To allow the OBSAI signal to move off center (pan), adjust the center frequency to a different value. Depending on the value entered, this may automatically adjust the frequency span, as there cannot be panning without zooming.</p> <p>Span: Press this submenu key to display the “Span Menu” on page 2-18.</p> <p>Signal Standard: Press this key to open the Standard List menu shown on the left and display the Signal Standards list box illustrated in Figure 2-14 and Figure 2-15. You can select a standard from the complete list or from a list of previously saved Favorites. Use the touch screen, arrow keys, or rotary knob to highlight a signal standard, then press Enter to select.</p> <p>To add a standard to a Favorites list, highlight the desired standard in the “Display All” view and press Select/Deselect Favorite. An asterisk (*) appears next to the standard name. Press Save Favorites.</p> <p>To remove a standard from the Favorites list, highlight the item marked with an asterisk in either the All View or the Favorites View and press Select/Deselect Favorite, then press Save Favorites.</p> <p>Channel: After selecting a signal standard, press this key to display the Channel Editor dialog. Enter a valid band. See Figure 2-16 on page 2-17.</p> <p>CF Reference Off/On: Press this submenu key to toggle the center frequency reference setting On or Off. When set to On, you can pan and zoom by adjusting the center frequency and span. This feature is available only when Display 1 is active.</p> <p>Display All/Fav: Press this key to toggle between displaying the complete Standards List or the Favorites List. Items previously saved as favorites are marked with an asterisk (*).</p> <p>Select/Deselect Favorite: Press this key to mark or unmark the currently highlighted standard as a favorite. Any changes you make are not saved until you press Save Favorites or Enter.</p> <p>Save Favorites: Saves the Favorites list with all standards that are marked with an asterisk.</p> <p>Use the navigation keys to quickly scroll through the Standards List.</p>
-------------------------------------------------------------------------------------------------------------------------------------------------------------------------------------------------------------------------------------------------------------------------------------------------------------------------------------------------------------------------------------------------------------------------------------------------------------------------------------------------------------------------------------------------------------------------------------------------------------------------------------------------------------------------------------------------------------------------------------------------------------------------------------------------------------------------------------------------------------------------------------------------------------------------------------------------------------------------------------------------------------------------------------------------------------------------------------------------------------------------------------------------------------------------------------------------------------------------------------------------------------------------------------------------------------------------------------------------------------------------------------------------------------------------------------------------------------------------------------------------------------------------------------------------------------------------------------------------------------------------------------------------------------------------------------------------------------------------------------------------------------------------------------------------------------------------------------------------------------------------------------------------------------------------------------------------------------------------------	---------------------------------------------------------------------------------------------------------------------------------------------------------------------------------------------------------------------------------------------------------------------------------------------------------------------------------------------------------------------------------------------------------------------------------------------------------------------------------------------------------------------------------------------------------------------------------------------------------------------------------------------------------------------------------------------------------------------------------------------------------------------------------------------------------------------------------------------------------------------------------------------------------------------------------------------------------------------------------------------------------------------------------------------------------------------------------------------------------------------------------------------------------------------------------------------------------------------------------------------------------------------------------------------------------------------------------------------------------------------------------------------------------------------------------------------------------------------------------------------------------------------------------------------------------------------------------------------------------------------------------------------------------------------------------------------------------------------------------------------------------------------------------------------------------------------------------------------------------------------------------------------------------------------------------------------------------------------------------------------------------------------------------------------------------------------------------------------------------------------------------------------------------------------------------------------------------------------------------------------------------------------------------------------------------------------------------------------------------------------------------------------------------------------------------------------------------------------------------------------------------------------------------------------------------------------------------------------------------------------------------------------------------------------------------------------------------------------------------------------------------------------

Figure 2-13. Frequency Menu

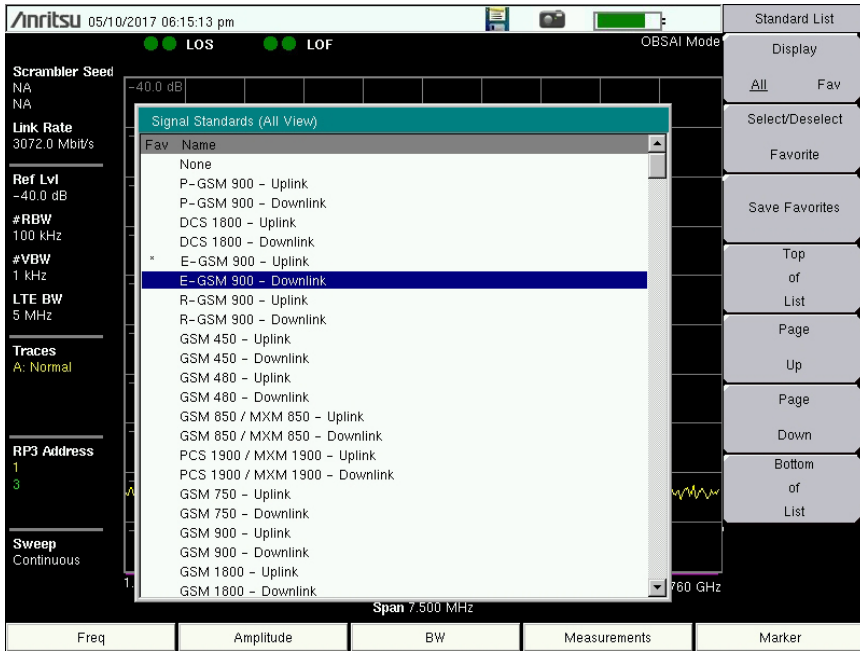


Figure 2-14. Signal Standards List - All View

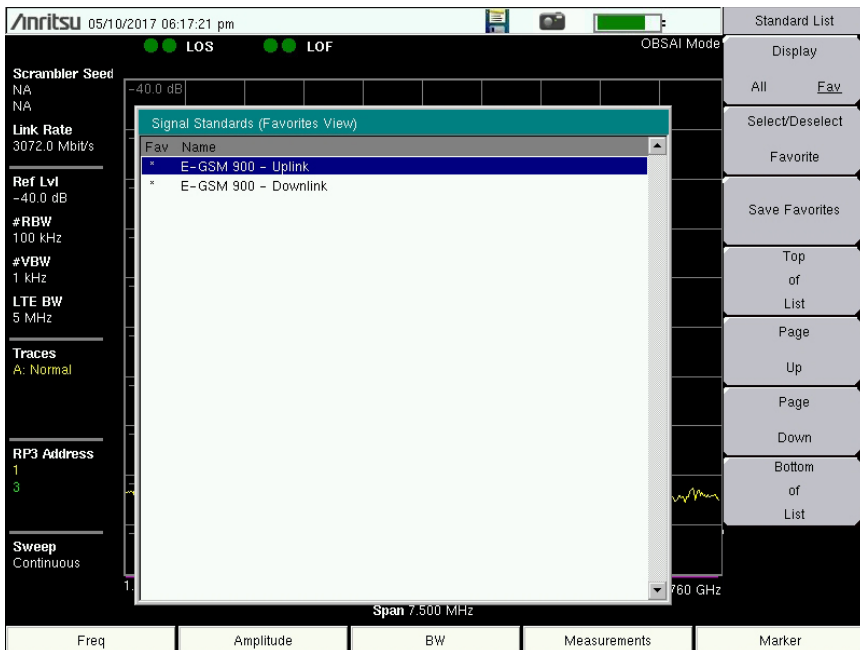


Figure 2-15. Signal Standards List - Favorites View

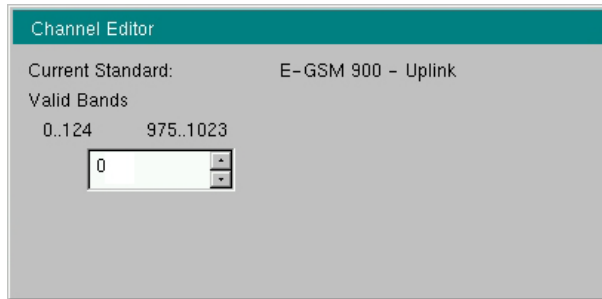
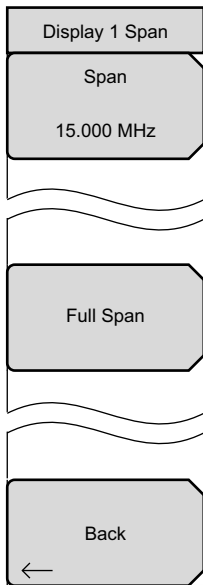


Figure 2-16. Channel Editor Dialog Box

2-9 Span Menu

Key Sequence: **Freq** > Span



Settings under the Span menu apply to the currently active display as indicated in the menu title (Display 1 or 2).

Span: This submenu key shows the current value for span in units of GHz, MHz, kHz, or Hz. When the Span button is pressed, span becomes the active parameter and may be changed. Use the keypad, the directional arrow keys, or the rotary knob to increase or decrease the frequency span. If the span is changed using the arrow keys or rotary knob, the span changes in steps of 0.5 MHz. If entering a span with the keypad, the submenu key labels will change to GHz, MHz, kHz, and Hz. Press the appropriate Units key. Pressing the **Enter** key selects MHz as the default frequency unit.

The maximum span is the LTE bandwidth + 50%. The minimum span is 10 kHz. If you attempt to set a span of less than 10 kHz, the instrument will apply the default minimum span of 10 kHz.

Full Span: Pressing this key sets the span to cover the entire tunable spectrum of the instrument.

Back: Returns to the [“Freq Menu” on page 2-15](#).

Figure 2-17. Span Menu

2-10 Amplitude Menu

Key Sequence: **Amplitude**

<p>Display 1 Amplitude</p>	<p>Settings under the Amplitude menu apply to the currently active display as indicated in the menu title (Display 1 or 2).</p>
<p>Reference Level</p> <p>10.0 dB</p>	<p>Reference Level: The reference level is the top grid line of the sweep window and can be set from +30 dB to -150 dB. Press this key, then use the arrow keys or the rotary knob to change the reference level value.</p>
<p>Scale</p> <p>10 dB/div</p>	<p>To enter a negative value with the numeric keypad, press the +/- key for a minus sign. After entering the value, press the dB submenu key or the Enter key to apply.</p>
<p>The reference level value may be modified by the reference level offset value to compensate for an external attenuator or amplifier.</p>	
<p>RL Offset</p> <p>0.0 dB Ext Gain</p>	<p>Scale: The scale can be set in 1 dB steps from 1 dB per division to 15 dB per division. The value can be changed using the keypad, the rotary knob, or the arrow keys.</p>
<p>RL Offset: RL Offset compensates for the presence of external input attenuation or gain. It applies to Display 1 only, whether the display mode is single or dual. Press this key, then use the arrow keys or the rotary knob to change the offset value. You can also enter a value using the numeric keypad, then select dB External Gain or dB External Loss as appropriate.</p>	

Figure 2-18. Amplitude Menu

2-11 Units of External Gain or Loss

Key Sequence: **Amplitude** > RL Offset > **Keypad** Entry

<p>Units</p>	<p><i>These units are for RL Offset Gain or Loss.</i></p>
<p>dB</p> <p>External Gain</p>	<p>dB External Gain: Enter a value with the numeric keypad, then press this submenu key for external gain. Use the +/- key for a negative value. Note that a negative external gain equates to an external loss.</p>
<p>dB</p> <p>External Loss</p>	<p>dB External Loss: Enter a value with the numeric keypad, then press this submenu key for external loss. Use the +/- key for a negative value. A negative external loss equates to an external gain.</p>
<p>The reference level value may be modified by the reference level offset value to compensate for an external attenuator or amplifier.</p>	
<p>Backspace</p>	<p>Backspace: Press this submenu key to delete the last digit entered.</p>

Figure 2-19. Units Menu for External Gain or Loss

2-12 Bandwidth Menu

Key Sequence: **BW**

Bandwidth	<p>RBW: The current resolution bandwidth value is displayed in this submenu key. The RBW can be changed using the keypad, the arrow keys, or the rotary knob. The value range is 300 Hz to 1 MHz. Available settings are: 300 Hz, 1 kHz, 3 kHz, 10 kHz, 30 kHz, 100 kHz, 300 kHz, and 1 MHz.</p>
RBW 30 kHz	<p>The RBW value changes automatically when the frequency span is changed and Auto RBW is on. In this case, the new RBW value is an approximation selected out of the valid settings listed above, based on a span to resolution bandwidth ratio of 100. Manually changing the resolution bandwidth turns off the Auto RBW setting.</p>
Auto RBW On Off	<p>Auto RBW On/Off: This parameter controls the coupling state of RBW to the frequency span. When Auto RBW is set to on, the instrument adjusts the RBW value automatically based on the current frequency span. The ratio of span to RBW is 100, meaning that the span width is approximately 100 times the resolution bandwidth. The value is approximate because resolution bandwidth filters come in discrete steps while span width can be set to any value up to the maximum span of the instrument. To disassociate RBW from the span, turn off Auto RBW.</p>
VBW 300 Hz	<p>VBW: The current video bandwidth value is displayed in this submenu key. The VBW can be changed using the keypad, arrow keys, or the rotary knob. The value range is 30 Hz to 1 MHz. Available settings are: 30 Hz, 100 Hz, 300 Hz, 1 kHz, 3 kHz, 10 kHz, 30 kHz, 100 kHz, 300 kHz, and 1 MHz.</p>
Auto VBW On Off	<p>The VBW value changes automatically when RBW is changed and Auto VBW is on, in which case VBW is an approximation selected out of the valid frequencies listed above, based on an RBW/VBW. ratio of 3. For example, if RBW is 1 MHz, VBW will be 300 kHz. Manually changing the video bandwidth turns off Auto VBW.</p> <p>Auto VBW On/Off: This parameter sets the coupling state of the video bandwidth to the resolution bandwidth. When Auto VBW is on, the instrument automatically adjusts the VBW value to one third (1/3) the current RBW setting. To disassociate VBW from RBW, turn off Auto VBW.</p>

Figure 2-20. Bandwidth Menu

2-13 Measure Menu

Key Sequence: **Measurements**

or: **Shift > Meas (4)**

Measure	
Start OBSAI	Start OBSAI: Press this key to initiate a scan of the OBSAI links for active RP3 addresses and detect the link rate. When Start OBSAI finds one or more valid RP3 addresses, the display will reset to a single Spectrum graph with Carrier Trace 1 displaying the first available RP3 address in the list. The display bandwidth is set to match the LTE bandwidth of Trace 1.
OBSAI Configure →	To display additional traces (up to four), go to “Carrier Trace Config Menu” on page 2-25 , select the trace number, then choose Display 1 or 2 and select an RP3 address.
OBSAI Spectrum →	The RP3 address list is empty following an instrument power cycle or when no OBSAI carriers are found. You must then plug in a new OBSAI link or run a scan with Start OBSAI to obtain valid address entries.
Spectrogram	OBSAI Configure: Opens the “OBSAI Config Menu” on page 2-23 .
OBSAI Alarms	OBSAI Spectrum: Press this key to select the OBSAI spectrum view. Depending on the current display mode, you may have to press the key a second time to open the “OBSAI Spectrum Menu” on page 2-27 .
SFP Data	Spectrogram: Press this key to select the spectrogram view and open the “Spectrogram Menu” on page 2-28 .
	OBSAI Alarms: Displays the SFP port alarm status and the Tx and Rx optical power levels. See Figure 2-22 on page 2-22 for an example of a dual-SFP display. “Pass” status is shown as green; “Fail” is red. Colors may appear differently depending on the display settings. No color, or grey, means there is no connection at the SFP port.
	SFP Data: Opens the “OBSAI SFP Data Menu” on page 2-31 .

Figure 2-21. Measure Menu

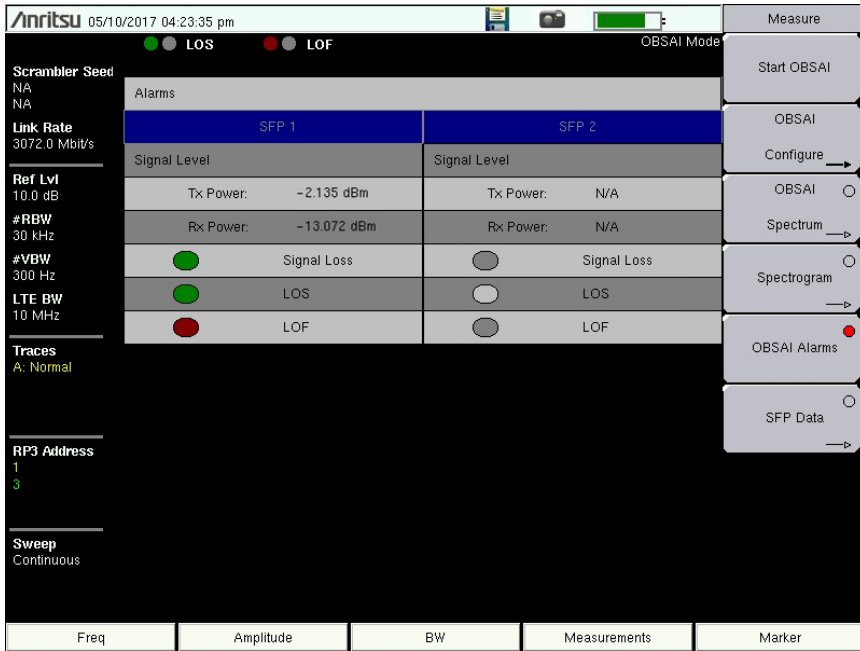


Figure 2-22. OBSAI Alarms Screen (dual-SFP Model Is Shown)

2-14 OBSAI Config Menu

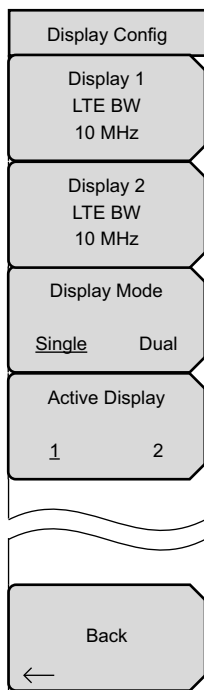
Key Sequence: **Measurements** > OBSAI Configure

OBSAI Config	Link Rate: Press this key to display the Select Link Rate list box.
Link Rate 3072.0 Mbit/s	Link Rate 1x = 768.0 Mbit/s Link Rate 2x = 1536.0 Mbit/s Link Rate 4x = 3072.0 Mbit/s Link Rate 8x = 6144.0 Mbit/s
Display Config →	The link rate is automatically set when valid carriers are detected, following either a Start OBSAI operation or a new fiber plug-in. Dual-SFP instrument models can only detect one link rate for both SFPs.
Carrier Trace Config →	Display Config: Press this key to open the “Display Config Menu” on page 2-24.
Back ←	Carrier Trace Config: Press this key to open the “Carrier Trace Config Menu” on page 2-25.
	Back: Returns to the “Measure Menu” on page 2-21.

Figure 2-23. OBSAI Configure Menu

2-15 Display Config Menu

Key Sequence: **Measurements** > OBSAI Configure > Display Config



Display 1 LTE BW: This is the LTE carrier bandwidth for Display 1. Press this key to display the Select Bandwidth list box illustrated in [Figure 2-25](#). Use the touch screen, arrow keys, or rotary knob to highlight the LTE carrier bandwidth, then press **Enter**. Selectable values are 5 MHz, 10 MHz, 15 MHz, and 20 MHz.

If the bandwidth (such as 10 MHz) is displayed in red on the menu key label, you can use the arrow keys or rotary knob to change the value, then press **Enter**.

Display 2 LTE BW: This key is active only in dual display mode. Press the key to open the Select Bandwidth list box illustrated in [Figure 2-25](#). Use the touch screen, arrow keys, or rotary knob to highlight the LTE carrier bandwidth for Display 2, then press **Enter**. Selectable values are 5 MHz, 10 MHz, 15 MHz, and 20 MHz.

Display Mode

Single Dual: Press this key to toggle between single and dual display mode. Up to four traces can be displayed on a single display, or they may be distributed between the two displays in dual display mode, as illustrated in [Figure 2-30 on page 2-27](#).

When switching from dual to single mode, the currently active display, as selected by the Active Display key described below, will be shown as the single display.

Active Display

1 2: This key is active only in dual display mode. Press the key to toggle between Display 1 and 2. The currently active display is highlighted with a red border. See [Figure 2-30 on page 2-27](#). Settings under the following menus apply to the active display only:

- Frequency
- Amplitude
- Bandwidth
- Limit

Back: Returns to the [“OBSAI Config Menu” on page 2-23](#).

Figure 2-24. Display Config Menu



Figure 2-25. Select LTE Bandwidth

2-16 Carrier Trace Config Menu

Key Sequence: **Measurements** > OBSAI Configure > Carrier Trace Config

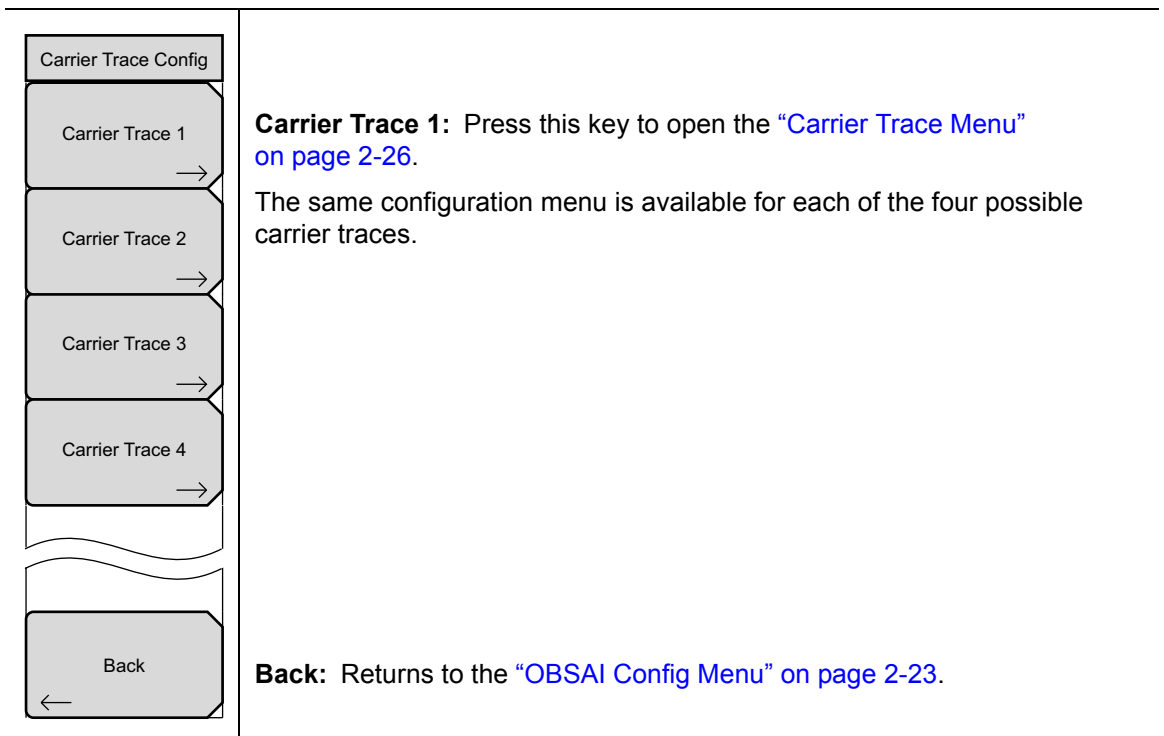
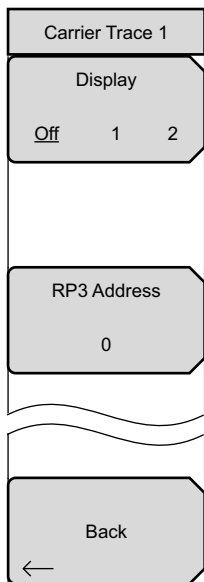


Figure 2-26. Carrier Trace Config Menu

2-17 Carrier Trace Menu

Key Sequence: **Measurements** > OBSAI Configure > Carrier Trace Config > Carrier Trace 1



Each of the four possible carrier traces has its own configuration menu.

Display: Press this key to select which display, 1 or 2, will show the current trace. Off turns off the trace.

RP3 Address: Press this key to display the most recent list of active RP3 addresses. [Figure 2-28](#) shows an example. Use the touch screen, rotary knob, or arrow keys to highlight an address in the list, then press **Enter** to select.

If the LTE bandwidth associated with the selected RP3 address does not match that of the currently active display (1 or 2), a warning message appears, stating that the display's LTE bandwidth will be changed to match the RP3 bandwidth. Press OK or **Enter** to proceed.

If you press RP3 Address and the list is currently empty, a message will display, prompting you to press Start OBSAI under the Measurements menu to obtain valid address entries. Alternatively, the instrument will automatically detect available RP3 addresses when a valid OBSAI link is plugged in.

Back: Returns to the ["Carrier Trace Config Menu"](#).

Figure 2-27. Carrier Trace Menu

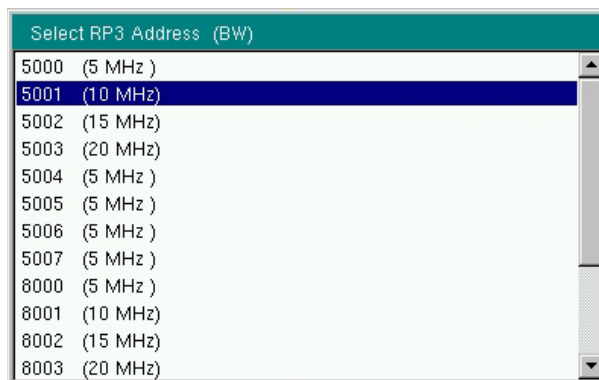


Figure 2-28. Select RP3 Address

2-18 OBSAI Spectrum Menu

Key Sequence: **Measurements** > OBSAI Spectrum

If the previously selected measurement display mode was Spectrogram, press the OBSAI Spectrum key a second time to display the menu below.

<div style="border: 1px solid black; padding: 5px; margin-bottom: 5px;">OBSAI Spectrum</div> <div style="border: 1px solid black; padding: 5px; margin-bottom: 5px;">Display Mode Single <u>Dual</u></div> <div style="border: 1px solid black; padding: 5px; margin-bottom: 5px;">Active Display 1 2</div> <div style="border: 1px solid black; padding: 5px; margin-bottom: 5px;">Marker On Trace 1 2 3 4</div> <div style="border: 1px solid black; padding: 5px; margin-bottom: 5px;">Back ←</div>	<p>Display Mode Single Dual: Press this key to toggle between single and dual display mode. Up to four traces can be displayed on a single display, or they may be distributed between the two displays in dual display mode, as illustrated in Figure 2-30.</p> <p>When switching from dual to single mode, the currently active display, as selected by the Active Display key described below, will be shown as the single display.</p> <p>Active Display 1 2: This key is active only in dual display mode. Press the key to toggle between Display 1 and 2. The currently active display is highlighted with a red border. See Figure 2-30. Settings under the following menu apply to the active display only: Frequency, Amplitude, Bandwidth, Limit.</p> <p>Marker On Trace 1 2 3 4: Press this key to select the carrier trace to which markers are applied. Markers are activated on one trace at a time.</p> <p>Back: Returns to the “Measure Menu” on page 2-21.</p>
----------------------------------------------------------------------------------------------------------------------------------------------------------------------------------------------------------------------------------------------------------------------------------------------------------------------------------------------------------------------------------------------------------------------------------------------------------------------------------------------------------------------------------	--------------------------------------------------------------------------------------------------------------------------------------------------------------------------------------------------------------------------------------------------------------------------------------------------------------------------------------------------------------------------------------------------------------------------------------------------------------------------------------------------------------------------------------------------------------------------------------------------------------------------------------------------------------------------------------------------------------------------------------------------------------------------------------------------------------------------------------------------------------------------------------------------------------------------------------------------------------------------------------------------------------------------------------------------------------------------------------------------

Figure 2-29. OBSAI Spectrum Menu

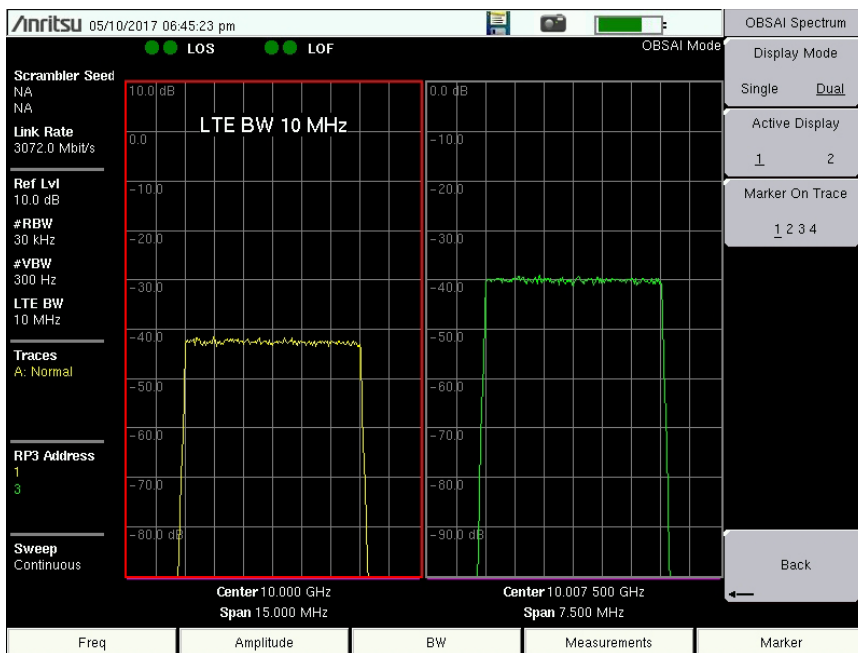


Figure 2-30. Spectrum Dual Display

2-19 Spectrogram Menu

Key Sequence: **Measurements** > Spectrogram

Spectrogram	Sweep Interval: Press this key, then use the numeric keypad, the arrow keys, or the rotary knob to set the sweep interval in min, s, ms, or μ s. The Auto setting is equivalent to a zero value. The currently active trace must be set to Max Hold, Min Hold, or Average for the sweep interval to have an effect.
Sweep Interval Auto	Record On Off: Press this key to start (On) or cancel (Off) recording. When turning on recording, measurement data is recorded for the specified Recording Time, then saved in internal memory in a date and time labeled folder. The file name is of the form <code>OBSAI_SPGYyyyymmddhhmmss.obsai</code> .
Record On Off	The Record setting automatically turns off at the end of the timed measurement.
Recording Time 1 min	Recording Time: Sets the recording time in units of hour, min, s, ms, or μ s. One minute is the minimum time setting, and it is the default setting when Record is set to on. This key is displayed only when Record is set to on.
Time Cursor 0	Time Cursor: Press this key, then use the numeric keypad, the arrow keys, or the rotary knob to set the time cursor value. This setting enables time tracking for the intermittent interference signals. The current measurement is stopped when the time cursor value is not zero.
Reset/ Restart Measurement	Reset/Restart Measurement: Clears the display and restarts the measurement.
Display Setup →	Display Setup: Opens the “Display Setup Menu” on page 2-29.
Back ←	Back: Returns to the “Measure Menu” on page 2-21.

Figure 2-31. Spectrogram Menu

2-20 Display Setup Menu

Key Sequence: **Measurements** > Spectrogram > Display Setup

Display Setup	Display Mode
Display Mode Single Dual	Single Dual: Press this key to toggle between single and dual display mode. In spectrogram view, only one trace at a time can be displayed as a waterfall measurement, one on each display in dual mode, as illustrated in Figure 2-34 on page 2-30 .
Active Display 1 2	When switching from dual to single mode, the currently active display, as selected by the Active Display key described below, will be shown as the single display.
Marker On Trace 1 2 3 4	Active Display
Display 1 Carrier Trace 1	1 2: This key is active only in dual display mode. Press the key to toggle between Display 1 and 2. The currently active display is highlighted with a red border. Settings under the following menus apply to the active display only:
Display 2 Carrier Trace N/A	Frequency Amplitude Bandwidth Limit
(Wavy line separator)	Marker On Trace
(Wavy line separator)	1 2 3 4: Press this key to select the carrier trace to which markers are applied. Markers are activated on one trace at a time.
Back ←	Display 1 Carrier Trace: Press this key to open the Select Trace list box illustrated in Figure 2-33 . Use the touch screen, rotary knob or arrow keys to highlight a trace number in the list, then press Enter . The selected carrier trace will be the one displayed on Spectrogram Display 1 and the trace number is shown on the key label.
	If no trace has been configured for Display 1, the Display 1 Carrier Trace key label displays N/A in place of the trace number and the Select Trace list box will show “No Carrier Trace Configured.”
	Display 2 Carrier Trace: This key is active only in dual display mode. Press the key to open the Select Trace list box illustrated in Figure 2-33 . Use the touch screen, rotary knob or arrow keys to highlight a trace number in the list, then press Enter . The selected carrier trace will be the one displayed on Spectrogram Display 2 and the trace number is shown on the key label.
	If no trace has been configured for Display 2, the Display 2 Carrier Trace key label displays N/A in place of the trace number and the Select Trace list box will show “No Carrier Trace Configured.”
	In Figure 2-34 , the Carrier Trace information on the left of the instrument screen indicates Display 1 is showing Trace 1, Display 2 is showing Trace 2.
	Back: Returns to the “ Spectrogram Menu ” on page 2-28.

Figure 2-32. Spectrogram Display Setup Menu

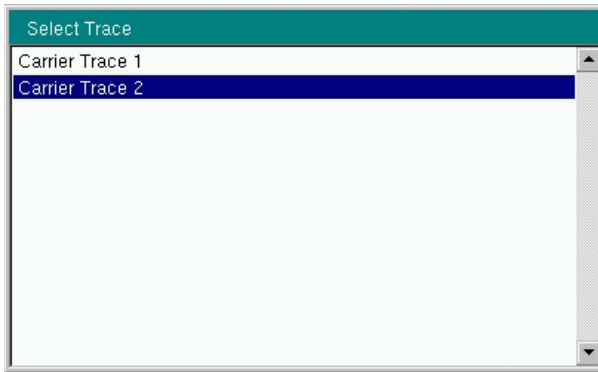


Figure 2-33. Select Trace List Box

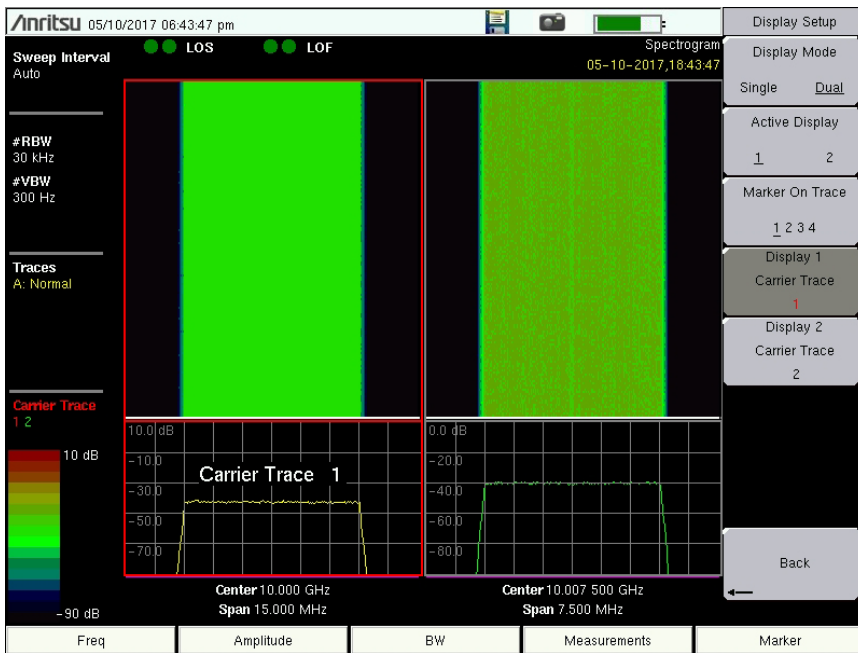


Figure 2-34. Spectrogram Dual Display

2-21 OBSAI SFP Data Menu

Key Sequence: **Measurements** > SFP Data

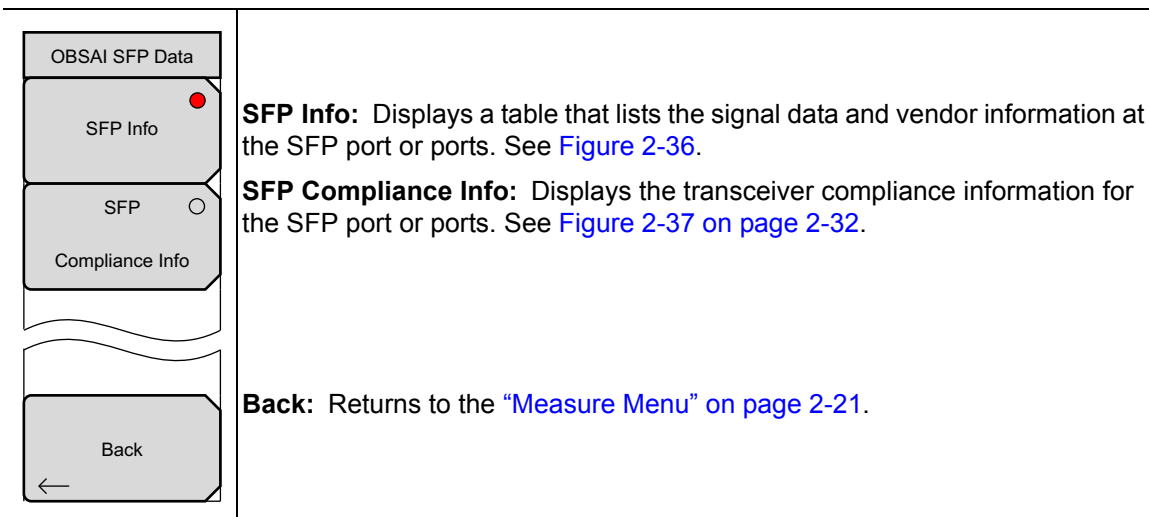


Figure 2-35. OBSAI SFP Data Menu

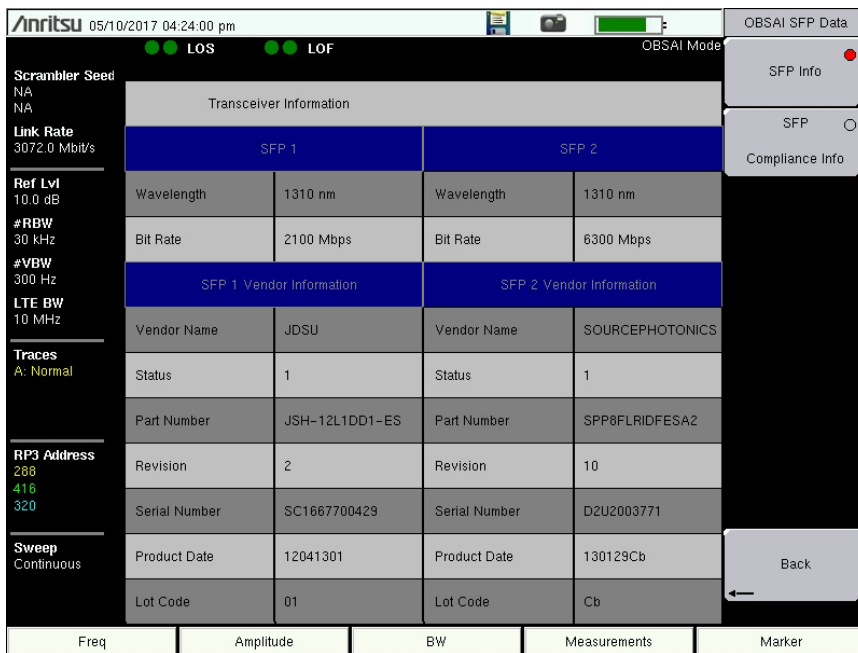


Figure 2-36. SFP Info Screen (Dual-Port Model)

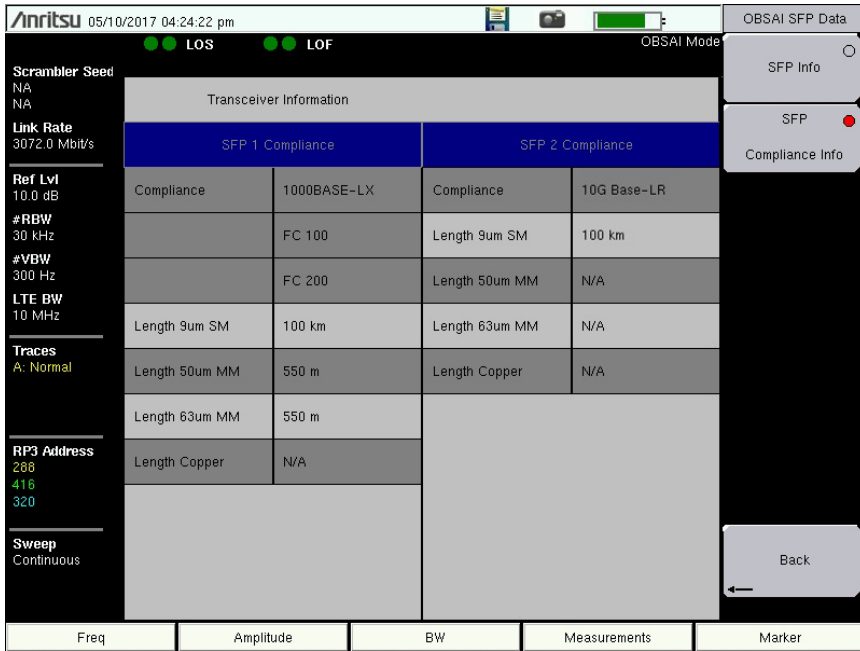


Figure 2-37. SFP Compliance Info Screen (Dual-Port Model)

2-22 Marker Menu

Marker settings apply to the currently selected carrier trace. Press the **Marker** main menu key to open the Marker 1/2 menu. Up to 6 markers may be set, but only on one trace at a time. Use the arrow keys to change marker frequency.

Key Sequence: **Marker**

Marker 1/2	<p>Marker: Press this key to display the Select Marker box illustrated in Figure 2-39, then press a marker number (M1 to M6) to make the marker active and turn it on. The selected marker number is underlined on the Marker menu key.</p> <p>On/Off: Turns on or off the currently active marker. When on, the active marker is highlighted in red. See Figure 2-40 on page 2-34.</p> <p>Delta On/Off: Turns on a delta marker. Use the numeric keypad to enter an offset value from the frequency of the currently active marker. Press the +/- key to enter a negative offset. In Figure 2-41 on page 2-34, the delta marker is set at 2.25 MHz from Marker 2.</p> <p>Marker Freq to Center: Moves the frequency noted by the active marker to the center frequency position and center of the display.</p> <p>More: Opens a submenu of additional Marker options. See the “Marker 2/2 Menu” on page 2-35.</p>
Marker <u>1</u> 2 3 4 5 6	
<u>On</u> Off	
Delta On <u>Off</u>	
Marker Freq to Center	
More →	

Figure 2-38. Marker 1/2 Menu

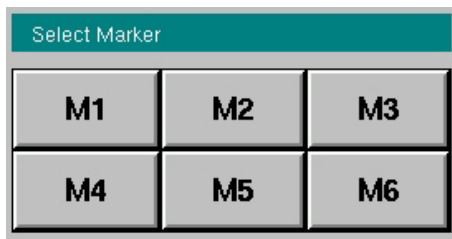


Figure 2-39. Select Marker

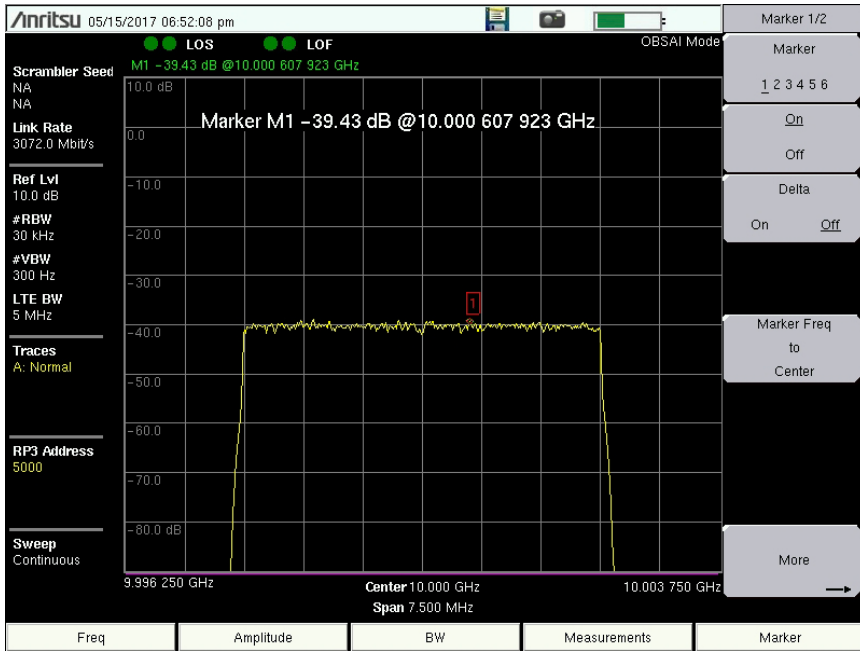


Figure 2-40. Active Marker M1

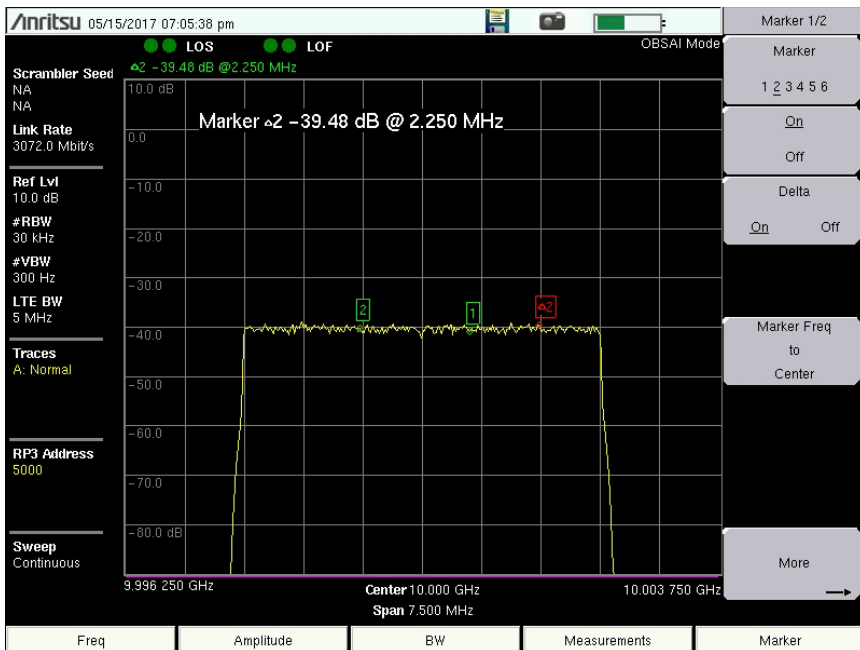


Figure 2-41. Delta Marker 2

2-23 Marker 2/2 Menu

Key Sequence: **Marker** > More

Marker 2/2	<p>Marker Table On Large Off: Press this key to enable or disable the marker table. When set to On, a table showing the frequency and amplitude levels for each marker is displayed below the sweep window. The table is automatically sized to list all markers that are turned on. If Large is selected, the currently active marker's amplitude and frequency will be displayed in large type below the sweep window. See Figure 2-43.</p> <p>All Markers Off: Turns off all markers.</p> <p>Back: Returns to the "Marker Menu" on page 2-33.</p>
Marker Table On Large <u>Off</u>	
All Markers Off	
Back ←	
Back ←	

Figure 2-42. Marker 2/2 Menu

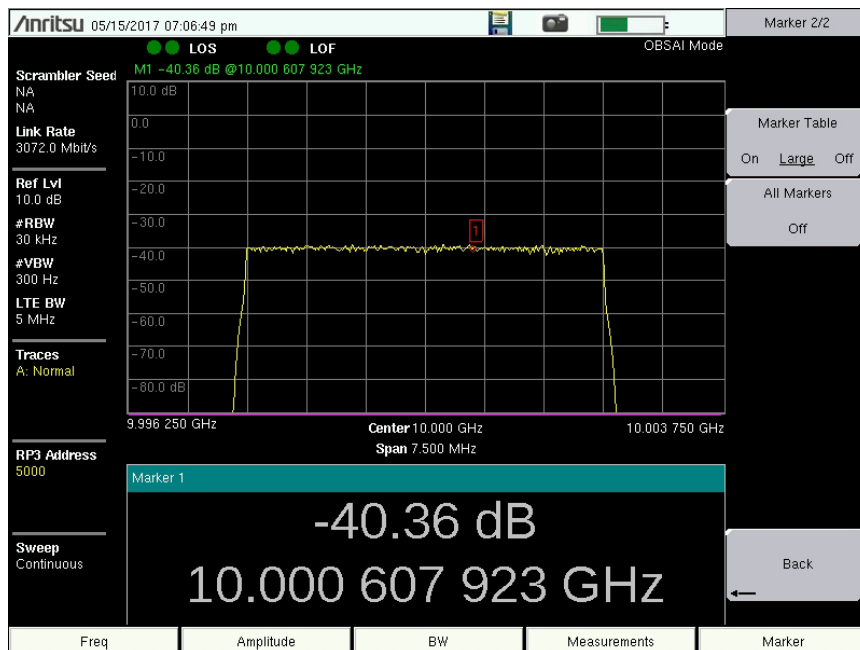
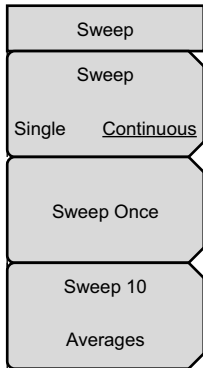


Figure 2-43. Marker Table - Large

2-24 Sweep Menu

Key Sequence: **Shift > Sweep (3)**



Sweep Single/Continuous: This submenu key toggles between continuous sweep and single sweep. In single sweep mode, the results of a sweep are displayed on the screen while the instrument awaits a trigger event to start a new sweep.

Sweep Once: When Sweep is set to Single, Sweep Once triggers a single measurement sweep. This key has no function when the instrument is in continuous sweep mode.

Sweep # Averages: Sweeps the number of times set using the # of Averages button under the Trace A Ops menu. Trace A must be set to Averaging (**Shift > Trace (5)** key > Trace A Operations > Average->A) for this menu to function. Each trace is displayed using the exponential average of each sweep.

Figure 2-44. Sweep Menu

2-25 Trace Menu

The instrument is capable of displaying up to three traces, one with live data, and the other two either with stored data or trace math data. These settings apply only to Carrier Trace 1.

Key Sequence: **Shift > Trace (5)**

Trace	Trace
Trace	A B C: Sets trace A, B, or C as the active trace. Each press of this key increments through trace A, B, and C. The active trace is underlined.
<u>A</u> B C	View/Blank: Displays or hides the active trace.
<u>View</u>	Write/Hold: Selects between holding the current swept trace on the screen or continually sweeping and updating the displayed measurement. This is not applicable to Trace B or Trace C unless trace math involving Trace A is active.
Blank	Trace A Operations: Lists the Trace A Ops menu to select an operation that can be applied to Trace A. See "Trace A Ops Menu" on page 2-38 .
<u>Write</u>	Trace B Operations: Lists the Trace B Ops menu to select an operation that can be applied to Trace B. See "Trace B Ops Menu" on page 2-39 .
Hold	Trace C Operations: Lists the Trace C Ops menu to select an operation that can be applied to Trace C. See "Trace C Ops Menu" on page 2-40 .
Trace A	Reset Trace: Resets the trace averaging, Max Hold or Min Hold, and restarts the sweep.
Operations →	Trace Info: Stops the current trace and displays a summary table of trace parameters and current settings. See Figure 2-46 . Press Enter or Esc to clear the table from the display and restart the trace.
Trace B	Display: Press the appropriate key to display trace information for Trace A Only, Trace B Only, Trace C Only, or All Traces.
Operations →	Top of List: Press this key to jump to the top of the Trace Info table.
Trace C	Page Up: Press this key to skip up through the table.
Operations →	Page Down: Press this key to skip down through the table.
Reset	Bottom of List: Press this key to jump to the bottom of the table.
Trace	
Trace Info	

Figure 2-45. Trace Menu

Trace Info			
Setting	Trace A	Trace B	Trace C
Trace Mode	Normal	Trace Hold	Trace Hold
Center Freq	10.000 GHz	10.000 GHz	10.000 GHz
Current Channel	--	0	0
Span	15.000 MHz	15.000 MHz	15.000 MHz
Start Freq	9.992 500 GHz	9.992 500 GHz	9.992 500 GHz
Stop Freq	10.007 500 GHz	10.007 500 GHz	10.007 500 GHz
Ref Lvl	10.0 dB	10.0 dB	10.0 dB
Detection	Peak		
#RBW	30 kHz	30 kHz	30 kHz
#VBW	300 Hz	300 Hz	300 Hz
VBW/Avg Type	Linear		

Figure 2-46. Trace Info Message Box

2-26 Trace A Ops Menu

Key Sequence: **Shift > Trace (5) > Trace A Operations**

Trace A Ops	
Normal -> A <input checked="" type="radio"/>	Normal -> A: Displays data for the current trace sweep.
Max Hold -> A <input type="radio"/>	Max Hold -> A: Shows the cumulative maximum value of each display point over many trace sweeps.
Min Hold -> A <input type="radio"/>	Min Hold -> A: Shows the cumulative minimum value of each display point over many trace sweeps.
Average -> A <input type="radio"/>	Average -> A: Shows an exponential average of a number of traces, determined by the # of Averages key.
# of Averages 10	# of Averages: Sets the number of traces for use in calculating the average display value. The number used for averaging ranges from 1 to 65535.
~	
Back ←	Back: Returns to the "Trace Menu" on page 2-37 .

Figure 2-47. Trace A Ops Menu

2-27 Trace B Ops Menu

Key Sequence: **Shift** > **Trace (5)** > Trace B Operations

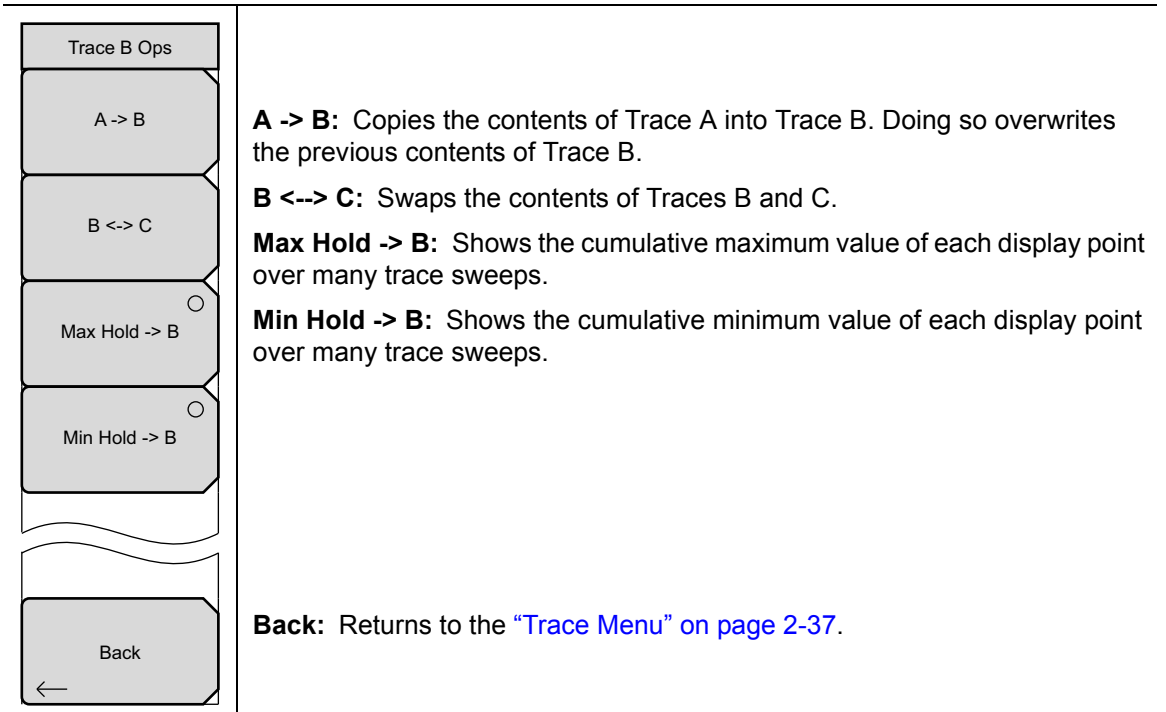


Figure 2-48. Trace B Ops Menu

2-28 Trace C Ops Menu

Key Sequence: **Shift > Trace (5) > Trace C Operations**

Trace C Ops	A -> C: Copies the contents of Trace A into Trace C. Doing so overwrites the previous contents of Trace C.
A -> C	B <-> C: Swaps the contents of Trace B and Trace C.
B <-> C	Max Hold -> C: Shows the cumulative maximum value of each display point over many trace sweeps.
Max Hold -> C	Min Hold -> C: Shows the cumulative minimum value of each display point over many trace sweeps.
Min Hold -> C	A - B -> C: Subtracts the value of Trace B from Trace A and places the results in Trace C. This function is very useful for observing the changes in values of live Trace A compared to a trace stored in Trace B.
A-B -> C	When trace math is active, a relative scale shows on the right side of the graph, and is associated to Trace C. This allows the user to optimize the display of Trace C without affecting the display of Trace A and Trace B.
B-A -> C	B - A -> C: Subtracts the value of Trace A from Trace B and places the results in Trace C. This function is very useful for observing the changes in values of live Trace A compared to a trace stored in Trace B. When trace math is active, a relative scale shows on the right side of the graph, and is associated to Trace C. This allows the user to optimize the display of Trace C without affecting the display of Trace A and Trace B.
Relative Ref	Relative Ref: Sets the value applied to the top graticule for the relative scale that appears on the right side of the graph when trace math is active. Change this value by using the rotary knob, up or down arrows, or entering the value on the numeric keypad and pressing the dB submenu key or the Enter key. This entry is valid only when trace math is active.
10.0 dB	Relative Scale: Sets the value applied to the scaling of the relative scale that appears on the right side of the graph when trace math is active. Change this value by using the rotary knob, up or down arrows, or entering the value on the numeric keypad and pressing the dB submenu key or the Enter key. This entry is valid only when trace math is active.
Relative Scale	Back: Returns to the "Trace Menu" on page 2-37 .
10 dB/div	

Figure 2-49. Trace C Ops Menu

2-29 Limit Menu

In Spectrum view, limit lines may be used for visual reference only or as pass/fail criteria in triggering a limit alarm. You can configure an upper and a lower limit. Each limit is a flat (non-segmented) line that can trigger an alarm whenever any signal data point exceeds the set amplitude limit, when the Limit Alarm setting is set to on.

In dual display mode, the limit settings apply to the currently active display, Display 1 or 2, as denoted in the Limit menu heading. See [Figure 2-50](#).

Key Sequence: **Shift > Limit (6)**

Display 1 Limit	
Limit	Limit
Upper Lower	Upper Lower: Press this key to toggle between configuring either the upper or the lower limit (that is, make it active).
On	On/Off: Turns on or off the active limit line (upper or lower). See Figure 2-52 on page 2-42.
Off	
Limit Move	Limit Move: Opens the “Limit Move Menu” on page 2-42.
Save	Save Limit: Opens the “Save Menu” on page 2-43 and displays a dialog to save the currently active limit line. You can enter a name for the saved limit line or apply the name suggested by the instrument (which is based on a previously saved name). Press Esc to cancel the save operation.
Limit	
Recall	Recall Limit: Opens the “Recall Menu” on page 2-47 and displays a dialog to recall a saved limit line. In the Recall dialog box, navigate to a previously saved limit line file and press Enter to recall. Press Esc to cancel.
Limit	
Limit Alarm	Limit Alarm
On Off	On Off: Press this key to turn on and off the alarm function for the currently active limit line. When on, an alarm beep will sound when any data point exceeds the limit.
Set Default Limit	Set Default Limit: Turns on the currently active limit line and places it at its default position in the sweep window. For the upper limit line, this is two and a half divisions below the top of the grid (or amplitude reference level). The lower limit line default position is two and a half divisions above the bottom of the sweep window.

Figure 2-50. Limit Menu

2-30 Limit Move Menu

Key Sequence: **Shift > Limit (6) > Limit Move**

<div style="border: 1px solid black; padding: 5px; margin-bottom: 5px;">Display 1 Limit Move</div> <div style="border: 1px solid black; padding: 5px; margin-bottom: 5px;">Move Limit U/D 0.0 dB</div> <div style="border: 1px solid black; padding: 5px; margin-bottom: 5px;">Limit Amplitude -90.0 dB</div> <div style="border: 1px solid black; padding: 5px; margin-bottom: 5px;">Back</div>	<p>Move Limit U/D: Press this key and use the rotary knob to adjust the limit amplitude up or down. Use the numeric keypad to enter the distance by which to move the limit, either up or down, from its current amplitude. For example, entering -5 dB will move the current limit line downward 5 dB from its current amplitude.</p> <p>Limit Amplitude: Press this key and set the amplitude of the currently active limit line using the rotary knob or numeric keypad. If using the keypad, press the +/- key for a negative value and press the dB key or Enter to set.</p> <p>Back: Returns to the “Limit Menu” on page 2-41.</p>
--------------------------------------------------------------------------------------------------------------------------------------------------------------------------------------------------------------------------------------------------------------------------------------------------------------------------------------------------------------------------------------------------------------	----------------------------------------------------------------------------------------------------------------------------------------------------------------------------------------------------------------------------------------------------------------------------------------------------------------------------------------------------------------------------------------------------------------------------------------------------------------------------------------------------------------------------------------------------------------------------------------------------------------------------------------------------------------------

Figure 2-51. Limit Move Menu

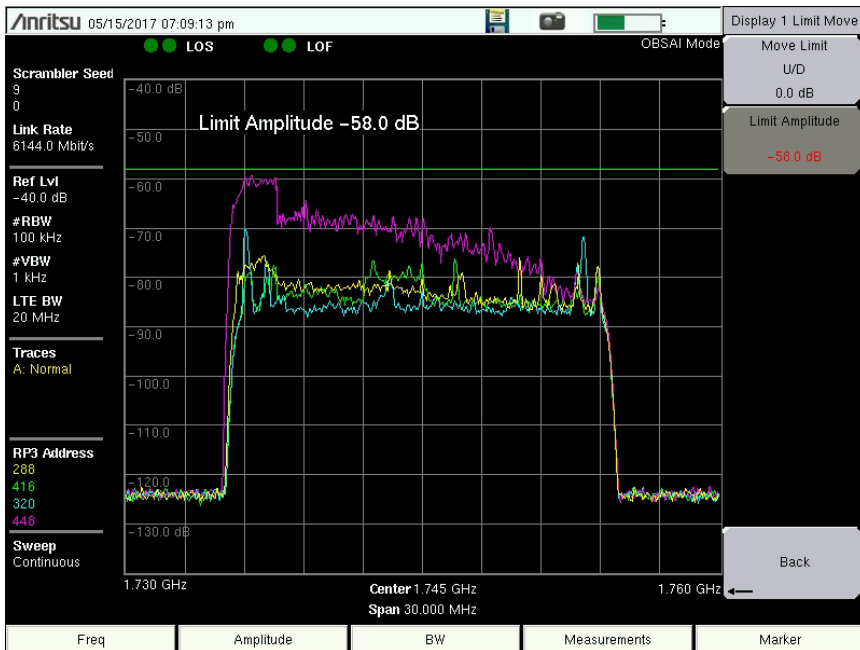


Figure 2-52. Limit Line Example

2-31 Save Menu

Key Sequence: **Shift > Limit (6) > Save Limit**

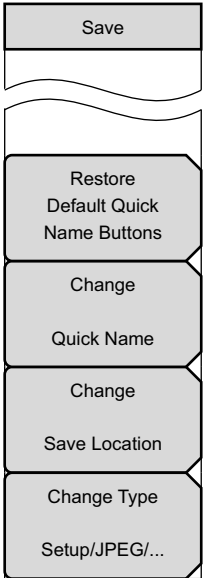
	<p>Use the touch screen keyboard illustrated in Figure 2-54 to type the desired file name in the Filename edit box. Optionally, you can use the Quick Name keys to insert preset text strings into the file name.</p> <p>Press Enter to save, Esc to close the Save dialog without saving.</p> <p>Restore Default Quick Name Buttons: Press this key to reset to their factory defaults any custom Quick Names previously defined. Press Yes in the confirmation dialog to proceed.</p> <p>Change Quick Name: Press this key to define a custom text string associated with one of the Quick Name buttons at the bottom of the touch screen keyboard (see Figure 2-54). Select the Quick Name to edit as illustrated in Figure 2-55, then press Enter. In the Edit Quick Name dialog, type the new Quick Name and press Enter again. See Figure 2-56. The new Quick Name is displayed on the button below the keyboard.</p> <p>Change Save Location: Opens the “Save Location Menu” on page 2-45.</p> <p>Change Type Setup/JPEG/... Press this key if you want to save data other than limit lines.</p>
-----------------------------------------------------------------------------------	-------------------------------------------------------------------------------------------------------------------------------------------------------------------------------------------------------------------------------------------------------------------------------------------------------------------------------------------------------------------------------------------------------------------------------------------------------------------------------------------------------------------------------------------------------------------------------------------------------------------------------------------------------------------------------------------------------------------------------------------------------------------------------------------------------------------------------------------------------------------------------------------------------------------------------------------------------------------------------------------------------------------------------------------------------------------------------------------------------------------------------------------------------------------------------------------------------------------------------------------------

Figure 2-53. Save Menu

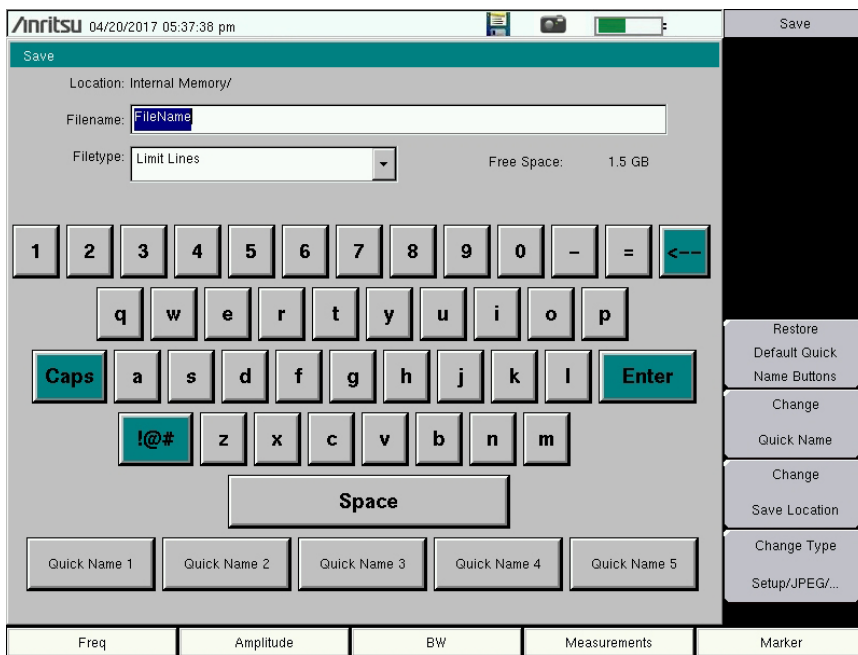


Figure 2-54. Save Dialog

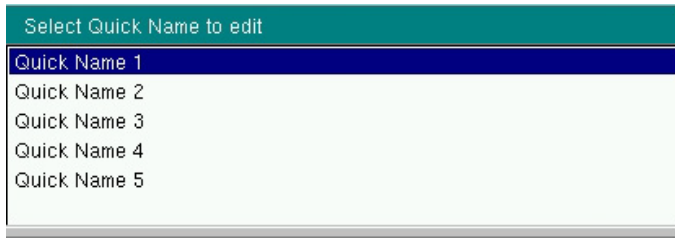


Figure 2-55. Select Quick Name List Box

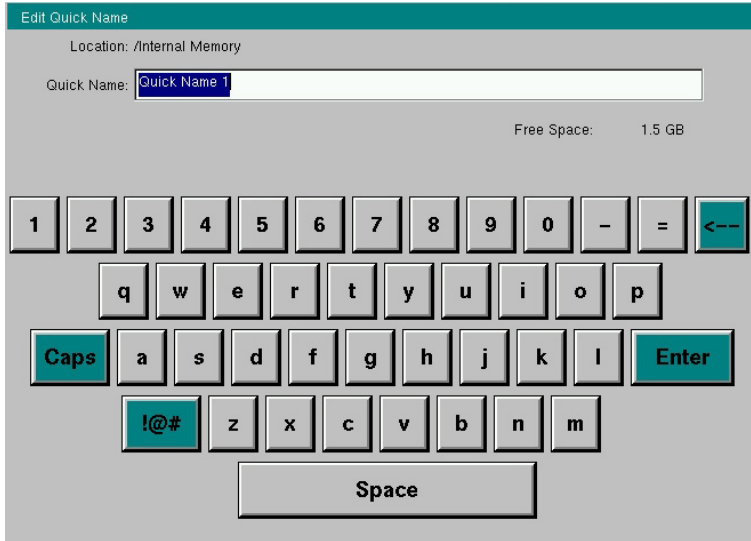


Figure 2-56. Edit Quick Name Dialog Box

2-32 Save Location Menu

Key Sequence: **Shift** > **Limit (6)** > Save Limit > Change Save Location

<table border="1"> <tr><td>Save Location</td></tr> <tr><td>Sort By</td></tr> <tr><td>Name Type Date</td></tr> <tr><td>Sort Order</td></tr> <tr><td>Ascend Descend</td></tr> <tr><td>Create</td></tr> <tr><td>Folder</td></tr> <tr><td>Set</td></tr> <tr><td>Location</td></tr> <tr><td>Refresh</td></tr> <tr><td>Directories</td></tr> </table>	Save Location	Sort By	Name Type Date	Sort Order	Ascend Descend	Create	Folder	Set	Location	Refresh	Directories	<p>You can save files to internal memory or a USB storage device. Use the touch screen, Up/Down arrow keys, or rotary knob to select the folder, then press Set Location.</p> <p>Sort By Name Type Date: Press this key to choose the item by which folders are sorted in the Select Save Location list. See Figure 2-58.</p> <p>Sort Order Ascend Descend: Toggles the sort order of the folder list between Ascending and Descending.</p> <p>Create Folder: Press this key to create a new folder inside the selected directory. Enter the new folder name in the Create Directory dialog and press Enter (see Figure 2-59 on page 2-46). To return to the Select Save Location dialog without creating a new folder, press Esc.</p> <p>Set Location: Press this key to set the currently selected folder as the destination where saved files will be stored, and to return to the “Save Menu” on page 2-43.</p> <p>Refresh Directories: Press this key to update the folder list after connecting or disconnecting an external USB drive.</p>
Save Location												
Sort By												
Name Type Date												
Sort Order												
Ascend Descend												
Create												
Folder												
Set												
Location												
Refresh												
Directories												

Figure 2-57. Save Location Menu

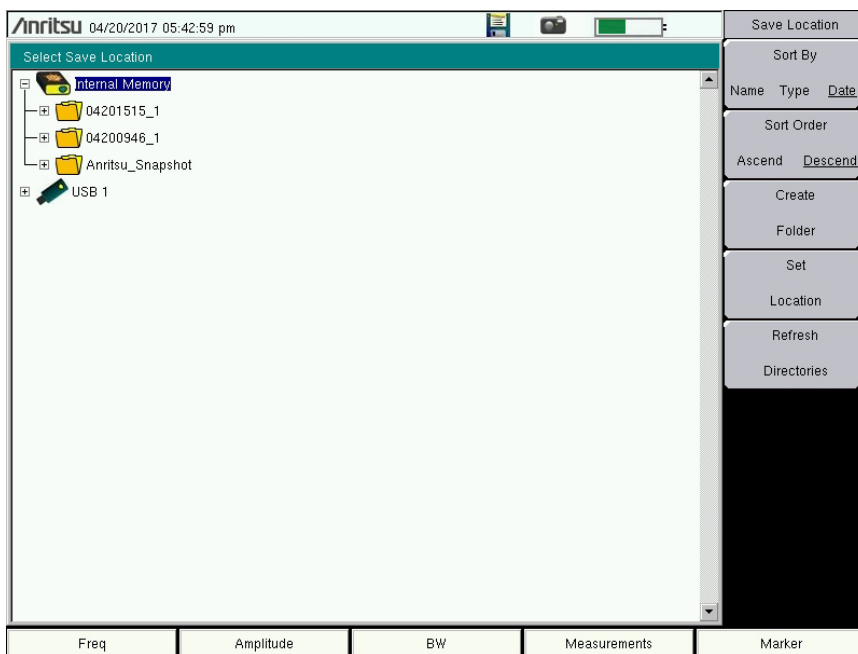


Figure 2-58. Select Save Location

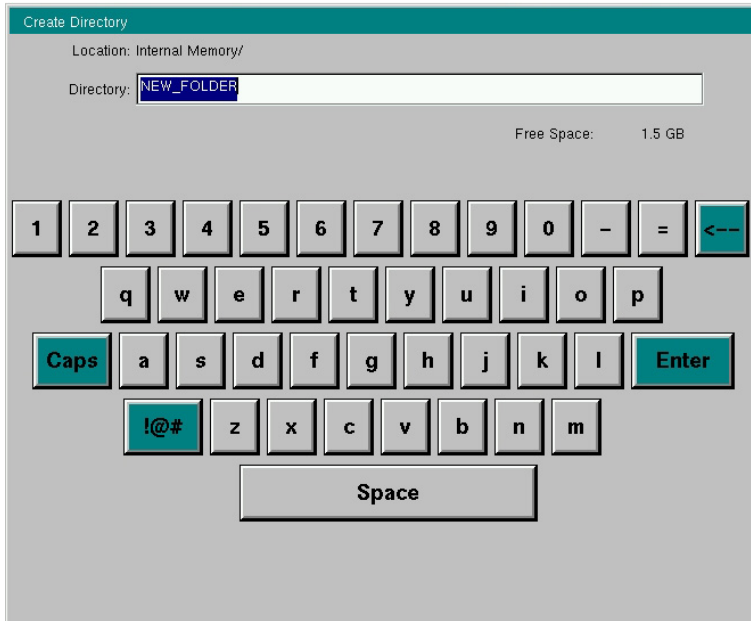


Figure 2-59. Create Directory

2-33 Recall Menu

Key Sequence: **Shift** > **Limit (6)** > Recall Limit

<div style="border: 1px solid black; padding: 5px; margin-bottom: 5px;">Recall</div> <div style="border: 1px solid black; padding: 5px; margin-bottom: 5px;">Sort By Name Type <u>Date</u></div> <div style="border: 1px solid black; padding: 5px; margin-bottom: 5px;">Sort Order Ascend <u>Descend</u></div> <div style="border: 1px solid black; padding: 5px; margin-bottom: 5px;">File Type</div> <div style="border: 1px solid black; padding: 5px; margin-bottom: 5px;">Limit Lines</div> <div style="border: 1px solid black; padding: 5px; margin-bottom: 5px;">Refresh</div> <div style="border: 1px solid black; padding: 5px;">Directories</div>	<p>You can recall a previously saved Limit Lines file from internal memory or a USB storage device. Select the file in the Recall dialog, then press Enter.</p> <p>Sort By Name Type Date: Press this key to choose the item by which folders and files are sorted in the Recall dialog box. See Figure 2-61.</p> <p>Sort Order Ascend Descend: Press this key to toggle the sort order of the file list between Ascending and Descending.</p> <p>File Type: Press this key if you want to recall a different type of file. Select the file type in the Select File Type list box illustrated in Figure 2-62, then press Enter to apply the selection.</p> <p>Alternatively, you can select directly from the Filetype drop down list in the Recall dialog. JPEG image files cannot be recalled and are not listed.</p> <p>Refresh Directories: Press this key to update the file list after connecting or disconnecting an external USB drive.</p>
-----------------------------------------------------------------------------------------------------------------------------------------------------------------------------------------------------------------------------------------------------------------------------------------------------------------------------------------------------------------------------------------------------------------------------------------------------------------------------------------------------------------------------------------------------------------------------------------------------------------------------------------------------------------------	-----------------------------------------------------------------------------------------------------------------------------------------------------------------------------------------------------------------------------------------------------------------------------------------------------------------------------------------------------------------------------------------------------------------------------------------------------------------------------------------------------------------------------------------------------------------------------------------------------------------------------------------------------------------------------------------------------------------------------------------------------------------------------------------------------------------------------------------------------------------------------------------------------------------------------------------------------------------------------------------------------------------------------------------------------

Figure 2-60. Recall Menu

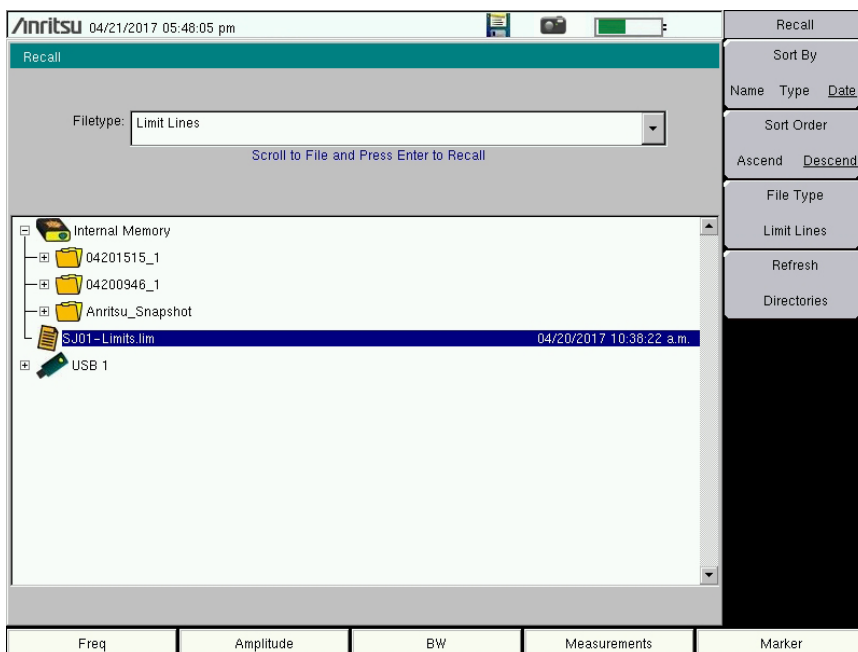


Figure 2-61. Recall Dialog

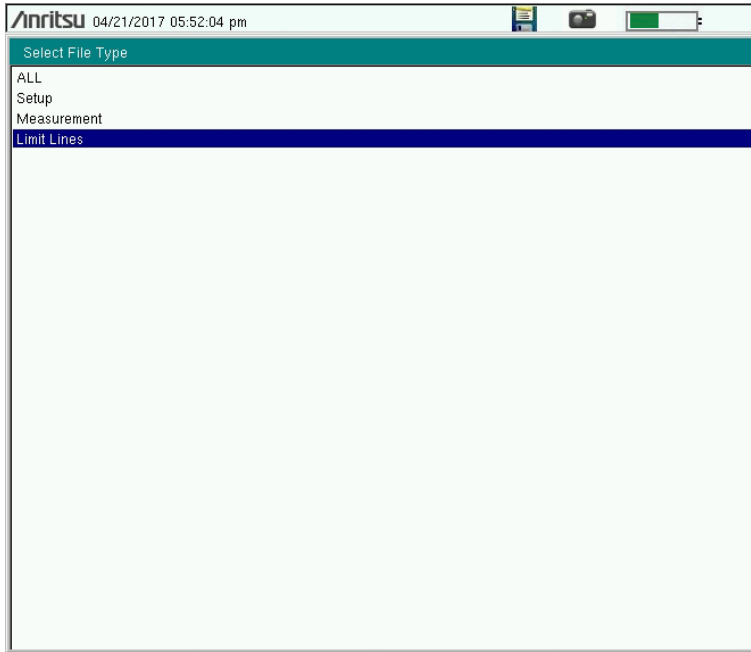


Figure 2-62. Select File Type

Index

- A**
- alarm
 - limit alarm 2-41
 - OBSAI alarm 2-21
 - Amplitude menu 2-19
 - Anritsu, contact 1-2
- B**
- bandwidth 2-5, 2-20, 2-24
 - BW menu 2-20
- C**
- change directory 2-43
 - Config menu 2-23
 - contacting Anritsu 1-2
 - create folder 2-45
- D**
- delta marker 2-33
- F**
- Freq menu 2-15
- L**
- Limit
 - alarm 2-41
 - menu 2-41
 - menu map 2-14
 - Move menu 2-42
 - recall 2-47
 - save 2-43
 - link rate 2-4, 2-23
 - links, contact 1-2
 - LTE
 - bandwidth 2-5, 2-24
- M**
- marker
 - delta 2-33
 - menu 2-33
 - table 2-35
 - Max Hold submenu key 2-38
 - Measure menu 2-21
- menu
- Amplitude 2-19
 - BW 2-20
 - Freq 2-15
 - Limit 2-41
 - Limit Move 2-42
 - Marker 2-33
 - Measure 2-21
 - OBSAI Config 2-23
 - OBSAI SFP Data 2-31
 - Recall 2-47
 - Save 2-43
 - Save Location 2-45
 - Span 2-18
 - Spectrogram 2-28
 - Spectrum 2-27
 - Sweep 2-36
 - Trace 2-37
 - Trace A Ops 2-38
 - Trace B Ops 2-39
 - Trace C Ops 2-40
- menu map 2-9
- Limit 2-14
 - Measurements 2-11
 - Sweep 2-13
 - Trace 2-13
- Min Hold submenu key 2-38
- O**
- OBSAI
- alarms 2-21
 - Config menu 2-23
 - configuration 2-8
 - link rate 2-4, 2-23
 - Measurements menu map 2-11
 - menu map 2-9
 - SFP Data menu 2-31
 - Spectrogram menu 2-28
 - Spectrum menu 2-27
 - Option 753 2-1
 - Option 759 2-1
- P**
- pan 2-15
- Q**
- Quick Name 2-43

R

Recall limit 2-47
refresh directories 2-45, 2-47
RP3 address 2-4, 2-26

S

Save
 limit 2-43
 location 2-45

SFP
 compliance info 2-31
 Data menu 2-31

Span menu 2-18

Spectrogram
 menu 2-28
 recording time 2-28
 view 2-7

Spectrum
 menu 2-27
 view 2-6

Sweep
 menu 2-36
 menu map 2-13

T

Trace A Ops menu 2-38
Trace B Ops menu 2-39
Trace C Ops menu 2-40
Trace menu 2-37
Trace menu map 2-13

W

web links, contact 1-2

Z

zoom 2-15

Anritsu



Anritsu utilizes recycled paper and environmentally conscious inks and toner.

Anritsu Company
490 Jarvis Drive
Morgan Hill, CA 95037-2809
USA
<http://www.anritsu.com>