

Measurement Guide

Digital Television Signal Analyzer for Anritsu RF and Microwave Handheld Instruments

BTS Master™

Spectrum Master™

Cell Master™

Digital Broadcast Field Analyzer, MS8911B Spectrum Master™

ISDB-T	Option 30
ISDB-T SFN	Option 32
ISDB-T BER	Option 79 (requires Option 30)
DVB-T/H BER	Option 57 (requires Option 64 or MS8911B-0050)
DVB-T/H	Option 64 and Option MS8911B-0050
DVB-T/H SFN	Option 78 and Option MS8911B-0052

Note

Not all instrument models offer every option. Please refer to the Technical Data Sheet of your instrument for available options.



Table of Contents

Chapter 1—Signal Analyzer Overview

1-1	Introduction	1-1
	Terminology	1-2
1-2	Contacting Anritsu	1-2
1-3	Selecting a DTV Measurement Mode	1-2
1-4	Main Menu Keys	1-3
1-5	Instrument Connections	1-3
1-6	Digital Television Signal Analyzer Technology	1-4
	DVB-T/H and ISDB-T	1-4
	DVB-T/H	1-4
	Guard Intervals	1-7
	FFT Start	1-7

Chapter 2—DVB-T/H Signal Analyzer

2-1	Introduction	2-1
2-2	Instrument Connections	2-1
2-3	Digital Television Signal Analyzer Technology	2-1
2-4	DVB-T/H	2-2
	DVB-T	2-2
	DVB-H	2-3
	2K, 4K, 8K Modes and Guard Intervals	2-3
	FFT Start	2-4
	Time-Slicing	2-4
	MPE-FEC	2-4
	Hierarchical Modulation	2-5
2-5	Measurement Functions	2-10
	RF Measurements	2-10
	Modulation Analysis Measurements	2-13
	BER Measurements (Option 57)	2-15
2-6	Automatic Detection of Parameters	2-16
2-7	General Measurement Setups	2-19
2-8	Antenna Setup	2-19
2-9	Setting up the Measurement Frequency	2-20
	To Set Measurement Frequency by Entering Center Frequency	2-20
	To Set Measurement Frequency by Selecting a Signal Standard	2-21
2-10	Bandwidth Setup	2-21
2-11	Amplitude Setup	2-22

Table of Contents (Continued)

2-12	Quick Measurement Setup	2-23
2-13	DVB-T/H RF Measurements	2-25
	Signal Power	2-25
	Spectrum Monitor	2-27
	Shoulder Attenuation	2-29
2-14	DVB-T/H Modulation Measurements	2-30
	Composite View	2-30
	Constellation	2-32
	Impulse Response	2-33
	Carrier MER	2-35
2-15	DVB-T/H BER Measurements (Option 57 only)	2-37
2-16	DVB-T/H Menus	2-40
	Main Menu Group	2-40
	RF Measurement Menus Group	2-41
	Modulation Analysis Menus Group	2-42
	BER Menu Group	2-43
2-17	Frequency Menu	2-44
2-18	Signal Standard Menu	2-45
2-19	Amplitude Menu	2-46
	Reference Level, Input Attenuation, and Preamplifier Setting	2-47
2-20	Meas Setup Menu	2-48
	Meas Mode Settings	2-49
2-21	Advanced Settings Menu	2-50
2-22	Meas Selection Menu	2-51
2-23	Marker Menu	2-52
	Marker Description	2-52
2-24	RF Measurements Menu	2-53
2-25	Signal Power Menu	2-53
2-26	Spectrum Monitor Menu	2-54
2-27	Modulation Analysis Menu	2-55
2-28	Constellation Menu	2-55
2-29	Impulse Response Menu	2-56
2-30	Vertical Range Menu (Impulse Response)	2-57
2-31	Carrier MER Menu	2-58
2-32	Vertical Range Menu (Carrier MER)	2-58
2-33	BER Setup (1/2) Menu (Option 57 Only)	2-59
	Service	2-59
	BER Measurement Point	2-60

Table of Contents (Continued)

2-34	BER Bit Count Setting Menu (Option 57 Only)	2-60
2-35	BER Setup (2/2) Menu (Option 57 Only)	2-61

Chapter 3—DVB-T/H SFN Signal Analyzer

3-1	Introduction	3-1
3-2	Instrument Connections	3-1
3-3	Digital Television Signal Analyzer Technology	3-1
3-4	Measurement Functions	3-2
	Impulse Response Measurement	3-2
	Inband Spectrum Measurement	3-3
3-5	General Measurement Setups	3-4
	Antenna Setup	3-4
	Setting up the Measurement Frequency	3-4
	Bandwidth Setup	3-5
	Amplitude Setup	3-5
	Measurement Setup	3-5
3-6	Impulse Response Measurements	3-7
3-7	Inband Spectrum Measurements	3-7
3-8	DVB-T/H SFN Menus	3-8
	Main Menu Group	3-8
	Measurements Menu Group	3-9
	Marker Menu Group	3-10
3-9	Freq (Frequency) Menu	3-11
3-10	Amplitude Menu	3-12
3-11	Meas Setup (1/2) Menu 5	3-14
	Measurement Mode	3-14
3-12	Meas Setup (2/2) Menu	3-15
3-13	Measurements Menu	3-16
3-14	Impulse Response Menu	3-16
3-15	Vertical Range (Impulse Response) Menu	3-17
3-16	Display Waveform Menu	3-18
3-17	Inband Spectrum Menu	3-19
3-18	Vertical Range (Inband Spectrum) Menu	3-19
3-19	Marker Menu (Impulse Response)	3-20
3-20	Marker Menu (Inband Spectrum)	3-21

Chapter 4—ISDB-T Signal Analyzer

4-1	Introduction	4-1
4-2	Instrument Connections	4-2

Table of Contents (Continued)

4-3	Digital Television Signal Analyzer Technology	4-2
4-4	Chapter Topics	4-3
4-5	ISDB-T Signal Analyzer Technology	4-4
	Modes 1, 2, and 3	4-4
	Guard Intervals	4-4
	FFT Start	4-4
4-6	Quick Start Configuration, Setup, and Testing	4-5
	Antenna Setup	4-5
	Frequency and Reference Level Configurations	4-6
4-7	Batch, Easy, and Custom Setup Procedures	4-7
4-8	Batch Measurement Setup	4-9
	Batch Measurement Preparation	4-9
	Batch Setup	4-11
	Batch Measurements	4-13
4-9	Easy Measurement Setup	4-15
	General Easy Setup	4-15
	Field Strength Measurement Setup	4-15
	Modulation Analysis Setup	4-16
	Spectrum Mask Setup	4-16
	Spurious Emissions Setup	4-17
	Save the Test Results	4-17
	Easy Measurement Parameters	4-17
4-10	Custom Measurement Setup	4-20
	General Setup Procedure	4-20
4-11	Field Strength Measurement, Custom	4-20
4-12	Modulation Analysis, Custom	4-22
	General Setup	4-22
	Custom Modulation Analysis	4-23
	Constellation Configuration:	4-26
	Delay Profile Configuration	4-29
	Measurement Mode Selection for Modulation Analysis	4-30
4-13	Spectrum Mask, Custom	4-34
	Critical Mask Type, Brazil(Critical)	4-35
	Subcritical Mask Type, Brazil(Subcritical)	4-36
	Noncritical Mask Type, Brazil(Noncritical)	4-37
4-14	Phase Noise, Custom	4-44
4-15	Spurious Emissions, Custom	4-46
4-16	BER Measurements Setup, Custom (Option 79)	4-47
	ASI Out Connector	4-47

Table of Contents (Continued)

4-17	Spectrum Monitor, Custom	4-49
4-18	Saving the Measurement Results	4-52
	Saving a File Automatically	4-52
	Saving a File Manually	4-54
4-19	ISDB-T Menus and Measurements for Custom and Easy	4-55
	Frequency/Level Menu Group — Custom	4-56
	Frequency/Level Menu Group — Easy	4-57
	Measurement Selection Menus	4-58
	Field Strength Setup Menu Group	4-59
	Modulation Analysis Setup Menu Group	4-60
	Constellation Setup (Modulation Analysis) Menu Group	4-61
	BER Measurement Menu Group	4-63
4-20	Measurement Selection Menus	4-64
	Meas Selection (1/2) Menu (Custom and Easy)	4-64
	Meas Selection (2/2) Menu (Custom and Easy)	4-65
	Measurement Mode Selection Menus	4-66
4-21	Field Strength Measurement Setup Menus	4-67
4-22	Measurements in Custom Mode	4-68
4-23	Frequency/Level Menus (Custom Mode)	4-68
	Frequency/Level Menu for UHF Channel Map	4-68
	Frequency/Level Menu for IF Channel Map	4-70
	Frequency/Level Menu for Channel Map Setting of None	4-71
	Auto Reference Level	4-72
4-24	Meas Setup Menu – Field Strength	4-73
4-25	Select Meas Mode List Box (Custom)	4-74
	Field Strength Measurement Mode	4-74
	Modulation Analysis Measurement Mode	4-75
	Phase Noise Measurement Mode	4-75
	Spectrum Monitor Measurement Mode	4-76
4-26	Instrument Impedance or External Impedance	4-76
4-27	Meas Setup (1/2) Menu - Modulation Analysis	4-77
4-28	Meas Setup Menu - Modulation Analysis	4-78
4-29	Modulation Constellation Configuration Menu	4-79
4-30	Constellation Zoom Menus	4-80
	Constellation Zoom with Carrier MER On	4-80
	Constellation Zoom Menus (continued)	4-81
	Constellation Zoom with Carrier MER Off	4-81
4-31	Modulation Delay Profile Configuration Menu	4-82
4-32	Delay Profile Vertical Range Menu	4-83

Table of Contents (Continued)

4-33	Delay Profile Freq Response Vertical Range Menu	4-84
	Custom	4-84
4-34	Common Modulation Keys in Meas Setup (2/2) menu	4-85
	Custom	4-85
	Mode, GI	4-85
	FFT Start	4-85
	Spectrum Reverse	4-86
	TMCC Information (Custom)	4-86
4-35	Marker Menu	4-87
	Modulation Analysis, Delay Profile, Custom	4-87
4-36	Delay Profile Information Display (Custom)	4-88
	Delay Profile (All) Graph, Marker Enabled	4-91
	Delay Profile (Zoom) Graph, Marker Enabled	4-91
	Delay Profile Frequency Response Graph, Marker Enabled	4-92
	Delay Profile Frequency Response Graph, Delta Marker Enabled	4-92
4-37	Meas Setup Menu - Spectrum Mask Measurement	4-93
4-38	Meas Setup Menu - Phase Noise Measurement	4-95
	Phase Noise and Marker Function	4-96
4-39	Meas Setup Menu - Spurious Emissions	4-96
4-40	Meas Setup Menu - BER	4-97
4-41	Meas Setup Menu - Spectrum Monitor	4-98

Chapter 5—ISDB-T SFN Analyzer

5-1	Introduction	5-1
5-2	Instrument Connections	5-1
5-3	Digital Television Signal Analyzer Technology	5-1
5-4	Antenna Setup	5-2
5-5	Measurement Setup and Execution	5-3
5-6	Measurements	5-4
	Set Up the Test	5-4
	Delay Profile Measurement Setup	5-4
	Inband Spectrum Measurement Setup	5-5
	Execute the Test	5-7
	Save the Test Results	5-7
5-7	Saving Measurement Results	5-8
5-8	ISDB-T SFN Menus	5-9
	Frequency/Level Menus	5-9
	Measurement Setup Menus	5-10
	Measurement Menus Group	5-11

Table of Contents (Continued)

5-9	Frequency/Level Menu (Channel Map = UHF)	5-12
5-10	Frequency/Level Menu (Channel Map = None)	5-13
	Auto Reference Level	5-14
	Pre Amp, Reference Level, and Input Attenuator	5-15
5-11	Meas Setup (1/2) Menu	5-16
	Measurement Mode Selection	5-16
5-12	Marker Menu (Delay Profile)	5-17
5-13	Marker Menu (Inband Spectrum)	5-18
5-14	Meas Setup (2/2) (Delay Profile) Menu	5-19
	Mode, GI Relationship	5-20
	Guard Interval Lengths	5-20
5-15	Meas Setup (2/2) (Inband Spectrum) Menu	5-21
5-16	TMCC Information Menu	5-22
5-17	Correction Value Menu	5-23
5-18	Delay Profile Vertical Range Menu	5-24
5-19	Display Waveform Menu	5-25
5-20	Inband Spectrum Vertical Range Menu	5-26
	Vertical Range and Correlating dB Values	5-26

Index

Chapter 1 — Signal Analyzer Overview

1-1 Introduction

This Measurement Guide documents the Digital Television Signal Analyzer (DTV) measurement options for Anritsu handheld instruments. The options include:

- DVB-T/H (Option 64 or Option MS8911B-0050)
- DVB-T/H BER (Option 57) (Note: Requires Option 64 or Option MS8911B-0050)
- DVB-T/H SFN (Option 78 or Option MS8911B-0052)
- ISDB-T (Option 30)
- ISDB-T BER (Option 79) (Note: Requires Option 30)
- ISDB-T SFN (Option 32).

Check the user guide for your Anritsu handheld instrument to find which options are available. An option (if available) must be installed in your instrument before it can be used. Some DTV options are not available for some instruments. All of the DTV options also require Option 9, IQ Demodulation Hardware in Spectrum Master instruments.

The MS8911B Digital Broadcast Field Analyzer is a type of Spectrum Master. DVB-T/H Option MS8911B-0050 is the same firmware as Option 64, and DVB-T/H SFN Option MS8911B-0052 is the same firmware as Option 78.

Screen images of measurements, as shown in this document, are examples. The images on your instrument may differ in appearance. All possible submenu keys are displayed in menu images, although some keys are displayed only under unique setup conditions. The individual menu descriptions contain explanations of such keys.

Terminology

Table 1-1. Digital Television Signal Analyzer (DTV) Terminology

Abbreviation	Broadcast Technology
DVB-T/H	DVB-T/H: Digital Video Broadcast – Terrestrial and Handheld
DVB-T	DVB-T: Digital Video Broadcast – Terrestrial
DVB-H	DVB-H: Digital Video Broadcast – Handheld (Mobile)
DVB-T/H BER	DVB-T/H with Bit Error Rate (BER) testing
DVB-T/H SFN	DVB-T/H in a Single Frequency Network environment
ISDB-T	Integrated Services Digital Broadcast – Terrestrial
ISDB-T BER	ISDB-T with Bit Error Rate (BER) testing
ISDB-T SFN	ISDB-T in a Single Frequency Network environment

1-2 Contacting Anritsu

To contact Anritsu, please visit:

<http://www.anritsu.com/contact.asp>

From here, you can select the latest sales, select service and support contact information in your country or region, provide online feedback, complete a “Talk to Anritsu” form to have your questions answered, or obtain other services offered by Anritsu.

Updated product information can be found on the Anritsu web site:

<http://www.anritsu.com/>

Search for the product model number. The latest documentation is on the product page under the Library tab.

1-3 Selecting a DTV Measurement Mode

1. Press the **Shift** key and then press the **Mode** (9) key on the numeric keypad to open the Mode Selector list.
2. Use the directional arrow keys or the rotary knob to highlight the desired Digital Video Broadcast mode, choosing one of the four options: DVB-T/H Signal Analyzer, DVB-T/H SFN, ISDB-T, or ISDB-T SFN Analyzer.
3. Press the **Enter** key to select.

Note	DVB-T/H BER (Option 57) is an accessory option to the DVB-T/H Signal Analyzer (Option 64), and ISDB-T BER (Option 79) is an accessory option to the ISDB-T Signal Analyzer (Option 30).
-------------	---

1-4 Main Menu Keys

The 5 Main Menu Keys (also called “hard keys” in some Anritsu manuals) are located below the measurement display (sweep window). These 5 keys are used to list function-specific menus in the active menu (submenu key labels or Active Function Block). The submenu keys are also called “soft keys” in some Anritsu manuals. The 5 Main Menu keys vary in function depending upon the selected mode of operation. [Table 1-2](#) lists the Main Menu key labels for the DTV modes that are described in this measurement guide.

Table 1-2. Mode-Dependent Main Menu Keys (Located Below Measurement Display)

Mode	Key 1	Key 2	Key 3	Key 4	Key 5
DVB-T/H	Frequency	Amplitude	Setup	Measurements	Marker
DVB-T/H SFN	Frequency	Amplitude	Setup	Measurements	Marker
ISDB-T	Frequency/Level	Meas Selection	Meas Setup	Execute Measure	Save Files
ISDB-T SFN	Frequency/Level	Not Used	Meas Setup	Execute Measure	Save Files

1-5 Instrument Connections

Attach the antenna to the connector labeled Spectrum Analyzer RF In on top of the instrument. [Figure 1-1](#) is an example of an Anritsu handheld instrument that is equipped to measure DTV signals. Refer to your User Guide for a description of the connectors on your instrument.



Figure 1-1. Instrument Connectors for Digital Television Signal Analysis

1-6 Digital Television Signal Analyzer Technology

DVB-T/H and ISDB-T

2K, 4K, 8K Modes (DVB-T/H) and Modes 1, 2, and 3 (ISDB-T)

DVB-T/H and ISDB-T are multi-carrier systems that use thousands of data carriers, each of which carries QPSK (Quadrature Phase Shift Keying), 16QAM, or 64QAM data. Pilot carriers use BPSK (Binary Phase Shift Keying) or DBPSK (Differential BPSK). QAM (Quadrature Amplitude Modulation) is one available method that is used to increase the amount of information per modulation symbol.

In BPSK, 1 bit can be coded per symbol. In QPSK, 2 bits can be coded per symbol. In 16QAM, 4 bits can be coded per symbol. In 64QAM, 6 bits can be coded per symbol.

Using a smaller number of subcarriers (2K mode in DVB-T/H, or Mode 1 in ISDB-T) allows for more inter-carrier spacing and thereby provides more tolerance to echoes that are influenced by Doppler effect. Shorter symbol duration limits the maximum delay of accepted echoes. Using a larger number of subcarriers creates smaller inter-carrier spacing and provides a longer symbol duration. The choice among these modes is based upon balancing the influence of Doppler effect against the maximum delay of echoes. The number of subcarriers has no impact on the broadcast capacity. For receivers that are in motion, signal complexity evolves from the many echoes that are received (which are delayed in the time domain) and also from the frequency shift (the Doppler effect) that distorts both the incoming signal and the echoes.

DVB-T/H

DVB-T/H uses OFDM (Orthogonal Frequency Division Multiplex) transmission. All of the data carriers that are in one OFDM frame are modulated by using QPSK, 16QAM, or 64QAM. In addition, the 16QAM and 64QAM modulation can use hierarchical transmission, which changes the proportions of the constellations.

The transmitted signal is organized in OFDM frames. Each frame has a duration of T_F and consists of 68 OFDM symbols, which are numbered from 0 to 67. Each symbol contains a set of K carriers (where $K = 6817$ carriers in the 8K mode, and $K = 1705$ carriers in the 2K mode). Symbols are transmitted with a duration of T_S . In addition, each symbol is composed of 2 parts, a useful part with duration of T_U and a guard interval with duration of Δ .

OFDM signals are composed of multiple separately-modulated carriers. Each symbol can be considered to be divided into cells, which each correspond to the modulation that is carried on one carrier during one symbol. All symbols contain data and reference information. The reference information includes scattered pilot cells, continual pilot carriers, and TPS carriers.

The pilots can be used for frame, frequency, and time synchronization and also for transmission mode identification and channel estimation, as well as being used to follow the phase noise.

The proportions of the constellations depend on a hierarchical modulation parameter called alpha (α). Alpha can have 3 values: 1, 2, or 4. α is the minimum distance between any 2 constellation points that carry different High-Priority-bit (HP-bit) values divided by the minimum distance separating any 2 constellation points. [Figure 1-2 on page 1-6](#) shows examples of constellations and hierarchy settings. Images on your instrument may differ from those in this figure.

In DVB-T/H, the hierarchical system maps the data onto 16QAM or 64QAM in such a way that a QPSK stream is effectively buried within the 16QAM or 64QAM stream. In addition, the spacing between constellation states can be adjusted (by use of hierarchy settings) to protect the QPSK (HP) stream at the expense of the 16QAM or 64QAM (LP) stream. HP and LP stand for High Priority and Low Priority. This is described further in section “[Hierarchical Modulation](#)” on page 2-5.

In a 64QAM constellation using hierarchical modulation, the two most significant bits (MSB) would be used for robust mobile service. The remaining 4 bits could contain an HDTV service (for example). The first two MSB (most significant bits) correspond to a QPSK service that is embedded in the 64QAM service.

Good quality reception allows receivers to resolve the entire 64QAM constellation. In areas with reception of poorer quality, or in the case of mobile or portable reception, receivers may be able to resolve only those portions of the constellation that correspond to QPSK (the High Priority stream).

[Figure 1-2](#) shows constellations and hierarchy settings (from top to bottom) as follows:

- Hierarchy None or Hierarchy 1 for QPSK
- Hierarchy None or Hierarchy 1 for 16QAM and 64QAM
- Hierarchy 2 for 16QAM and 64QAM
- Hierarchy 4 for 16QAM and 64QAM

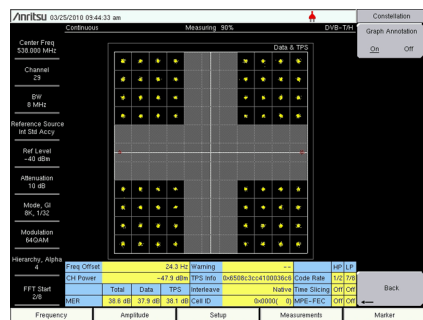
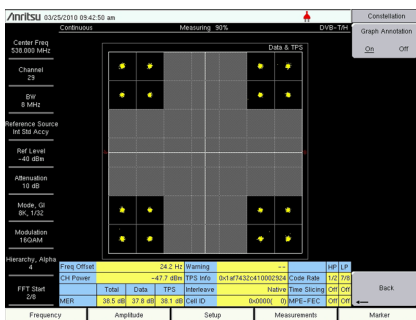
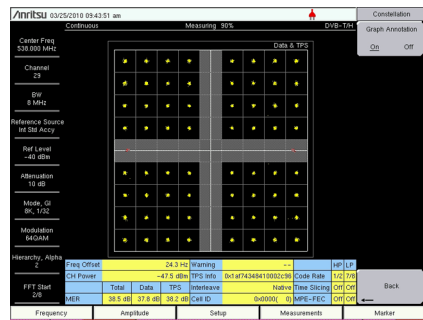
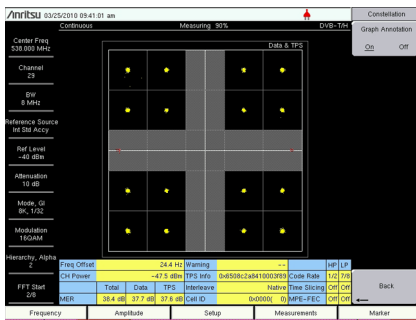
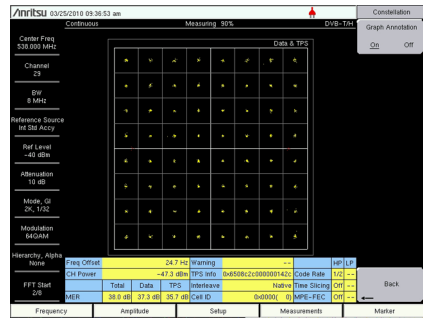
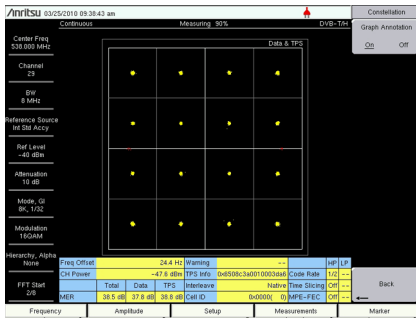
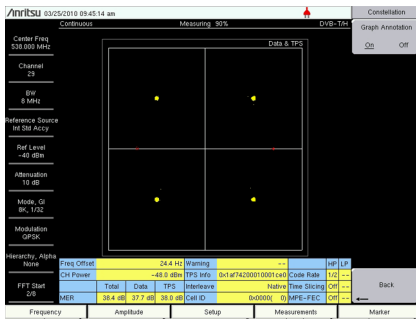


Figure 1-2. DVB-T/H Modulation and Hierarchy Settings

Guard Intervals

In order to decrease symbol interference and to reduce sensitivity to time synchronization problems, each OFDM (Orthogonal Frequency Division Multiplexing) symbol is extended by a guard interval (GI), placing a copy of the end of the OFDM symbol at the front of the symbol, thereby creating a cyclic prefix. The width of a guard interval can be 1/4, 1/8, 1/16, or 1/32 the length of the original symbol. This fraction represents the ratio between the guard interval and the active symbol period. The overall data capacity is reduced by the same fractional proportion. The fraction size of the Guard Interval is selected by using the **Mode, GI** submenu key. Refer to the **Mode, GI** submenu key in the following locations:

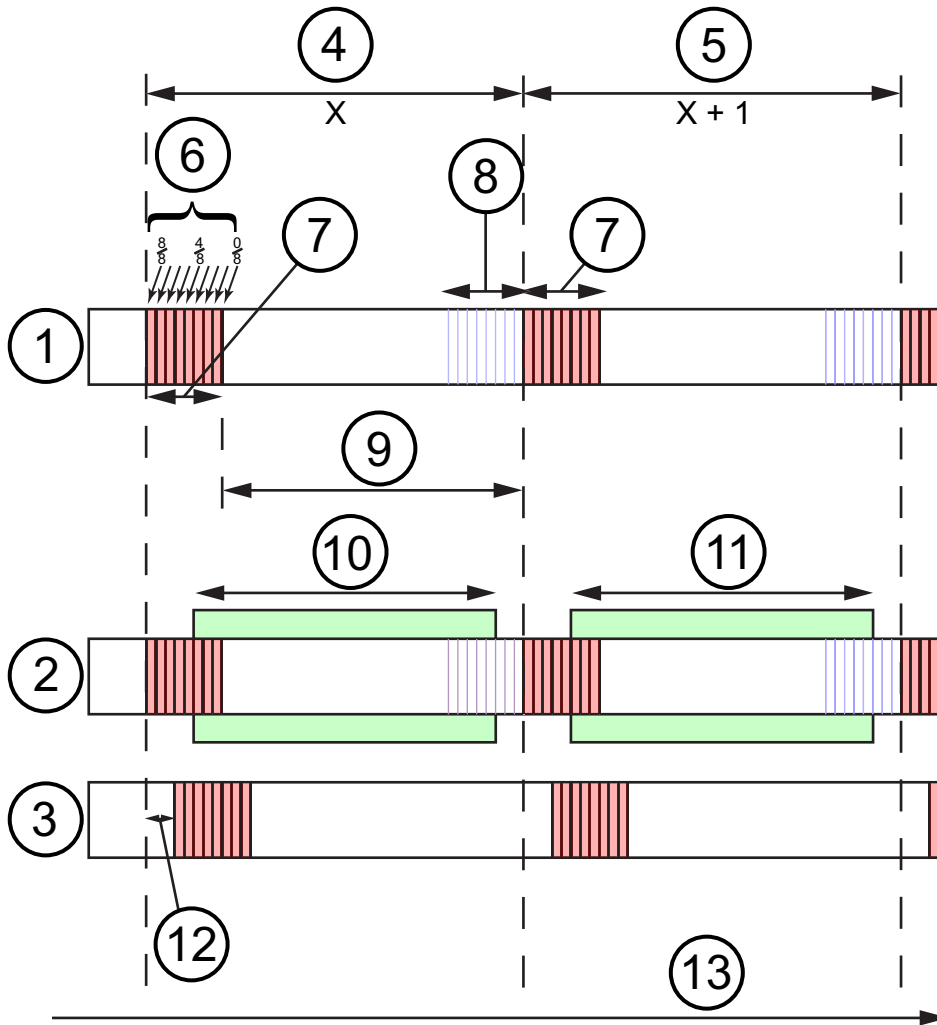
- DVB-T/H “**Mode, GI**” on page 2-50
- DVB-T/H SFN “**Mode, GI**” on page 3-15
- ISDB-T “**Common Modulation Keys in Meas Setup (2/2) menu**” on page 4-85
- ISDB-T SFN “**Mode GI**” on page 5-19

Guard Intervals are used to ensure that distinct transmissions do not interfere with one another. Guard Intervals introduce immunity to propagation delays, echoes, and reflection, to which digital data is normally very sensitive. A GI at the beginning of each symbol allows time for echoes to fade before the active symbol period begins. Protection is inversely proportional to data rate efficiency. A 1/32 GI (smallest size) gives high data rate efficiency and the lowest protection, while a 1/4 GI (largest size) provides the best protection but the lowest data rate efficiency. Guard Intervals help to reduce echo interference at the receiver if the duration of the echoes does not exceed the duration of the guard interval.

Figure 1-3 illustrates a Guard Interval that is one-fourth of the effective symbol. Note that it could also have been one-eighth, one-sixteenth, or one-thirty-second of the length of the Effective Symbol.

FFT Start

The FFT Start position is used to synchronize the reading of the OFDM frame. The start can be set at the end of the complete Guard Interval (GI), at the beginning of the GI, or can be set to include only a fraction of the GI, which is divided into eight parts. In other words, the FFT Start may be set in eighths, from 08 (none of the GI) to 88 (all of the GI). This control is used in the modulation analysis measurements and the transmitter carrier MER measurements. The flexibility that is provided by a selection of FFT Start positions allows synchronizing with a strong signal. Refer to **Figure 1-3**.



1	Direct Wave with Guard Interval shown
2	Direct Wave with FFT Window shown
3	Delayed Wave with Guard Interval shown
4	Symbol X, Length with 1/4 Guard Interval (GI is 1/4 the length of the Effective Symbol)
5	Symbol X+1, Length with 1/4 Guard Interval
6	FFT Start Positions (a fraction of the Guard Interval) — Refer to “FFT Start” on page 1-7
7	Guard Interval (GI) — Refer to “Guard Intervals” on page 1-7
8	Source of Guard Interval (copied to front of effective Symbol)
9	Effective Symbol (Data) within Direct Wave
10	FFT Window with 3/8 GI in Symbol X
11	FFT Window with 3/8 GI in Symbol X+1
12	Delay Time
13	Time

Figure 1-3. FFT Start and Guard Interval

Chapter 2 — DVB-T/H Signal Analyzer

(Option 64, Option MS8911B-0050)

2-1 Introduction

This chapter describes DVB-T/H setup and measurement for signal power and signal analysis with Option 64 (or Option MS8911B-0050) and for Bit Error Rate (BER) testing with Option 57. Note that Option 9 (IQ Demodulation Hardware) may be required in your instrument in order to use Option 57 and Option 64. Digital Video Broadcasting (Terrestrial and Handheld) is abbreviated as DVB-T/H.

The main menu keys in this instrument mode are:

Frequency Amplitude Setup Measurements Marker

Screen images of measurements, as shown in this document, are examples. The images on your instrument may differ in appearance.

2-2 Instrument Connections

Attach the antenna to the connector labeled Spectrum Analyzer RF In on top of the instrument. [Figure 1-1 on page 1-3](#) is an example of an Anritsu handheld instrument. Refer to your User Guide for a description of the connectors on your instrument.

2-3 Digital Television Signal Analyzer Technology

Carrier modes, OFDM carriers, Guard Intervals and the FFT Start position are described in [Chapter 1, Section 1-6 “Digital Television Signal Analyzer Technology” on page 1-4](#).

2-4 DVB-T/H

Digital Video Broadcast – Terrestrial and Handheld (DVB-T/H)

DVB-T

DVB-T (terrestrial DVB) is a multi-carrier system that uses approximately 2000 data carriers or 8000 data carriers, each of which carries QPSK (Quadrature Phase Shift Keying), 16QAM, or 64QAM data. Pilot carriers use BPSK (Binary Phase Shift Keying) or DBPSK (Differential BPSK). For more information about Phase Shift Keying, refer to [Section 1-6 “Digital Television Signal Analyzer Technology”](#) on page 1-4.

Figure 2-1 shows a 64QAM constellation graph. The Instrument Settings Summary displays the Center Frequency, Channel, Bandwidth, Mode, GI setting, Modulation setting (64QAM), and FFT Start position.

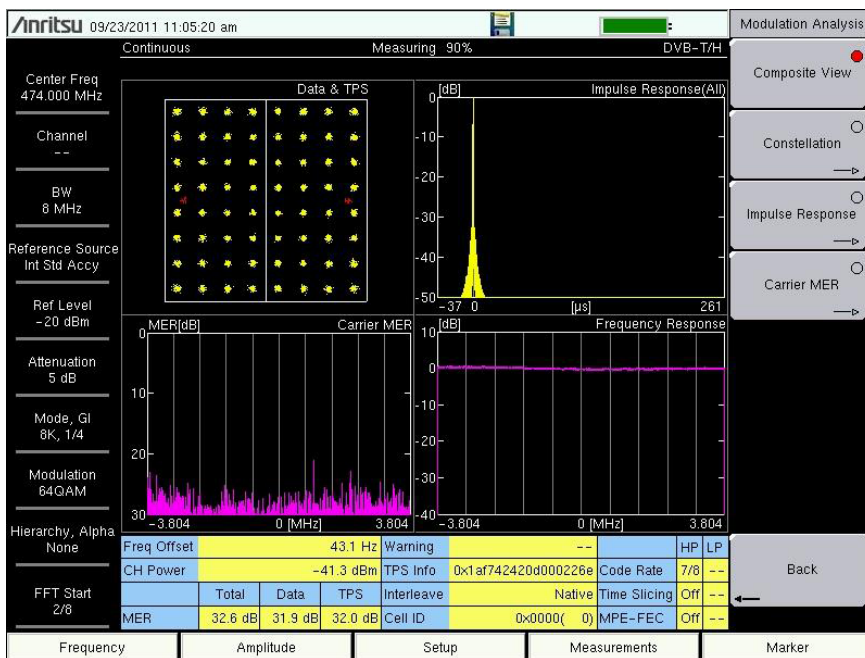


Figure 2-1. A 64QAM Constellation Graph in Composite View

When the signal is transmitted in hierarchy mode, good quality reception allows receivers to resolve the entire 64QAM constellation. In areas with reception of poorer quality, or in the case of mobile or portable reception, receivers may be able to resolve only those portions of the constellation that correspond to QPSK (the High Priority stream).

DVB-H

DVB-H (handheld or mobile DVB) uses the DVB-T transmission system as the physical layer and adds extra error correction and time-slicing mechanisms on the link layer. DVB-H carries IP datagrams that are encapsulated by using multi-protocol encapsulation. DVB-H differs from DVB-T by using approximately 4000 data carriers (with QPSK, 16QAM, or 64QAM) as well as 2000 data carriers or 8000 data carriers.

A full DVB-H system is defined by combining elements in the physical and link layers as well as service information. DVB-H makes use of the following technology elements for the link layer and the physical layer:

Link Layer

- Time-slicing to reduce average power consumption of terminal and to enable smooth and seamless frequency handover
- Forward error correction for multi-protocol encapsulated data (MPE-FEC) for improvement in the C/N (carrier-to-noise ratio) and Doppler performance in mobile channels, also improving tolerance to impulse interference

MPE-FEC: Forward Error Correction (FEC) at the Multi-Protocol Encapsulation (MPE) layer

Physical Layer

DVB-T plus the following technical elements that are specifically targeting DVB-H use:

- DVB-H signaling in TPS-bits (Transmission Parameter Signaling bits) to enhance and speed up service discovery. A cell identifier is also carried on TPS-bits in order to support faster signal scan and frequency handover on mobile receivers.
- 4K mode (3409 carriers) for trading off mobility and SFN (single frequency network) cell size, allowing single antenna reception in medium SFNs at very high speed, thus adding flexibility in the network design.
- Optional in-depth symbol interleaver for 2K mode (1705 carriers) and 4K mode (3409 carriers) for further improving robustness in mobile environment conditions and improving impulse noise conditions.
- Transmission parameters to operate transmission system in 5 MHz channel bandwidth, even outside traditional broadcasting bands.

TPS signals are used to send the parameters of the transmitted signal and to identify the transmission cell. Mobile handover execution is based partly on TPS information. Pilot signals are used during the synchronization and equalization phase. The receiver must be able to synchronize, equalize, and decode the TPS signal in order to gain access to the information that is held by the TPS pilots. The receiver, therefore, must know this information beforehand. The TPS data is used only in special cases, such as changes in the parameters and resynchronizations.

2K, 4K, 8K Modes and Guard Intervals

The mode number and the fraction of the Effective Symbol (the Data) that is used for a Guard Interval are both chosen by pressing the **Mode, GI** submenu key in the [“Advanced Settings Menu”](#) on page 2-50 (refer to [Figure 2-36](#)). The Select Mode, GI dialog box contains the available choices. For example, selecting **8K, 1/8** means that 8K Mode will be used and that the Guard Interval will be one-eighth (1/8) the size of the effective symbol. Refer to [“Guard Intervals”](#) on page 1-7 and [Figure 1-3](#), [“FFT Start and Guard Interval”](#) on page 1-8.

FFT Start

If the FFT Start position is set to any of the GI positions (08 to 88), and if the 0 μ s position on the Impulse Response (All) graph is subsequently changed, then the FFT Start position is automatically modified by the test instrument. If the FFT Start position is set to a fixed position (08 Fixed through 88 Fixed), then the FFT Start position is not modified when the 0 μ s position is changed on the Impulse Response (All) graph.

Also, if the FFT Start position is set to a fixed position, then the Auto Detect Parameter and Detect Parameter Once functions do not change the FFT Start position setting.

Time-Slicing

The objective of time-slicing is to reduce the average power consumption of battery-powered receivers and to enable smooth and seamless service handover. Time-slicing consists of sending data in bursts using a significantly higher instantaneous bit rate compared to the bit rate required if the data were transmitted using traditional streaming mechanisms.

To indicate to the receiver when to expect the next burst, the time (Δt) to the beginning of the next burst is indicated within the burst. Between the bursts, data of the elementary stream is not transmitted, which allows other elementary DVB streams to use the bandwidth otherwise allocated. Time-slicing enables a receiver to stay active only a fraction of the time and still receive bursts of a requested service. Note that the transmitter is constantly on (in other words, the transmission of the transport stream is not interrupted).

Time-slicing also allows a receiver to monitor neighboring cells during the off-times (between bursts). By switching the reception from one transport stream to another during an off period, a better handover decision is possible as well as seamless service handover.

Time-slicing is always used in DVB-H.

MPE-FEC

The objective of MPE-FEC (forward error correction for multi-protocol encapsulated data) is to improve the C/N (carrier-to-noise ratio) and Doppler performance in mobile channels and to improve tolerance to impulse interference. This is accomplished through the introduction of an additional level of error correction at the MPE layer. By adding parity information that is calculated from the datagrams and by sending this parity data in separate MPE-FEC sections, error-free datagrams can be output after MPE-FEC decoding, even with bad reception conditions. The use of MPE-FEC is optional (as determined by the DVB-H standard). If the Network Carrier chooses to use MPE-FEC, then the MPE-FEC setting bit in the TPS packet will be set so that the receiver is aware it.

Hierarchical Modulation

In hierarchical modulation, two separate data streams are modulated onto a single DVB-T stream. One stream, called the High Priority (HP) stream, is embedded within the other stream, a Low Priority (LP) stream. Receivers with good reception conditions can receive both streams, while those with poorer reception conditions may be able to receive only the High Priority stream. Broadcasters can target two different types of DVB-T receiver with two completely different services. Typically, the LP stream is of a higher bit rate but lower robustness than the HP stream. A broadcaster could choose, for example, to deliver HDTV in the LP stream.

DVB-T/H signal analysis provides 4 choices for Hierarchy: None, 1, 2, and 4. When None is selected, the HP and LP streams are not available. The constellation arrangements for hierarchical modulation use a parameter called alpha (α), which can have one of the 3 values: 1, 2, or 4 (corresponding to the Hierarchy values).

When Graph Annotation is turned Off, the constellation graphs are divided into 4 quadrants. When Graph Annotation is turned On, additional grid lines are displayed. The grid lines vary in value and spacing depending upon the hierarchy setting.

The constellation arrangements for Hierarchy None and Hierarchy 1 are the same (although no HP and LP streams are available with Hierarchy None), as shown in the examples in [Figure 2-2, “QPSK with Hierarchy set to None”](#), [Figure 2-3, “16QAM with Hierarchy set to None”](#), and [Figure 2-4, “64QAM with Hierarchy set to None”](#). These sample images may differ from the actual screens on your instrument.

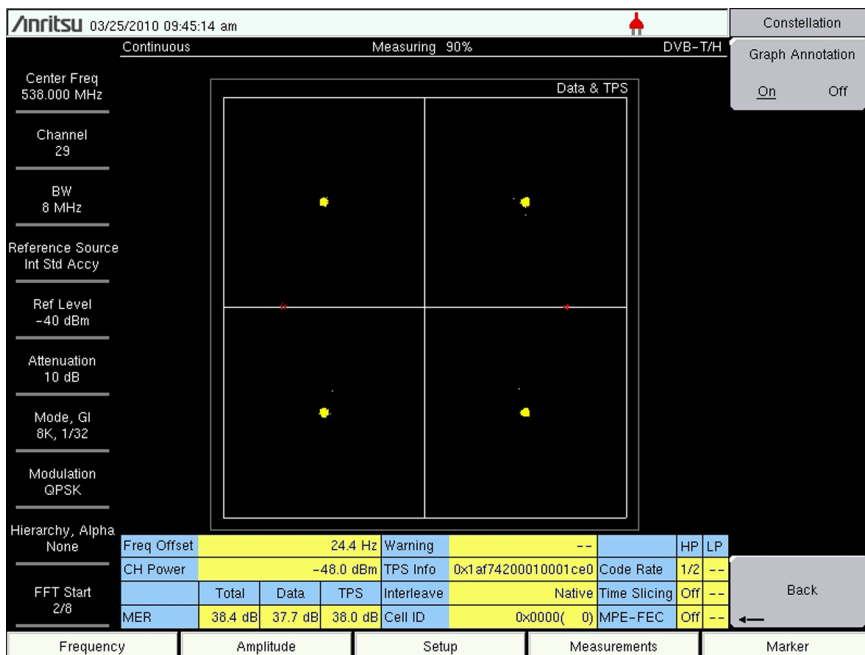


Figure 2-2. QPSK with Hierarchy set to None

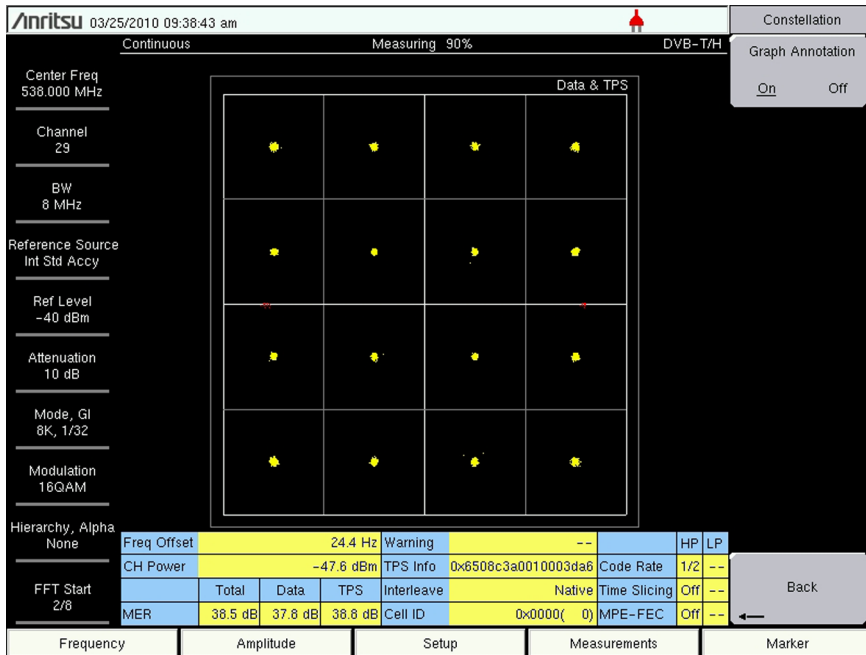


Figure 2-3. 16QAM with Hierarchy set to None

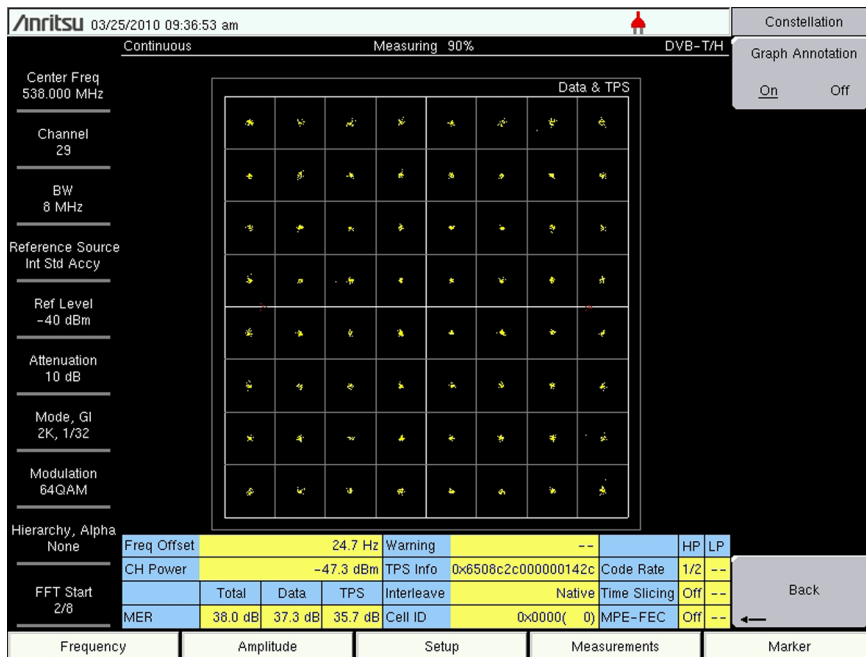


Figure 2-4. 64QAM with Hierarchy set to None

DVB-T/H Option 64 provides Graph Annotation for hierarchical modulation to display a gray area on the x-axis and y-axis through the origin, which masks the central part of the graph to indicate where the constellation points should be displayed (in the clear areas, further from the origin). Refer to [Figure 2-5](#), [Figure 2-6](#), [Figure 2-7](#), and [Figure 2-8](#). These sample images may differ from the actual screens on your instrument.

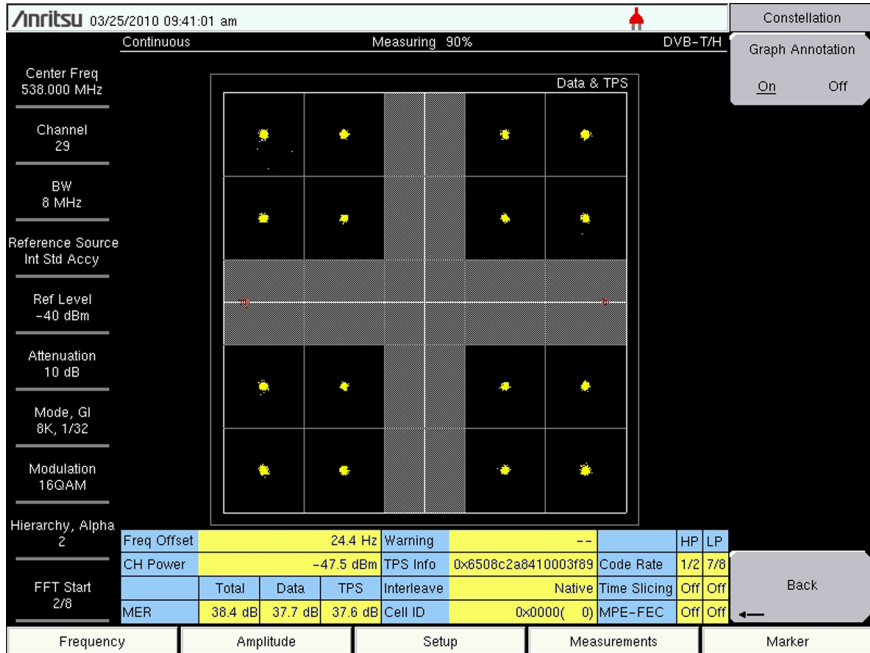


Figure 2-5. 16QAM with Hierarchy set to 2

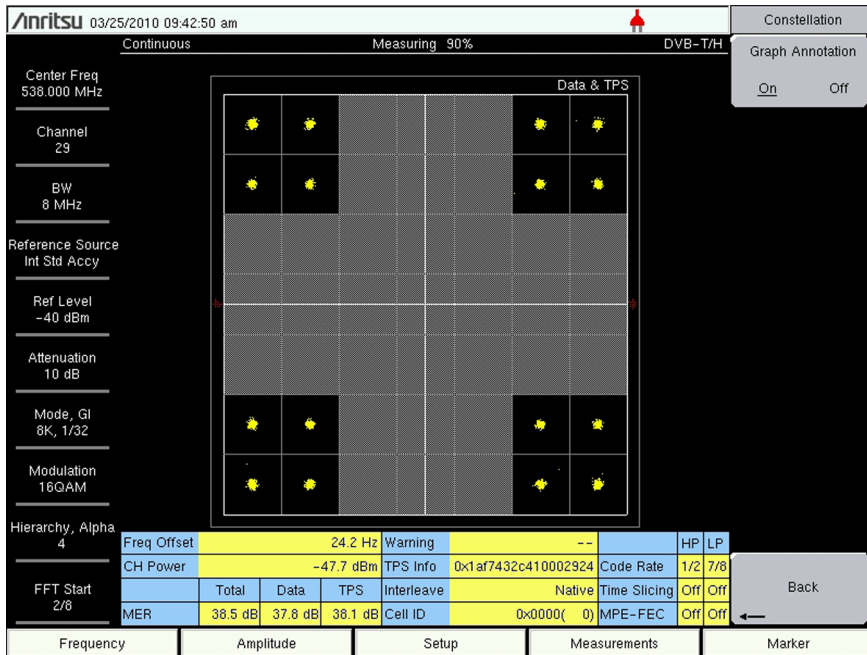


Figure 2-6. 16QAM with Hierarchy set to 4

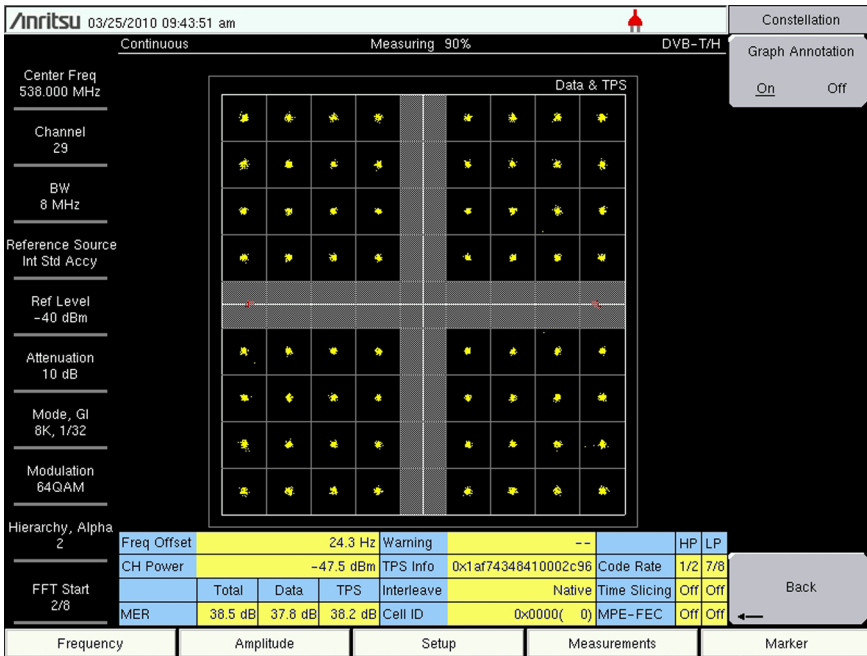


Figure 2-7. 64QAM with Hierarchy set to 2

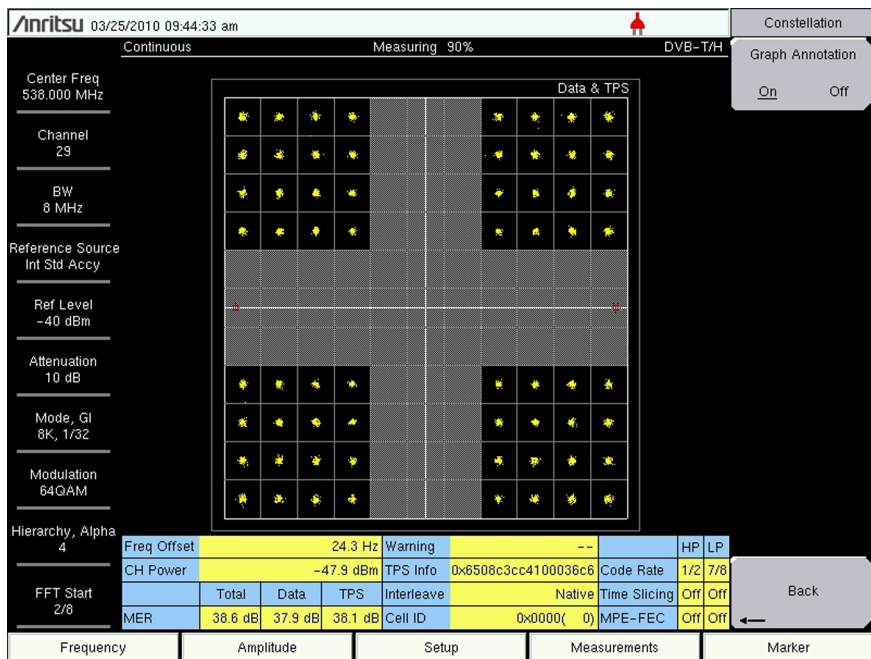


Figure 2-8. 64QAM with Hierarchy set to 4

2-5 Measurement Functions

Option 64 offers three DVB-T/H measurement functions: RF Measurements, Modulation Analysis, and (with Option 57) Bit Error Rate (BER).

RF Measurements

Three types of RF measurement can be made: Signal Power, Spectrum Monitor, and Shoulder Attenuation.

Signal Power

The Signal Power measurement is useful for adjusting antenna angles and for area surveys.

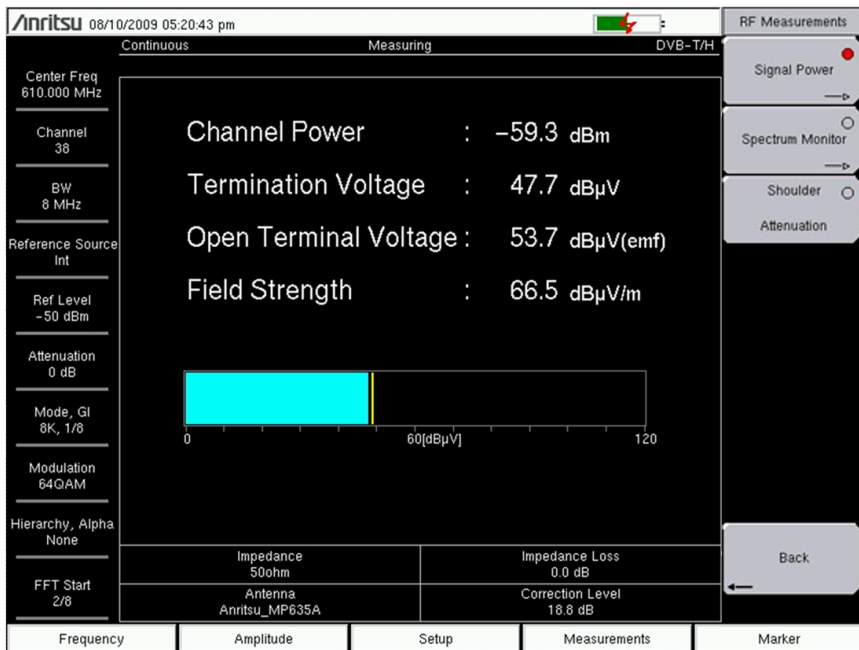


Figure 2-9. Signal Power Measurement Screen

Spectrum Monitor

The Spectrum Monitor measurement displays the frequency response around the desired channel. The variable span supports display of up to 51 channels simultaneously, so that broadcast service signals can be checked at a glance.

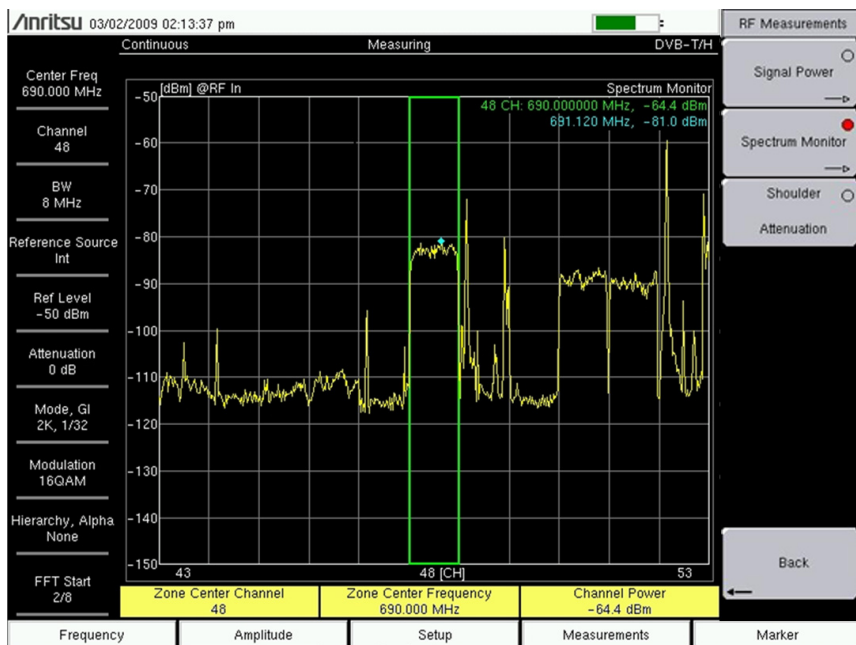


Figure 2-10. Spectrum Monitor Measurement Screen

Shoulder Attenuation

The Shoulder Attenuation measurement is performed while directly connected to the output of a transmitter. The connection is made with an attenuator or to a decoupled test point. This measurement assesses the linearity characteristics and is a valid alternative measurement to the Spectrum Mask measurement. The sample image in [Figure 2-11](#) may differ from the actual screen on your instrument.

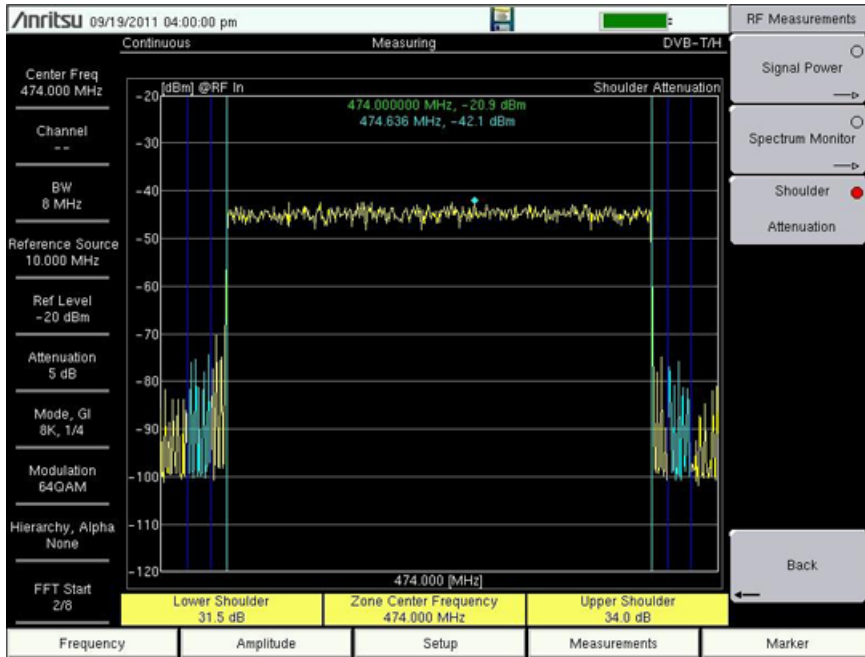


Figure 2-11. Shoulder Attenuation Measurement Screen

Modulation Analysis Measurements

Four types of Modulation Analysis measurement can be made: Constellation, Impulse Response, Carrier MER, and Frequency Response. A composite view displays all four measurements. The sample image in Figure 2-12 may differ from the actual screen on your instrument.

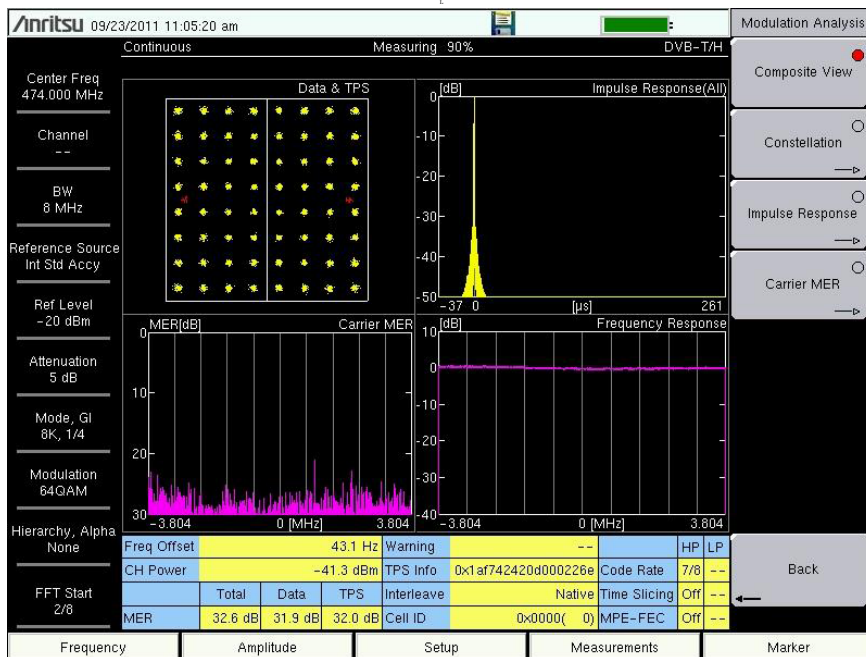


Figure 2-12. Modulation Analysis, Composite View

Measurement

The constellation function is useful for analyzing the condition of the received signal by monitoring the modulation symbol movement. In addition, this function measures the center frequency accurately by using a proprietary signal processing technique.

Impulse Response Measurement

The Impulse Response function is useful for adjusting the timing of SFN repeaters. This function measures the difference in time of multipath signals. The graph shows the existence of multipath signals and their relative power and time separation.

This measurement can be useful for choosing better locations for repeaters in order to minimize multipath problems.

Frequency Response Measurement

The Frequency Response function is useful for monitoring received signal conditions. By measuring the channel frequency response, both the multipath effect and frequency selective fading can be observed.

Carrier MER

This function is useful for transmitter installation or maintenance because it offers a wide dynamic range (50 dB) on the vertical scale for high-performance transmitters. It also offers precise checks of each carrier by providing a zoom view for all carriers on the horizontal scale.

The Modulation Error Ratio (MER) measurement function, which directly quantifies the modulation signal quality of digital broadcasting signals, is essential for managing signal margin and the fixed deterioration of equipment with time, as well as for maintaining stable broadcast services.

MER indicates signal deterioration even when BER measurement does not detect errors (error-free range). Because MER is unrelated to modulation parameters, one MER result can be compared with other MER results.

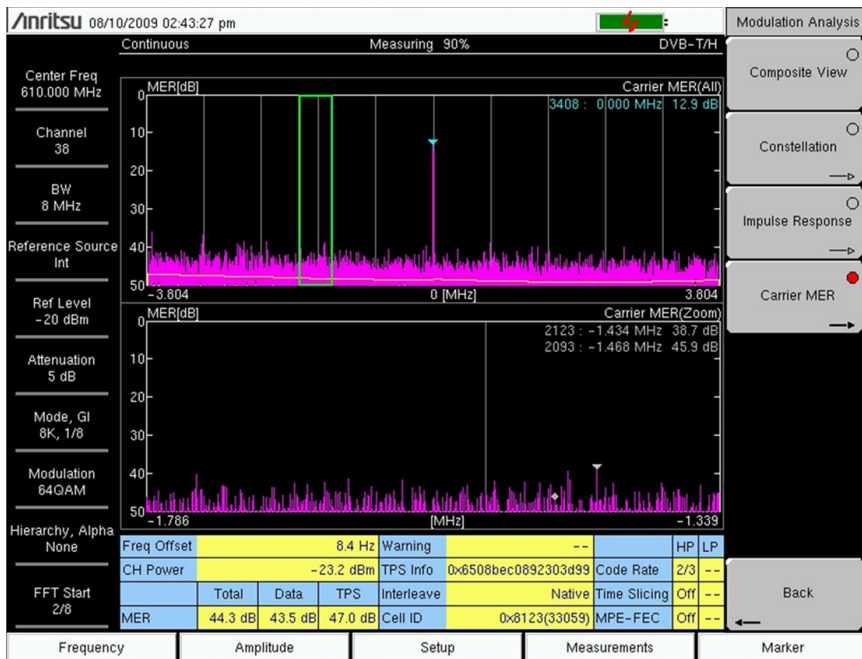


Figure 2-13. Carrier MER

BER Measurements (Option 57)

Measurement of BER is a useful tool for evaluating the quality of a broadcast signal. This option requires that additional hardware be installed in the instrument in order to perform bit error rate (BER) measurements on DVB broadcast signals. Bit Error Rate (BER) and Packet Error Rate (PER) can be measured simultaneously along with channel power and Modulation Error Ratio (MER). BER measurements also accommodate in-service and out-of-service testing.

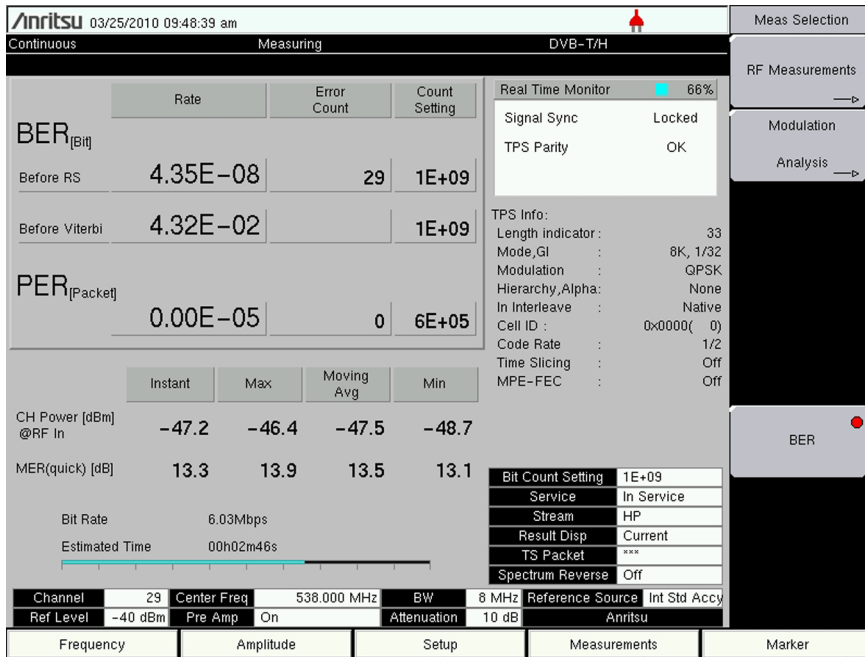


Figure 2-14. Bit Error Rate (BER) Measurements

2-6 Automatic Detection of Parameters

Two submenu keys provide automatic parameter detection. They are Auto Detect Parameter and Detect Parameter Once. The functions of these submenu keys may vary depending upon the Measurement Mode and the Measurements setting.

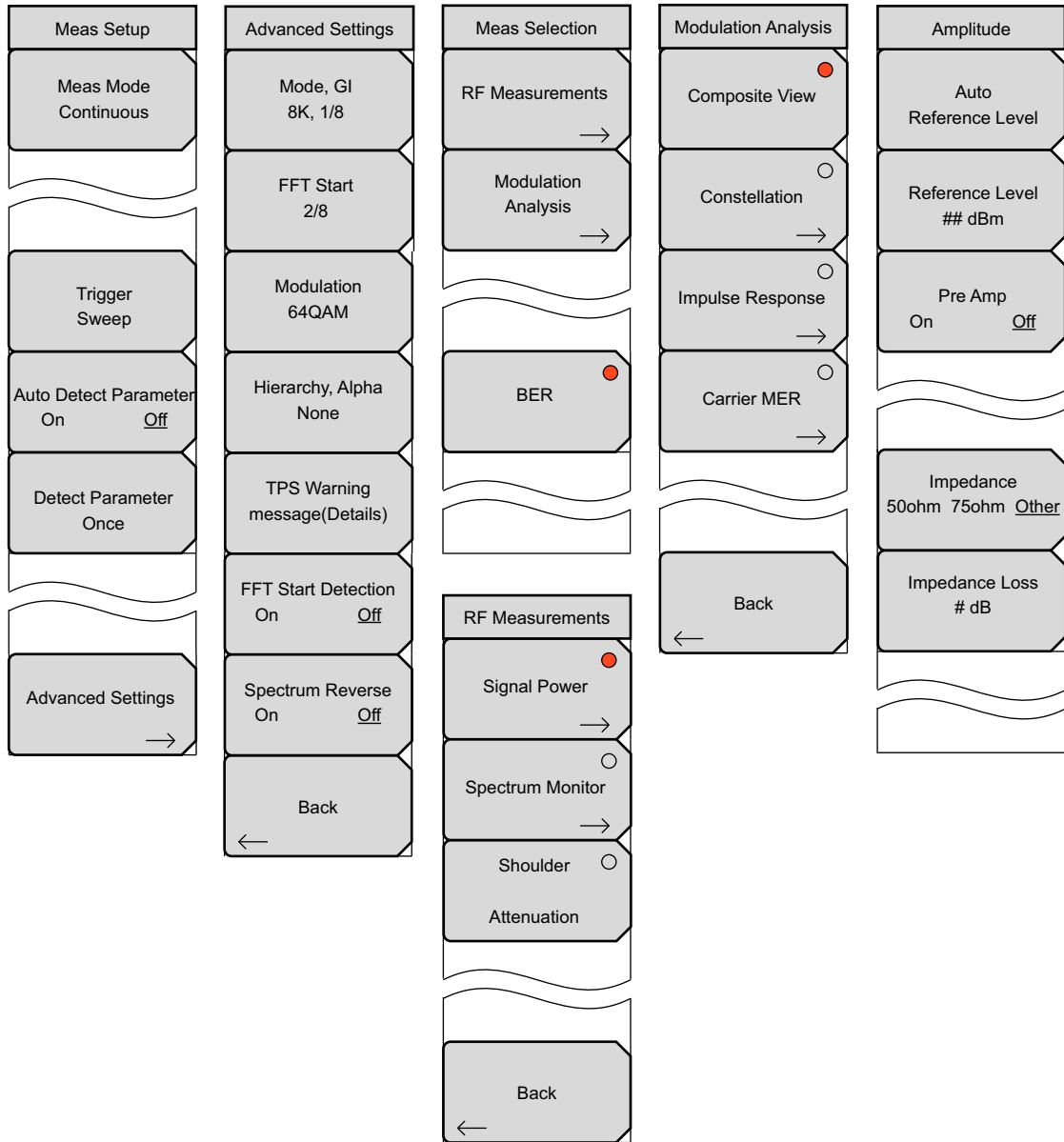


Figure 2-15. Measurement Setup and Selection Menus

Auto Detect Parameter is useful only when used in Continuous measurement mode. This automatic parameter detection function can be used in RF Measurements (Signal Power and Spectrum Monitor) and Modulation Analysis measurements. The Auto Detect Parameter feature does not perform the detection, but it triggers the Auto Reference Level function (available in the Amplitude menu) or the Detect Parameter Once function, or both, when the need arises.

In [Figure 2-15](#), the Meas Mode is set to Continuous. The Meas Setup and Advanced Settings menus in this figure apply only to RF Measurements and Modulation Analysis measurements, not to BER measurements.

BER Measurements:

Auto Detect Parameter and Detect Parameter Once are not available for BER measurements.

RF Measurements:

In RF Measurements measurement mode, the Auto Detect Parameter feature is seeking power level. The Auto Detect Parameter feature triggers the Auto Reference Level function (available in the Amplitude menu) when the need arises. If attempts to achieve optimal reference levels fail twice, then the Auto Detect Parameter feature is automatically turned off. Otherwise, the Auto Detect Parameter feature remains On and triggers the Auto Reference Level feature only when needed.

Modulation Analysis Measurements:

In Modulation Analysis measurement mode, the Auto Detect Parameter feature is seeking Mode, GI, Modulation, Hierarchy parameters, and Reference Level in multiple sweeps. If none of these parameters are detected, then the search ends, and the Auto Detect Parameter feature is automatically turned off. The Auto Detect Parameter feature automatically changes instrument settings for these parameters and triggers the Auto Reference Level feature (available in the Amplitude menu) or the Detect Parameter Once function, or both, when the need arises. If all of the parameter settings cannot be determined, or if parameter detection fails twice, or if attempts to achieve optimal reference levels fail twice, then the Auto Detect Parameter feature is automatically turned Off.

If Auto Detect Parameter is Off, then you can press the Detect Parameter Once submenu key to detect the same measurement parameters that would be detected by the Auto Detect Parameter feature if it were On.

While the Auto Detect Parameter function is seeking the correct signal parameters, it changes the settings. If unsuccessful, it tries again. If not successful after 2 tries, it is automatically turned Off. When the Auto Detect Parameter function fails and is automatically turned off, any of the parameter settings may then be different from their settings before using the Auto Detect Parameter function.

The Auto Detect Parameter feature also applies to Carrier MER measurements.

Parameter Detection for FFT Start:

The Auto Detect Parameter and Detect Parameter Once functions detect and set the FFT Start position only if the FFT Start Detection submenu key is set to On. The instrument searches for the best possible FFT Start position, which yields the highest MER result. Measurement begins after FFT Start is detected. This function is not valid when the FFT Start is set to a fixed position. Refer to [“FFT Start” on page 2-4](#).

When the FFT Start Detection submenu key is set to Off, the detect parameter operation does not search for FFT Start, but it does search for the other parameters. If you do not have a need to determine the FFT Start position manually, then the use of FFT Start Detection is recommended because it saves significant time.

2-7 General Measurement Setups

Refer to your instrument User Guide for directions about selecting the DVB Signal Analyzer mode.

2-8 Antenna Setup

The antenna attaches to the instrument with a coaxial cable. The antenna and coaxial cable are not supplied with the instrument and must be procured separately.

The antenna factors are different for each antenna. Refer to the documentation for your antenna. Also, remember to add the cable loss to the measurement correction table. You can use Master Software Tools (MST) to update your antenna and coaxial cable lists. For directions about updating these lists, refer to the Master Software Tools documentation (available from www.anritsu.com).

1. Attach the antenna to the Spectrum Analyzer connector on top of the instrument (refer to your instrument User Guide).

Select the Antenna as Follows:

2. Press the **Measurements** main menu key to open the Meas Selection menu.
3. Press the RF Measurements submenu key to open the RF Measurements menu.
4. Press the Signal Power submenu key. The Signal Power submenu key displays a red circle. Press the Signal Power submenu key again to open the Signal Power menu.
5. Press the Antenna (Correction Level) submenu key to display the Select Antenna list box.
6. In the Select Antenna list box, scroll to the desired Anritsu antenna model number by using the **Up/Down** arrow keys or the rotary knob, and press the rotary knob or the **Enter** key to select the antenna.

2-9 Setting up the Measurement Frequency

The measurement frequency can be set by entering the center frequency or by selecting the applicable signal standard and channel, which allows the instrument to automatically set the frequency.

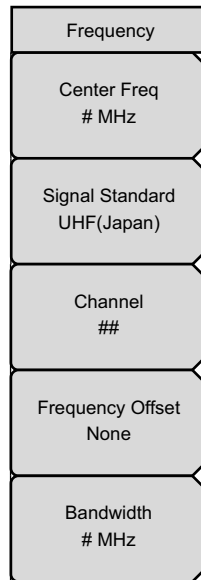


Figure 2-16. Frequency Menu

To Set Measurement Frequency by Entering Center Frequency

1. Press the **Frequency** main menu key to display the Frequency Menu ([Figure 2-16](#)).
2. Press the **Center Freq** submenu key to open the Frequency Editor dialog box.
3. Enter the required frequency by using the **Up/Down** arrow keys or the rotary knob, then press the **Enter** key. You may also use the keypad to enter a frequency.

When entering a frequency by using the keypad, the Frequency menu changes temporarily to a Units menu with submenu keys for GHz, MHz, kHz, and Hz. Press the appropriate units key. Pressing the **Enter** key has the same effect as pressing the MHz submenu key.

The current setting is shown at the top of the instrument settings summary column on the left side of the measurement screen.

To Set Measurement Frequency by Selecting a Signal Standard

1. Press the **Frequency** main menu key.
2. Press the **Signal Standard** submenu key to open the Signal Standards list box. Select the desired signal standard by using the **Up/Down** arrow keys or the rotary knob, then press the **Enter** key.

When a signal standard is selected, the center frequency is automatically tuned for the channel of the selected standard.
3. Press the **Channel** submenu key to open the Channel Editor dialog box and set the channel within the specified range.
4. If necessary, press the **Frequency Offset** submenu key to open the Select Frequency Offset dialog box. Set the channel frequency offset by using a value from the dialog box.

2-10 Bandwidth Setup

In the Frequency menu, press the **Bandwidth** submenu key to open the Select Band Width list box. Select an available bandwidth: 5 MHz, 6 MHz, 7 MHz, or 8 MHz. The selected bandwidth (BW) is displayed in the instrument settings summary column.

2-11 Amplitude Setup

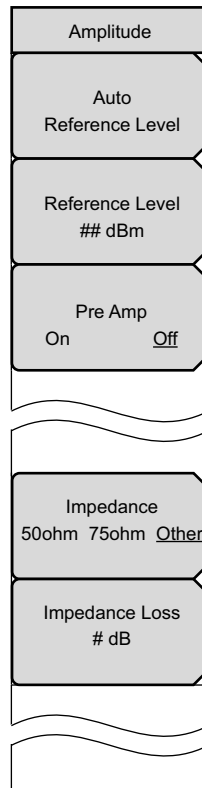


Figure 2-17. Amplitude Menu

1. Press the **Amplitude** main menu key to display the Amplitude menu ([Figure 2-17](#)).
2. Set the reference level automatically or manually.
 - a. **Auto:** Press the **Auto Reference Level** submenu key to allow the instrument to set an optimum reference level.
 - b. **Manual:** Press the **Reference Level** submenu key to open the Reference Level Editor dialog box and set the reference level. The range and increments of change are displayed in the dialog box.
3. Press the **Pre Amp** submenu key to toggle this function On and Off. The current state is underlined on the submenu key.
4. Press the **Impedance** submenu key to toggle through to the desired impedance parameter: 50 ohm, 75 ohm, or Other. If you select Other, then the **Impedance Loss** submenu key is displayed.
5. Press the **Impedance Loss** sub menu key to open the Impedance Loss Editor dialog box and select a dB loss level within the displayed range.

2-12 Quick Measurement Setup

1. Press the **Setup** main menu key to open the Meas Setup menu (Figure 2-18). These menus are not available when using the BER measurement option (refer to “DVB-T/H BER Measurements (Option 57 only)” on page 2-37 and Figure 2-31, “DVB-T/H BER Measurements Menu Group (Option 57 Only)” on page 2-43).

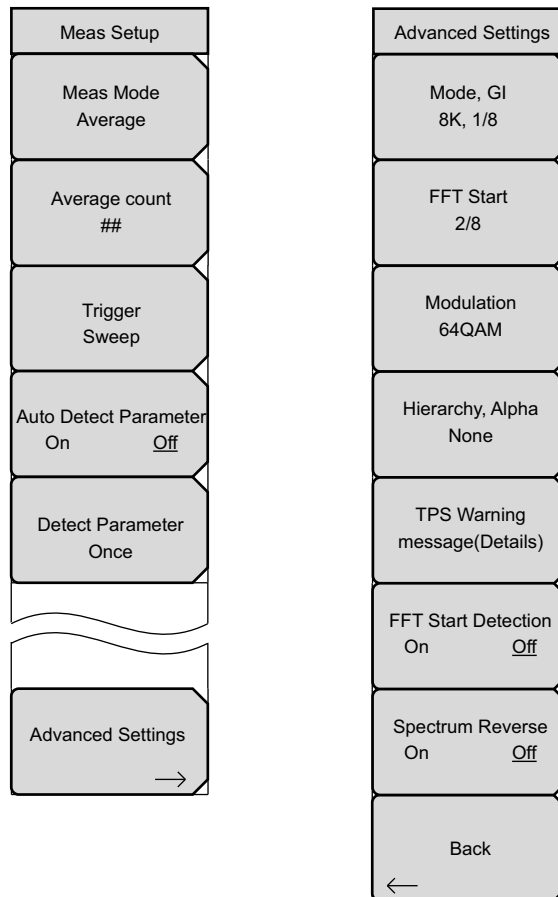


Figure 2-18. Measurement Setup Menu

2. Press the Meas Mode submenu key to open the Select Meas Mode dialog box and choose from: Single, Continuous, Average, Moving Average, or Max Hold. Refer to “Meas Mode Settings” on page 2-49.
 - a. The Average Count submenu key is displayed only if you select Average or Moving Average.
 - b. Press the Average Count submenu key to open the Average Count Editor dialog box. Select a count number within the displayed range and then press the **Enter** key.
3. Press the Auto Detect Parameter submenu key to toggle the setting to On.

4. Press the **Trigger Sweep** submenu key to initiate multiple sweeps searching for specific measurement parameters. Sweep types are set with the **Meas Mode** submenu key.

In **Modulation Analysis** measurement mode, the **Auto Detect Parameter** feature is seeking **Mode**, **GI**, **Modulation**, and **Hierarchy** parameters in multiple sweeps. If none of these parameters are detected, then the search ends, and the **Auto Detect Parameter** feature is automatically turned off.

In **RF Measurements** measurement mode, the **Auto Detect Parameter** feature is seeking **Power Level**, and it turns off automatically if detection fails.

5. If **Auto Detect Parameter** is **Off**, then press the **Detect Parameter Once** submenu key to detect specific measurement parameters.

The **Detect Parameter Once** submenu key causes the same general type of inquiry as the **Auto Detect Parameter** function, but only one try at a time.

Note The **Auto Detect Parameter** function and the **Detect Parameter Once** function may vary depending upon both the **Meas Mode** setting and the **Measurements** setting.

6. Press the **Advance Settings** submenu key to continue measurement setups.
7. Press the **Mode, GI** submenu key to select the desired lengths of the guard interval.

Table 2-1. Guard Interval Lengths in Microseconds

Length	2K	4K	8K
1/4	56 μ s	112 μ s	224 μ s
1/8	28 μ s	56 μ s	112 μ s
1/16	14 μ s	28 μ s	56 μ s
1/32	7 μ s	14 μ s	28 μ s

8. Press the **FFT Start** submenu key to open the **Select FFT Start** list box and select the desired start position with a guard interval (0/8 indicates no guard interval).
9. Press the **Modulation** submenu key to open the **Select Modulation** list box and choose the desired modulation type: **QPSK**, **16QAM**, or **64QAM**.
10. Press the **Hierarchy, Alpha** submenu key to open the **Select Hierarchy, Alpha** list box and choose: **None**, **1**, **2**, or **4**.
11. Press the **TPS warning message (Details)** submenu key to display any available warning messages.
12. Press the **FFT Start Detection** submenu key to toggle detection **On** or **Off**. The current state is underlined on the submenu key.

Set detection to On in order to continuously search for the FFT Start position from the input signal. This function is not valid when the FFT Start setup value is Fixed. Measurement begins after FFT Start is detected.

13. Press the Spectrum Reverse submenu key to toggle between On and Off. Use Spectrum Reverse to measure a signal with the subcarrier location inverted on the frequency axis, such as the IF signal of the transmitter.

2-13 DVB-T/H RF Measurements

Signal Power, Spectrum Monitor, and Shoulder Attenuation are measurements in the RF Measurement mode.

Signal Power

1. Press the **Measurements** main menu key to open the Meas Selection menu.
2. Press the RF Measurements submenu key to open the RF Measurements menu.
3. Press the Signal Power submenu key to activate the measurement. The sample image in [Figure 2-19](#) may differ from the actual screen on your instrument.
4. Press the Signal Power submenu key again to open the Signal Power menu.
5. Press the Antenna (Correction Level) submenu key to open the Select Antenna list box. Scroll with the **Up/Down** arrow keys or the rotary knob to highlight an antenna, and then select by pressing **Enter**. Note that pressing the **Left/Right** arrow keys moves the highlighted selection to the top or bottom of the list for quicker navigation.

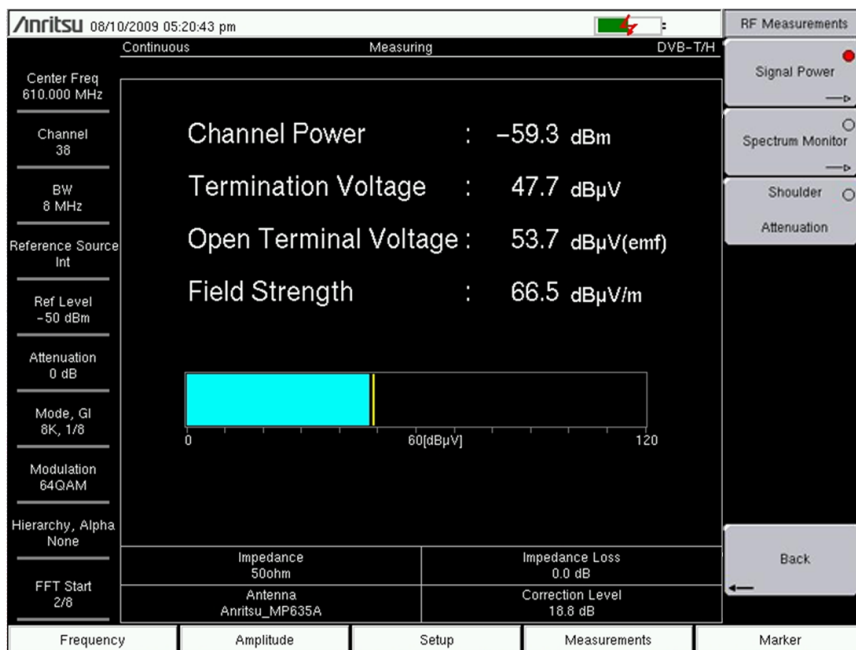


Figure 2-19. Signal Power Measurement Screen

6. Press the Back submenu key to return to the RF Measurements menu.

7. Press the Back submenu key again to return to the Meas Selection menu.

Spectrum Monitor

This measurement displays the frequency response around the desired channel. The variable span supports display of up to 51 channels simultaneously, so that the broadcast service signals can be checked at a glance.

1. Press the **Measurements** main menu key to open the Meas Selection menu.
2. Press the RF Measurements submenu key to open the RF Measurements menu.
3. Press the Spectrum Monitor submenu key to activate the measurement. The sample image in [Figure 2-20](#) may differ from the actual screen on your instrument.
4. Press the Spectrum Monitor submenu key again to open the Spectrum Monitor menu.
5. From the Spectrum Monitor menu, press the **Span** submenu key to open the Select Span list box and select the number of channels to span in the measurement display. Choose from: 1CH, 3CH, 5CH, 11CH, 31CH, and 51CH.
 - a. Use the **Left/Right** arrow keys to move the green zone marker from channel to channel across the measurement display.
 - b. Use the **Up/Down** arrow keys to cycle through the span settings, whereby each press of the **Up** arrow displays more channels, and each press of the **Down** arrow displays less channels (in the increments that are described for the **Span** submenu key in [Step 5](#)).

Note

The **Up/Down** arrow keys provide a zoom-in and zoom-out function for displaying the number of channels (similar to using the **Span** submenu key).

If the green zone marker is marking a channel that is not centered in the sweep window, then using the **Up** arrow key to zoom out leaves the zone marker on the same channel, but using the **Down** arrow to zoom in on the number of displayed channels will shift the zone marker to the center of the measurement display when the marked channel goes off-screen.

- Press the Zone Position to Center submenu key to move the currently marked channel (within the green zone marker) to the center of the measurement display (the center of the sweep window).

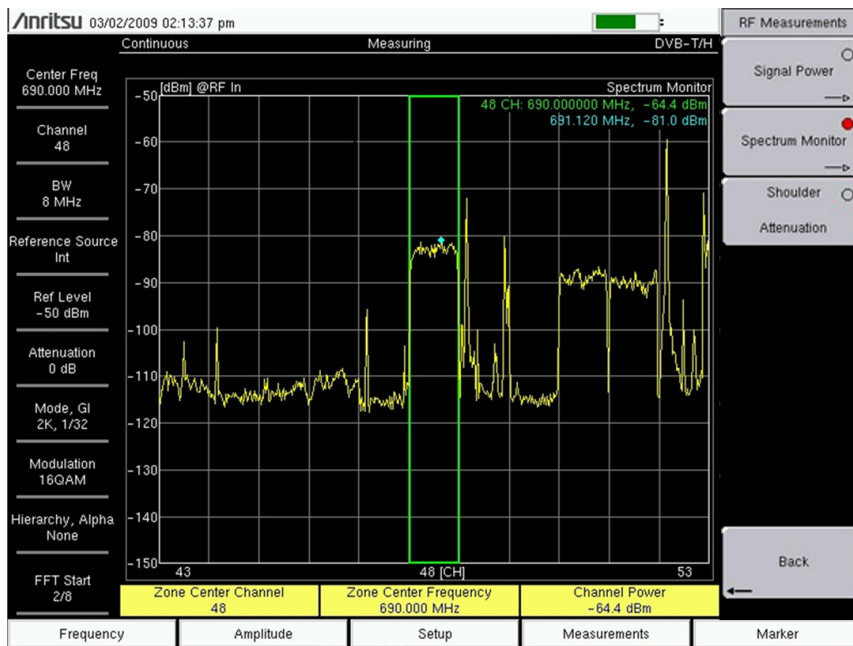


Figure 2-20. Spectrum Monitor Measurement Screen

A blue diamond-shaped marker (within the green zone markers) indicates frequency and level information of the peak value within the channel. This is an automatic function that has no user controls.

Shoulder Attenuation

The Shoulder Attenuation measurement can be used to characterise the linearity of an OFDM signal without reference to a spectrum mask. It is performed while directly connected to the output of a transmitter via an attenuator or to a decoupled test point.

Measurement Setup:

1. Press the **Measurements** main menu key to open the Meas Selection menu.
2. Press the RF Measurements submenu key to open the RF Measurements menu.
3. Press the Shoulder Attenuation submenu key to activate that measurement. The sample image in [Figure 2-21](#) may differ from the actual screen on your instrument.

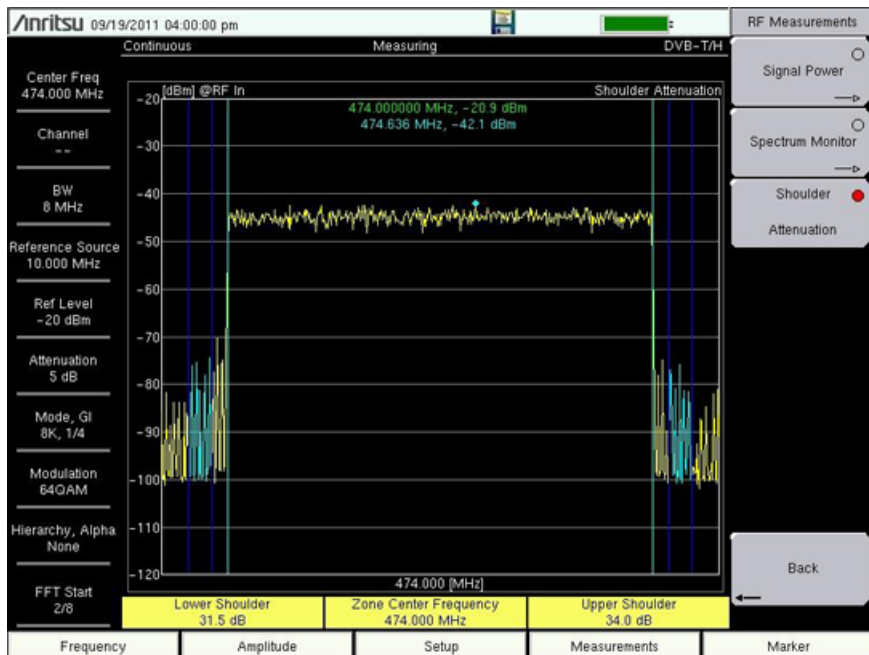


Figure 2-21. Shoulder Attenuation Measurement Screen

4. Press the Back submenu key to return to the RF Measurements menu.
5. Press the Back submenu key again to return to the Meas Selection menu.

2-14 DVB-T/H Modulation Measurements

Constellation, Impulse Response, and Carrier MER are measurements in the Modulation Analysis mode.

Composite View

The composite view includes four graphs: Data & TPS (Constellation), Impulse Response (All), Carrier MER, and Frequency Response.

1. Press the **Measurements** main menu key to display the Meas Selection menu.
2. Press the **Modulation Analysis** submenu key to open the Modulation Analysis menu.
3. Press the **Composite View** submenu key to simultaneously view 4 measurement graphs on the instrument screen. The sample images in [Figure 2-22](#) and [Figure 2-23](#) may differ from the actual screens on your instrument.

Below the measurement graphs, a measurement table provides specific measurement information, which includes: frequency offset, channel power, and MER (Modulation Error Ratio). This table is also displayed below each of the individual Modulation Analysis measurement displays. The table data is displayed even if the graphic display does not include the associated measurement data, as in [Figure 2-23](#), which displays MER data in the table but does not display graphic Carrier MER data.

The constellation grid values and spacing depend upon the modulation and hierarchy (alpha) settings. For more information, refer to section "[Hierarchical Modulation](#)" on page 2-5.

4. Press the **Back** submenu key to return to the Meas Selection menu.

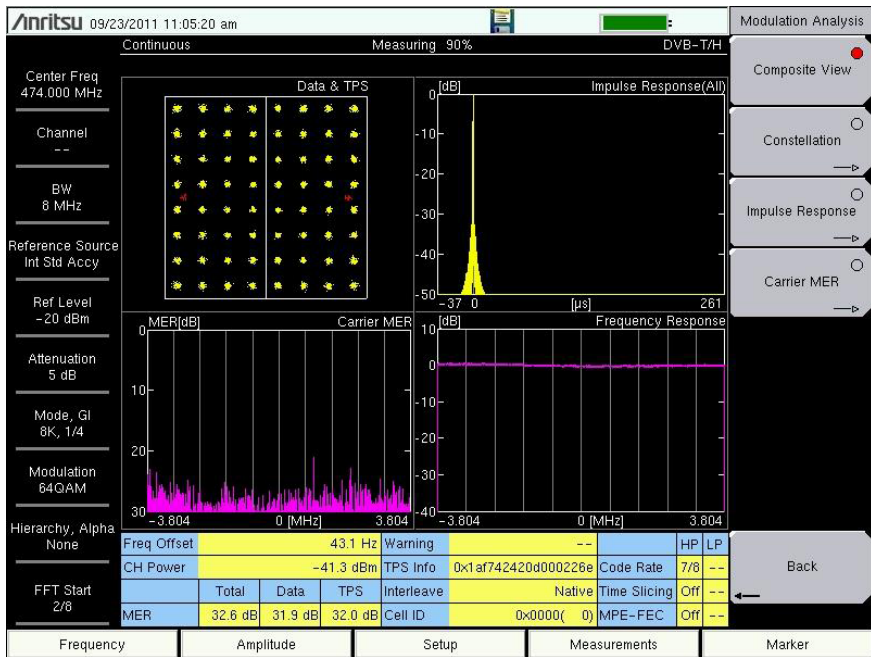


Figure 2-22. Modulation Analysis, Composite View

Constellation

The Constellation measurement display is labeled DATA & TPS. The measurement table (as described in [Step 3](#) of “Composite View” on page 2-30) is displayed below the constellation graph. The sample Constellation measurement image in [Figure 2-23](#) may differ from the actual screen on your instrument.

1. Press the **Measurements** main menu key to display the Meas Selection menu.
2. Press the Modulation Analysis submenu key to open the Modulation Analysis menu.
3. Press the Constellation submenu key to view the Data & TPS (Constellation) measurement graph. The sample image in [Figure 2-23](#) may differ from the actual screen on your instrument.
4. Press the Constellation submenu key again to open the Constellation menu to set up Graph Annotation.
5. Press the Graph Annotation submenu key to toggle annotation On or Off. The current setting is underlined on the submenu key. When annotation is On, grid lines are displayed in the constellation graph.
6. Press the Back submenu key to return to the Modulation Analysis menu.

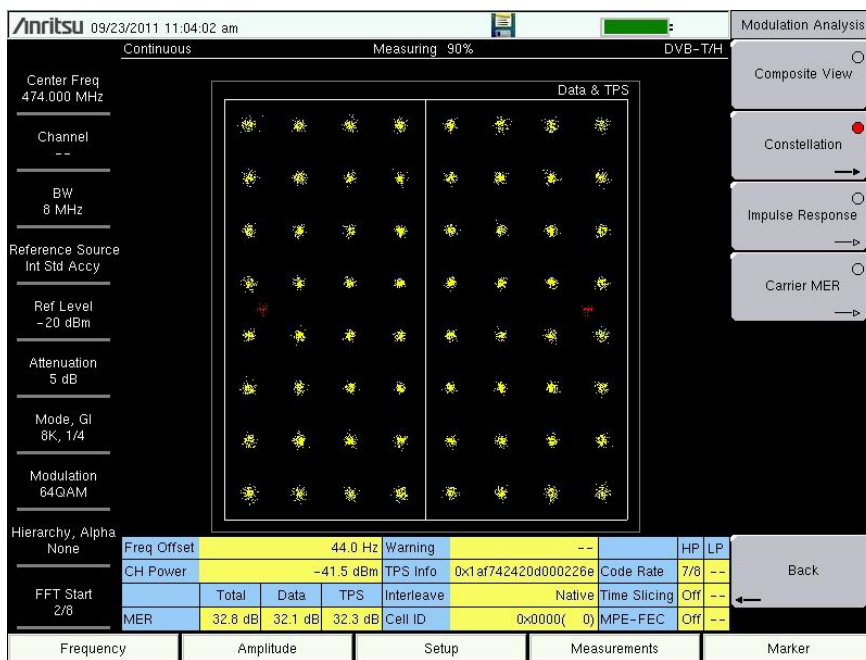


Figure 2-23. Modulation Analysis, Constellation View without Graph Annotation

Impulse Response

The Impulse Response views, Impulse Response (All) and Impulse Response (Zoom), are displayed one above the other. The measurement table (as described in [Step 3 of “Composite View” on page 2-30](#)) is displayed below the Impulse Response graphs. The sample images in [Figure 2-24](#) and [Figure 2-25](#) may differ from the actual screens on your instrument.

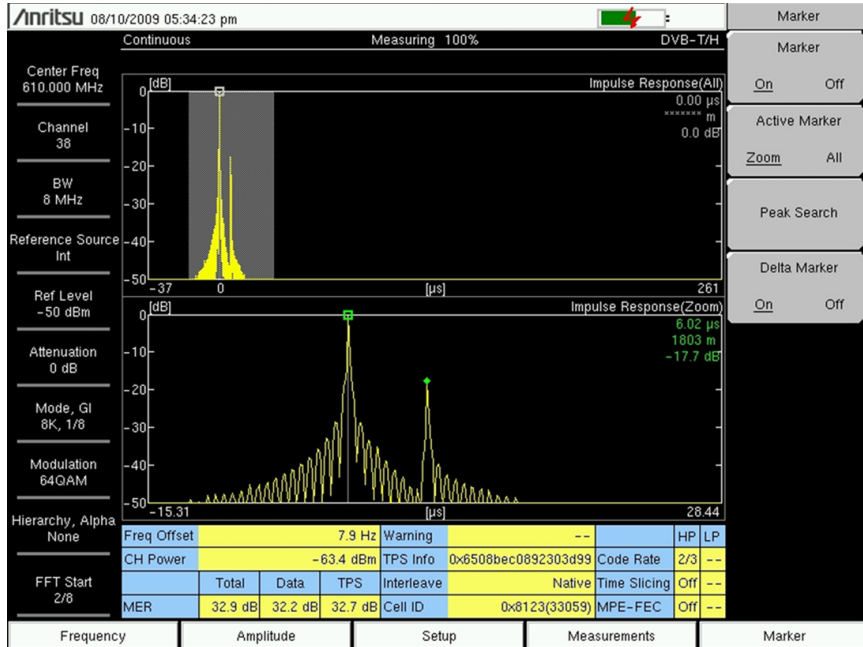


Figure 2-24. Modulation Analysis, Impulse Response View, Delta Marker ON

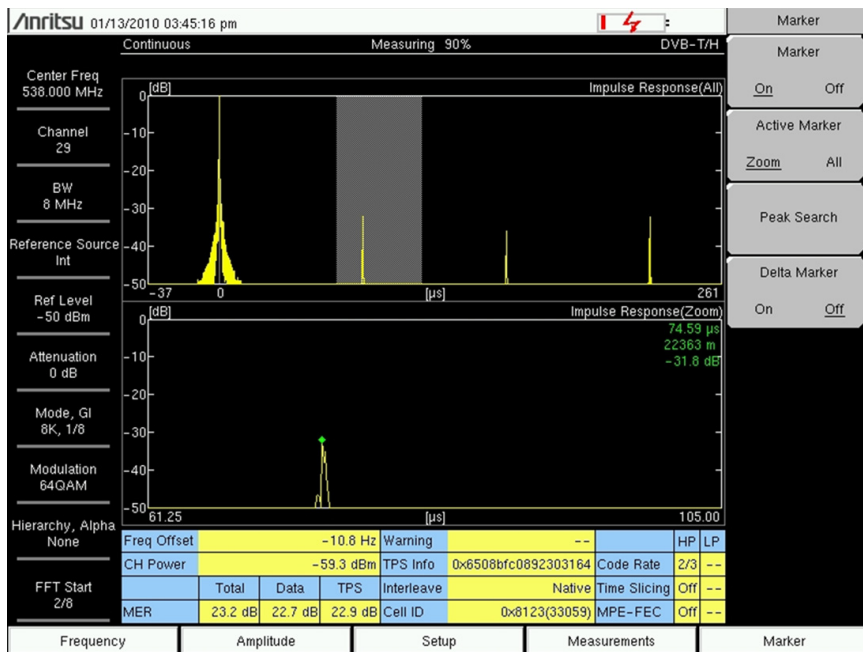


Figure 2-25. Modulation Analysis, Impulse Response View, Delta Marker OFF

1. Press the **Measurements** main menu key to display the Meas Selection menu.
2. Press the Modulation Analysis submenu key to open the Modulation Analysis menu.
3. Press the Impulse Response submenu key to display the Impulse Response (All) and Impulse Response (Zoom) graphs.
4. Press the Impulse Response submenu key again to open the Impulse Response menu in order to set up 0 μ s Position, Path_Posn_Keep, and Vertical Range.
 - a. Press the 0 μ s Position submenu key to open the Select 0 μ s Position list box. Select the desired position (Left, Center, Right) and then press **Enter**.
 - b. Press the Path_Posn_Keep submenu key to toggle the setting On or Off. The current setting is underlined on the submenu key. When the path position keep setting is On, the main and delayed signals are locked in place.
 - c. Press the Vertical Range submenu key to open the Vertical Range menu. Press one of the four submenu keys (5 dB, 10 dB, 25 dB, or 50 dB) to set the y-axis of the Impulse Response graphs.
 - d. Press the Back submenu key to return to the Impulse Response menu.

5. Press the Back submenu key again to return to the Modulation Analysis menu.

Table 2-2. Impulse Response Vertical Range

Vertical Range	Value (dB)
5 dB	0 dB to -5 dB
10 dB	0 dB to -10 dB
25 dB	0 dB to -25 dB
50 dB	0 dB to -50 dB

Carrier MER

The Carrier MER view displays two graphs: Carrier MER (All) and Carrier MER (Zoom). The measurement table (as described in Step 3 of “Composite View” on page 2-30) is displayed below the Carrier MER graphs. Refer to Figure 2-26, which may differ from the actual screen on your instrument.

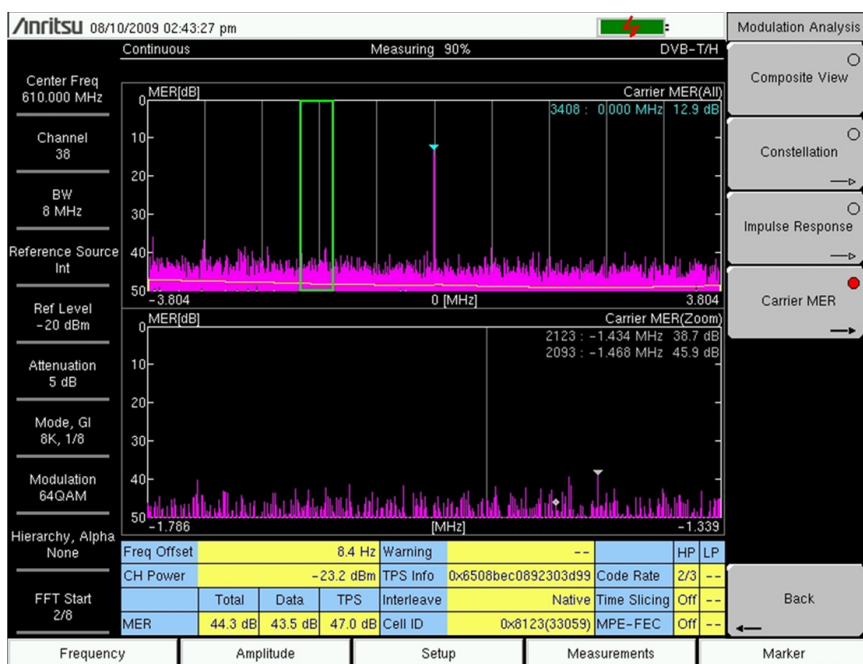


Figure 2-26. Carrier MER

1. Press the **Measurements** main menu key to display the Meas Selection menu.
2. Press the Modulation Analysis submenu key to open the Modulation Analysis menu.
3. Press the Carrier MER submenu key to view the Carrier MER (All) and Carrier MER (Zoom) graphs.
4. Press the Carrier MER submenu key again to open the Carrier MER menu in order to set up a vertical range and the measurement type (Speed or Accuracy).

- a. Press the **Vertical Range** submenu key to open the Vertical Range menu. Press one of the four submenu keys (20 dB, 30 dB, 40 dB, or 50 dB) to set the y-axis of the Carrier MER graphs.
 - b. Press the **Back** submenu key to return to the Carrier MER menu.
 - c. Press the **Measurement Type** submenu key to toggle the setting to either **Speed** or **Accuracy**. The current setting is underlined on the submenu key.
5. Press the **Back** submenu key to return to the Modulation Analysis menu.

Table 2-3. Carrier MER Vertical Range

Vertical Range	Value (dB)
20 dB	0 dB to 20 dB
30 dB	0 dB to 30 dB
40 dB	0 dB to 40 dB
50 dB	0 dB to 50 dB

2-15 DVB-T/H BER Measurements (Option 57 only)

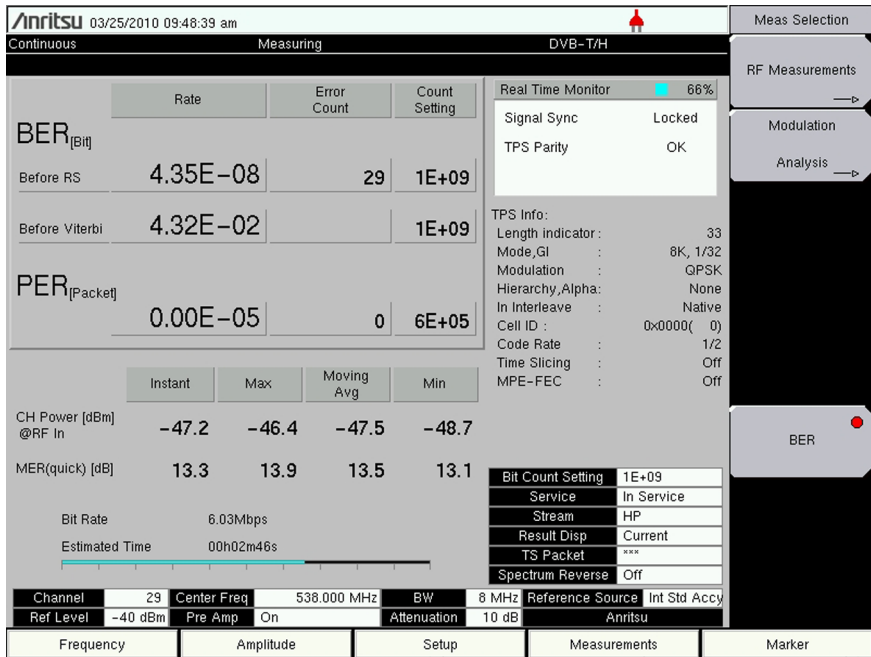


Figure 2-27. Bit Error Rate (BER) Measurements

DVB ASI Out Connector

The digital signal output, 50 Ω Type-N female connector (shown in [Figure 1-1 on page 1-3](#)) is present only when both DVB-T/H (Option 64 or Option MS8911B-0050) and DVB-T/H BER (Option 57) are installed on your instrument.

The DVB-ASI function produces MPEG-TS data output during a BER measurement. This output can be connected to MPEG-TS analysis equipment to monitor video errors or can be connected via an appropriate ASI to USB demultiplexing and decoding accessories for channel identification and monitoring purposes.

Note You can monitor this port to verify that you are connected to the correct input channel.

Figure 2-27 is a sample BER measurement to show the types and locations of data that are displayed. This image may differ from the actual screen on your instrument. The following procedure describes an example BER measurement.

1. Press the **Measurements** main menu key to display the Meas Selection menu.
2. Press the BER submenu key to view the BER measurement screen.

Note

The **BER Meas Point**, submenu key is displayed ONLY when the **Service** submenu key is set to **Out of Service**. Refer to the following [Step 3c](#). Refer also to submenu key “**BER Meas Point**” in [Section 2-33 “BER Setup \(1/2\) Menu \(Option 57 Only\)”](#) on page 2-59.

3. Press the **Setup** main menu key to open the Meas Setup (1/2) menu and configure the following parameters: Meas Mode, Bit Count Setting, Service, Stream, BER Meas Point, and Result Disp.
 - a. Press the **Meas Mode** submenu key to open the Select Meas Mode list box and choose either Single or Continuous. Refer to “[Meas Mode Settings](#)” on page 2-49.
 - b. Press the **Bit Count Setting** submenu key to open the Bit Count Setting Editor dialog box.
 - 1) Press the **Mantissa** submenu key to set the desired Mantissa.
 - 2) Press the **Exponent** submenu key to set the desired Exponent value.
 - 3) Press **Enter** to set the new Mantissa and Exponent. The menu returns to Meas Setup (1/2).
For an example of the Bit Count Setting for mantissa and exponent, refer to [Table 2-4 on page 2-39](#).
 - c. Press the **Service** submenu key to open the Select Service list box. Choose between In Service testing and Out of Service testing and then press **Enter**. Continue at the following [Step 1](#) if Out of Service testing is selected. Continue at [Step 3d](#) if In Service testing is selected.
 - 1) If Out of Service is selected, then the BER Meas Point submenu key is displayed in the Meas Setup (1/2) menu list, and the TS Packet submenu key is displayed in the Meas Setup (2/2) menu list.
 - 2) Press the BER Meas Point submenu key to open the Select BER Meas Point list box. Use the arrow keys or the rotary knob to highlight the desired parameter (Before Viterbi, Before RS, or After RS) and then press **Enter**.
 - 3) Press the **More** submenu key to display the Meas Setup (2/2) menu, and then press the TS Packet submenu key to open the Select TS Packet list box. Highlight the desired TS Packet value and press **Enter**.
 - 4) Press the **Spectrum Reverse** submenu key to toggle this view On or Off. The current setting is underlined on the submenu key.
 - 5) Press the **TPS warning** submenu key to display any available warning messages.
 - 6) Press the **Back** submenu key to return to the Meas Setup (1/2) menu.

- d. Press the **Stream** submenu key to open the Select Stream list box. Highlight HP (High Priority) or LP (Low Priority) and then press **Enter**.
- e. Press the **Result Disp** submenu key to toggle between **Current** and **Last**. The current setting is underlined on the submenu key. Select **Current** to view the current measurement, or select **Last** to view the last measurement taken, and then press **Enter**.
- f. Press the **More** submenu key.
- g. Press the **Spectrum Reverse** submenu key to toggle this view **On** or **Off**. The current setting is underlined on the submenu key.
- h. Press the **TPS warning** submenu key to display any available warning messages.
- i. Press the **Back** submenu key to return to the Meas Setup (1/2) menu.

Table 2-4. BER Setup Parameters Table

Bit Count Setting	3E+07
Service	Out Of Service
Stream	HP
Result Disp	Current
TS Packet	1+[187]+16
Spectrum Reverse	On

2-16 DVB-T/H Menus

In some Anritsu manuals, **main menu keys** may also be called **hard keys**, and submenu keys may also be called **soft keys**.

Main Menu Group

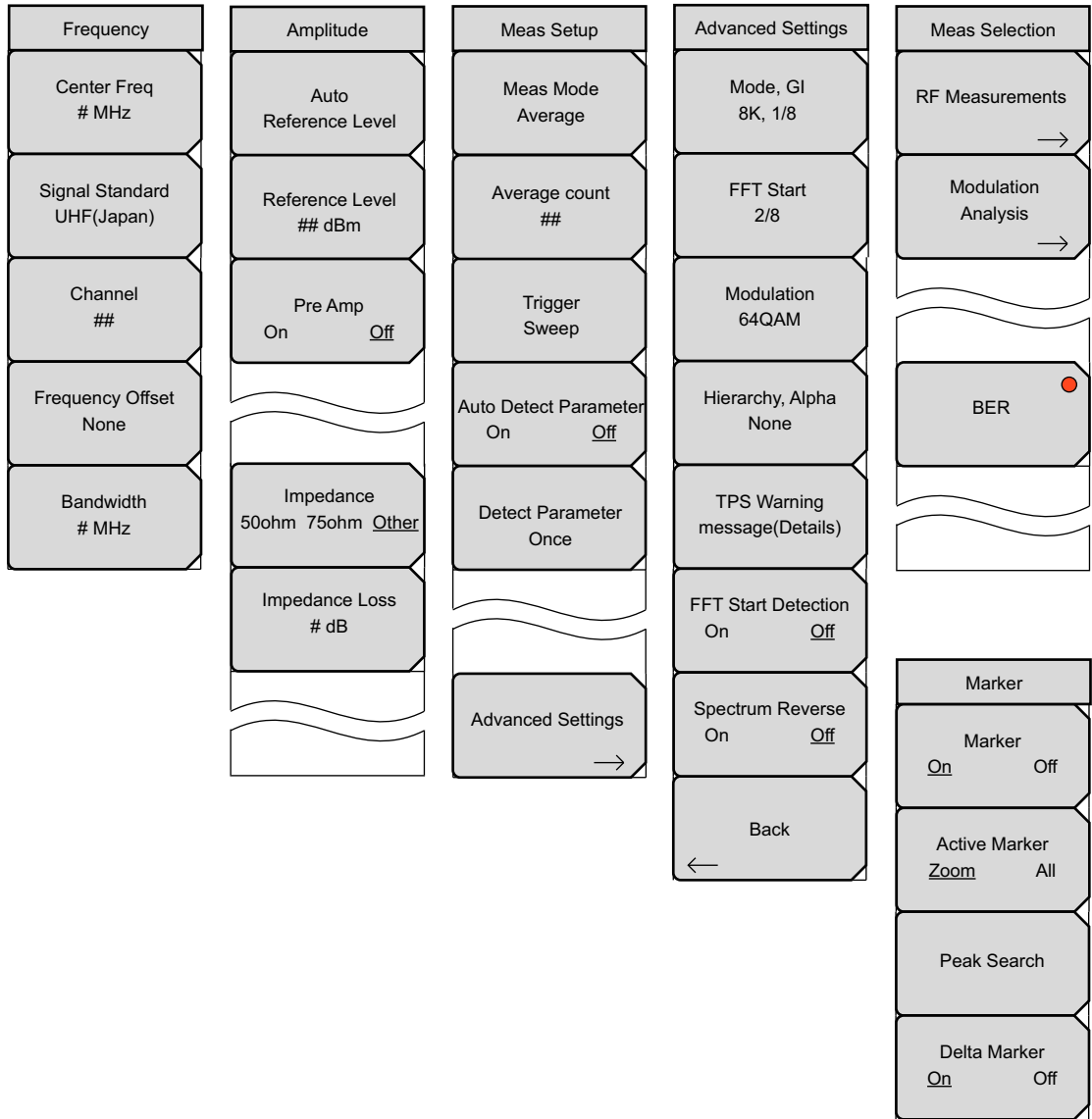


Figure 2-28. DVB-T/H Main Menu Group

RF Measurement Menu Group

Note that the BER submenu key is displayed and available only when Option 57 is installed.

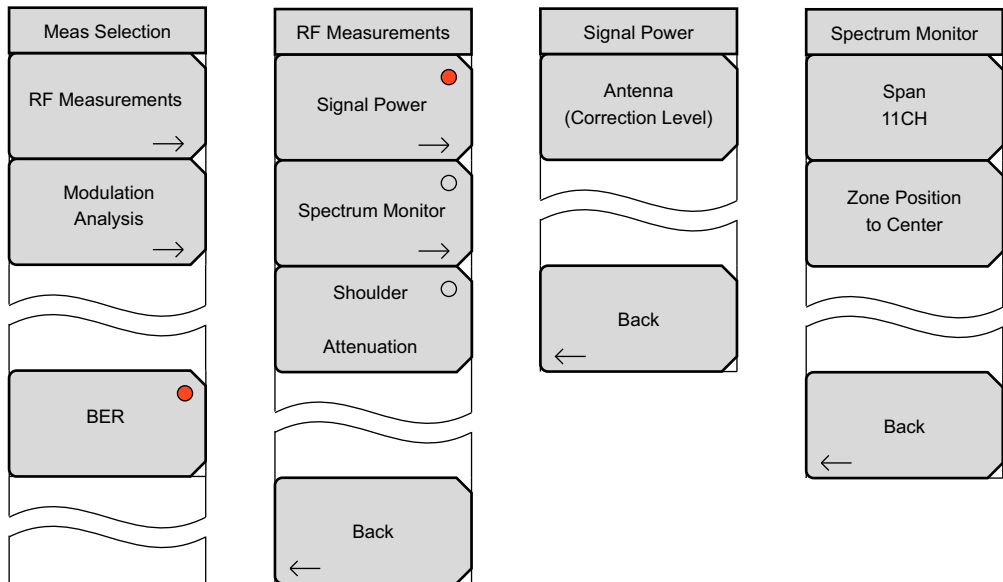


Figure 2-29. DVB-T/H RF Measurements Menu Group

Modulation Analysis Menu Group

Note that the BER submenu key is displayed and available only when Option 57 is installed.

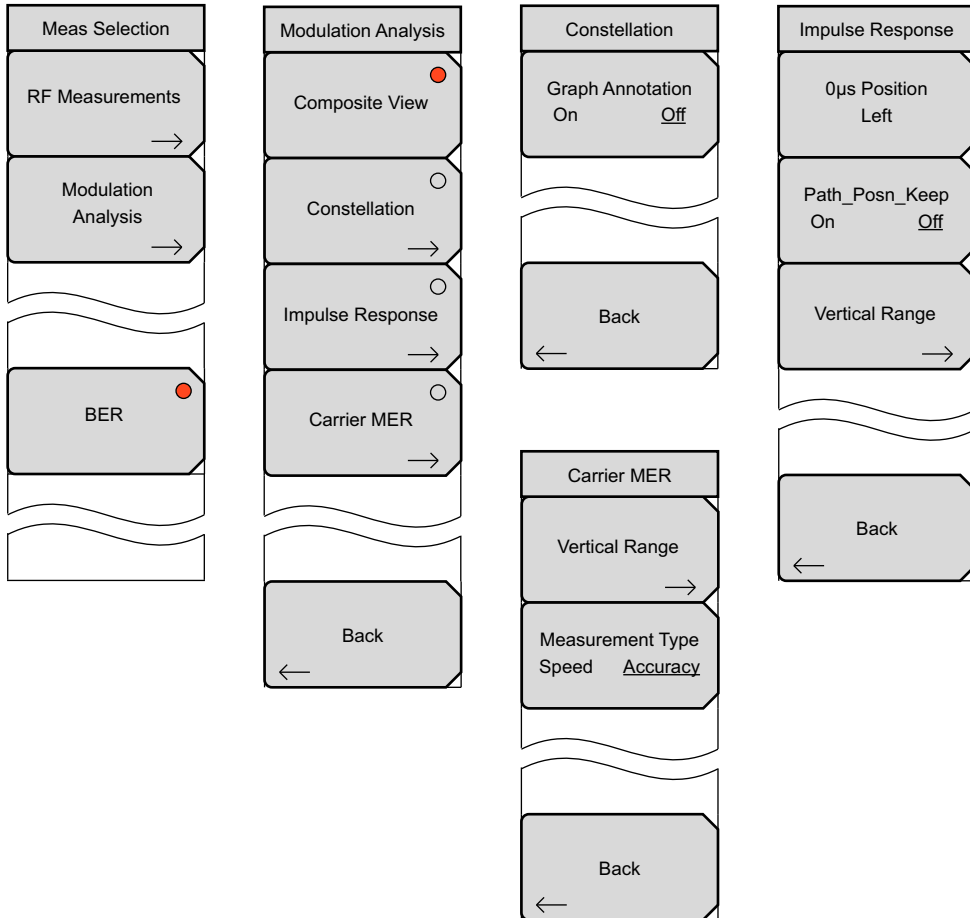


Figure 2-30. DVB-T/H Modulation Analysis Measurements Menu Group

BER Menu Group

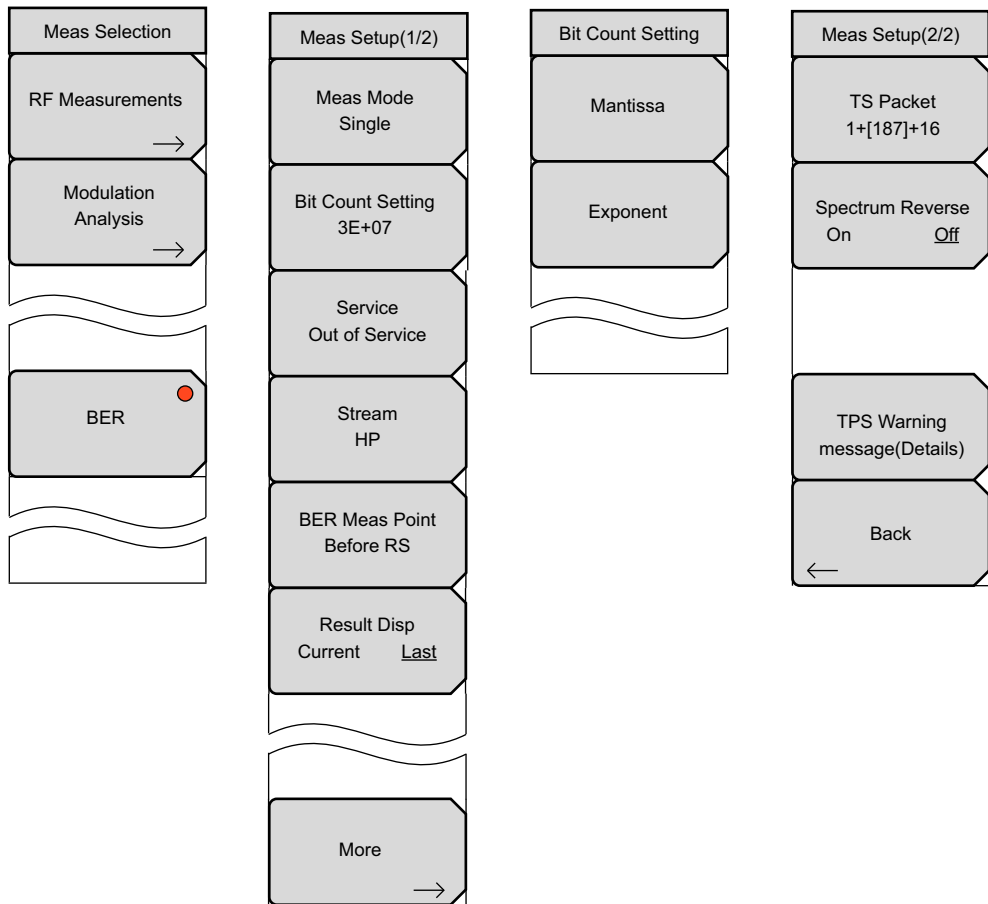


Figure 2-31. DVB-T/H BER Measurements Menu Group (Option 57 Only)

2-17 Frequency Menu

This menu is used to set the frequency for all DVB-T/H measurements. You can set up the measurement frequency by manually entering a center frequency (by using the **Center Freq** submenu key) or by selecting a signal standard (by using the **Signal Standard** submenu key).

Key Sequence: **Frequency**

Frequency	Center Freq: Press this submenu key to open the Frequency Editor dialog box to allow entering a center frequency. Range is from 30 MHz to 2800 MHz in 1 Hz steps.
Center Freq # MHz	Signal Standard: Press this submenu key to open the Signal Standards list box to allow channel map selections for Digital Terrestrial TV UHF(Japan), Digital Terrestrial TV UHF(Europe), Digital Terrestrial TV UHF(Australia), or None. Bandwidths are automatically set for each region: Japan: 6 MHz Europe: 7 MHz Europe: 8 MHz Australia: 7 MHz
Signal Standard UHF(Japan)	
Channel ##	Channel: Press this submenu key to open the Channel Editor dialog box in order to select a channel within a specified UHF region (that is subsequently displayed on the Signal Standard submenu key). The channel range for each country: Japan: channels 13 to 62 Europe: channels 5 to 12 Europe: channels 21 to 69 Australia: channels 28 to 69.
Frequency Offset None	Frequency Offset: Press this submenu key to open the Select Frequency Offset list box. Select None or one of the six offset frequencies: –499.999 kHz, –333.333 kHz, –166.666 kHz, None, 166.666 kHz, 333.333 kHz, 499.999 kHz.
Bandwidth # MHz	Bandwidth: Press this submenu key to open the Select Band Width list box and manually select a bandwidth: 5 MHz, 6 MHz, 7 MHz, or 8 MHz.

Figure 2-32. Frequency Menu

2-18 Signal Standard Menu

This menu is used to select a signal standard from the list, and to organize the list.

Key Sequence: **Frequency** > Signal Standard

Standard List	Display
Display All Fav	All Fav: Press this submenu key to toggle the Signal Standards list to display all of the signal standards or to display only your favorite signal standards, which you can select with the other keys in this menu.
Select/Deselect Favorite	Select/Deselect Favorites: Press this submenu key to mark (select) or unmark (deselect) a signal standard from the list that is displayed in the Signal Standards list (either the All View or the Favorites View). After marking, pressing the Display submenu key to toggle the list display causes any deselected standards to be hidden from the Favorites View list. they continue to show a mark (an asterisk *) in the All View list.
Save Favorites	Save Favorites: Press this submenu key to Save the current Favorites selection. The next time that the Signal Standards list is displayed, the marked favorites are remembered.
Top of List	Top of List: Press this submenu key to move the selection highlight to the top entry in the displayed Signal Standards list (All or Favorites).
Page Up	Page Up: Press this submenu key to scroll up by one page of signal standards in the displayed Signal Standards list.
Page Down	Page Down: Press this submenu key to scroll down by one page of signal standards in the displayed Signal Standards list.
Bottom of List	Bottom of List: Press this submenu key to move the selection highlight to the bottom entry in the displayed Signal Standards list (All or Favorites).

Figure 2-33. Signal Standard Menu

2-19 Amplitude Menu

This menu is used to set the amplitude for all DVB-T/H measurements.

Key Sequence: **Amplitude**

Amplitude	<p>Auto Reference Level: Press this submenu key to automatically set the reference level to an optimum value. This reference level indicates the signal level input to the instrument. The reference level range for signal input to the instrument is determined by the reference level setting. Immediately after a signal is applied to the instrument, the input attenuator is automatically set according to the reference level. The relationship between the reference level and the input attenuator is fixed. The power levels and offset levels for this relationship are listed in Table 2-5.</p>
Auto Reference Level	<p>Raising the reference level increases attenuation of the input attenuator, enabling the user to handle a high input level. Note that the noise floor rises in proportion to the attenuation of the input attenuator.</p>
Reference Level ## dBm	<p>When applying a signal to the instrument, input a signal level that does not exceed the reference level value. If the signal level exceeds the reference level, raise the reference level. For example, if the signal level is 0.5 dBm with preamplifier off, set the reference level to 5 dBm, not to 0 dBm.</p>
Pre Amp On Off	<p>If an interfering wave other than the intended signal exists and the power is 15 dB or more higher than the measurement signal level, set the reference level to take the large signal into account.</p>
Impedance 50ohm 75ohm Other	<p>Reference Level: Opens the Reference Level Editor dialog box in order to select a signal reference value within the specified range that is displayed in the window. If the Pre Amp submenu key indicates On, then the reference level range is from –10 dBm to –50 dBm in 10 dB increments. If the Pre Amp submenu key indicates Off, then the reference level range is from –25 dBm to 20 dBm in 5 dB increments. Refer to Table 2-5 for the reference level relationship to input attenuation and preamplifier setting.</p>
Impedance Loss # dB	<p>Pre Amp On Off: Press this submenu key to turn on or off the low-noise front-end preamplifier. To assure accurate measurement results, the largest signal into the instrument input when the preamplifier is turned on should be less than –40 dBm.</p>
	<p>Impedance 50 Ohm 75 Ohm Other: Press this submenu key to toggle the selection to 50 ohm, 75 ohm, or Other impedance value. Selecting 75 ohm selects the 7.5 dB loss of the Anritsu 12N50-75B adapter. For other adapters, select “Other” and enter the appropriate loss.</p>
	<p>Impedance Loss: This submenu key is displayed only when the Impedance submenu key is set to Other. Press this submenu key to open the Impedance Loss Editor dialog box and set a dB value.</p> <p>Set the impedance loss in the range of 0.0 dB to 100.0 dB (in 0.1 dB steps) when the impedance is set to Other (which is also 75 ohms). Set 1.9 dB when using the MA1621A impedance transformer as the impedance converter.</p>

Figure 2-34. Amplitude Menu

Reference Level, Input Attenuation, and Preamplifier Setting

Reference Level Relationship to Input Attenuation and Preamplifier Setting

Table 2-5. Fixed Relationship of Input Attenuator to Auto Reference Level

Preamplifier State	Reference Level	Input Attenuator
Off	20 dBm	45 dB
Off	15 dBm	40 dB
Off	10 dBm	35 dB
Off	5 dBm	30 dB
Off	0 dBm	25 dB
Off	-5 dBm	20 dB
Off	-10 dBm	15 dB
Off	-15 dBm	10 dB
Off	-20 dBm	5 dB
Off	-25 dBm	0 dB
On	-10 dBm	40 dB
On	-20 dBm	30 dB
On	-30 dBm	20 dB
On	-40 dBm	10 dB
On	-50 dBm	0 dB

2-20 Meas Setup Menu

This menu is used to set up the RF and Modulation Analysis measurement modes.

Key Sequence: **Setup**

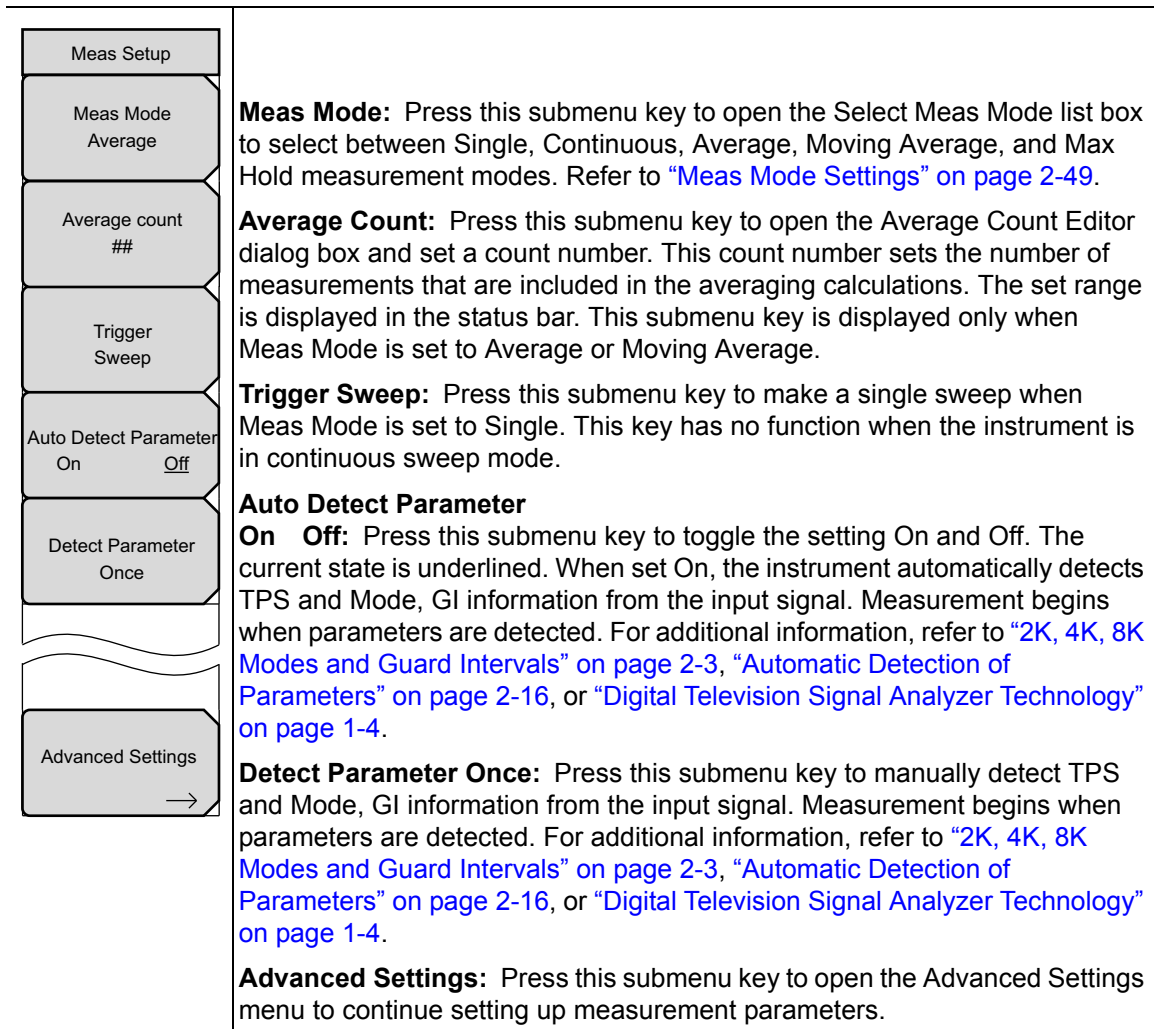


Figure 2-35. Meas Setup Menu

When the instrument is set to BER mode, pressing the Setup main menu key opens the BER setup menu. Refer to [Section 2-33 “BER Setup \(1/2\) Menu \(Option 57 Only\)”](#) on page 2-59.

Meas Mode Settings

Single: Sets up the test for one measurement. The instrument acquires the measurement and displays the results. This mode is useful for capturing screen images. Press the Trigger Sweep submenu key when ready to take a measurement.

Continuous: Sets up the test to take measurements continuously and display the results. The mode is helpful for real-time signal analysis.

Average: Sets up the test to mathematically average the measurement results for the specified number of measurements, as set with the Average Count submenu key.

Moving Average: Sets up the test to take the number of measurements that are set with the Average Count submenu key. An average result is calculated from those measurements and is displayed. Then another measurement is taken, and another average is calculated from the last number of measurements, as set in Average Count, and the display screen is updated. This mode is useful while aiming the antenna.

Example for Moving Average:

First $(m1 + m2 + m3 + m4 + m5) = r1$ (with r1 displayed on screen)

then $(m2 + m3 + m4 + m5 + m6) = r2$ (with r2 displayed on screen)

then $(m3 + m4 + m5 + m6 + m7) = r3$ (with r3 displayed on screen)

then $(m4 + m5 + m6 + m7 + m8) = r4$ (with r4 displayed on screen)

This cycle of measurement average calculations continues until a different measurement is selected.

Max Hold: Displays the measurement result that has the largest value. This mode is helpful for acquiring the maximum result, for example, when measuring off-the-air signals that are not stable. The Max Hold setting is available only for Signal Power measurements.

2-21 Advanced Settings Menu

Key Sequence: **Setup** > Advanced Settings

Advanced Settings	<p>Mode, GI: Press this submenu key to open the Select Mode, GI list box. Scroll through the list to select the Mode (number of subcarriers) and the size of the Guard Interval. For more information about Mode or Guard Interval, refer to “2K, 4K, 8K Modes and Guard Intervals” on page 2-3, “Automatic Detection of Parameters” on page 2-16, or “Digital Television Signal Analyzer Technology” on page 1-4.</p>
Mode, GI 8K, 1/8	<p>FFT Start: Press this submenu key to open the Select FFT Start list box. Scroll to select an FFT Start position to synchronize with the data that is used for measurement. A setting of 0/8 uses none of the guard interval (GI) and includes only the effective symbol (the data portion of the OFDM frame). A setting of 1/8 adjusts the FFT Start position to use 1/8 of the GI, and a setting of 8/8 adjusts the FFT Start position to use all of the GI.</p>
FFT Start 2/8	<p>Refer to Figure 1-3 on page 1-8 for details about the relationship between the FFT Start position and the guard intervals.</p>
Modulation 64QAM	<p>Modulation: Press this submenu key to open the Select Modulation list box. Scroll to select QPSK, 16QAM, or 64QAM modulation. The selection is displayed on the virtual submenu key face. Selecting QPSK automatically sets the Hierarchy, Alpha parameter to None.</p>
Hierarchy, Alpha None	<p>Hierarchy, Alpha: Press this submenu key to open the Select Hierarchy, Alpha list box. Scroll to select None, 1, 2, or 4. The selection is displayed on the submenu key face. This is used to shape the 16QAM and 64QAM constellations. A value of $\alpha=1$ describes an equally-spaced constellation.</p>
TPS Warning message(Details)	<p>TPS warning message(Details): Press this submenu key to open the TPS warning message (Details) message box. The warning and its description are displayed in the window. If measured TPS parameters are questionable, then look in this message box to check for any warnings.</p>
FFT Start Detection On <u>Off</u>	<p>FFT Start Detection On Off: Press this submenu key to specify the type of detect parameter operation performed when the user presses the Detect Parameter Once button or when in Auto Detect Parameter mode. When set to ON, the instrument detects the best possible FFT Start position, which is the FFT start position that yields the highest MER result in addition to the other MER parameters. When set to OFF, the detect parameter operation does not search for the best possible FFT Start position. This detect parameter setting is recommended to be On.</p>
Spectrum Reverse On <u>Off</u>	<p>Spectrum Reverse On Off: Press this submenu key to toggle the Spectrum Reverse function On or Off. The current state is underlined. Use Spectrum Reverse to measure the signal whose sub carrier location is inverted on the frequency axis, such as the IF signal of the transmitter.</p>
Back ←	<p>Back: Press this submenu key to return to the “Meas Setup Menu” on page 2-48.</p>

Figure 2-36. Advanced Settings Menu

2-22 Meas Selection Menu

Key Sequence: **Measurements**

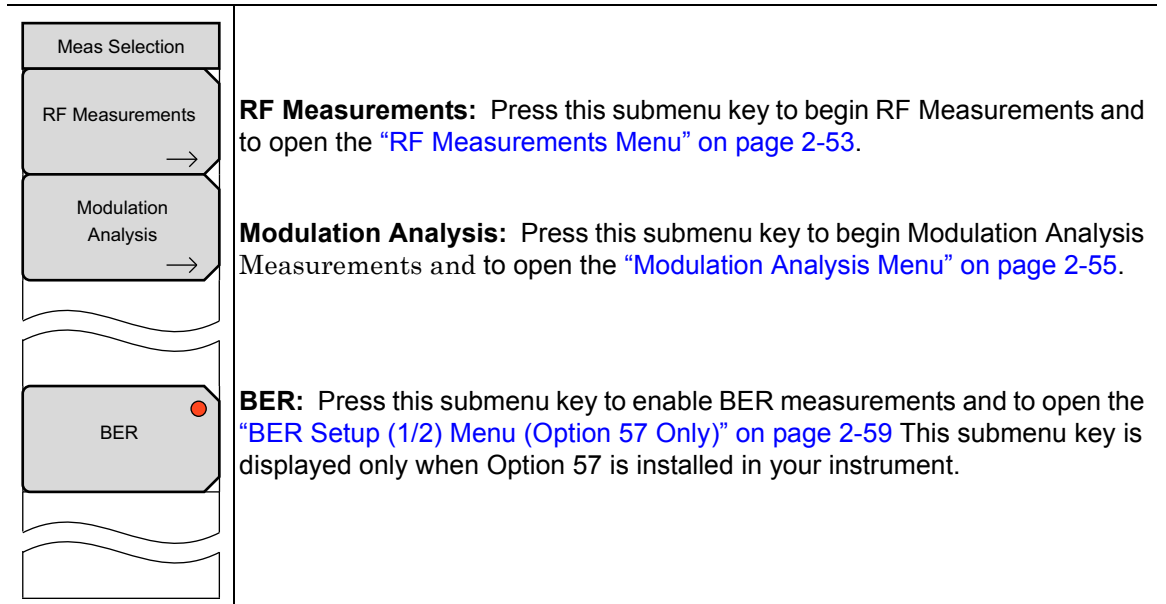


Figure 2-37. Measurement Selection Menu

2-23 Marker Menu

(For Impulse Response and Carrier MER Measurements Only)

Key Sequence: **Marker**

Marker	<p>Marker On Off: Press this submenu key to toggle markers On and Off. The current setting is underlined. Refer to “Marker Description” on page 2-52.</p> <p>Active Marker Zoom All: This feature is active when Marker is On. The Active Marker can be in the Zoom graph or in the All graph. Press this submenu key to toggle the setting between Zoom and All. The current state is underlined.</p> <p>Peak Search: This feature is active when Marker is On and the Active Marker is Zoom. Press this submenu key to place the green diamond marker on the highest signal amplitude that is displayed on the measurement screen.</p> <p>Delta Marker On Off: This feature is active only for Impulse Response measurements. Press this submenu key to toggle the Delta Marker On and Off. The current state is underlined.</p> <p>When Marker is set On, Active Marker is set to All, and Delta Marker is set On, the Delta Marker (small green square) is displayed within the marker of the Impulse Response (All) graph.</p> <p>When Marker is set On, Active Marker is set to Zoom, and Delta Marker is set On, the Delta Marker (small green square) is displayed within the marker of the Impulse Response (Zoom) graph.</p>
Marker <u>On</u> Off	
Active Marker <u>Zoom</u> All	
Peak Search	
Delta Marker <u>On</u> Off	

Figure 2-38. Marker Menu

Marker Description

Markers with Impulse Response

When Marker is set to On and Active Marker is set to All, a green outlined rectangle is displayed within the marker of the Impulse Response (All) graph. The signal that is outlined in the green rectangle is displayed in the Impulse Response (Zoom) graph. Use the rotary knob to move the green outlined rectangle in the +/- x-axis direction of the Impulse Response (All) graph.

When Marker is set to On and Active Marker is set to Zoom, a small green diamond is displayed in the Impulse Response (Zoom) graph.

Markers with Carrier MER

When Marker is set to On and Active Marker is set to All, a green outlined rectangle is displayed in the Carrier MER (All) graph. The signal that is outlined by the green box is displayed in the Carrier MER (Zoom) graph.

When Marker is set to On and Active Marker is set to Zoom, a green a small green diamond is displayed in the Carrier MER (Zoom) graph.

2-24 RF Measurements Menu

Key Sequence: **Measurements** > RF Measurements

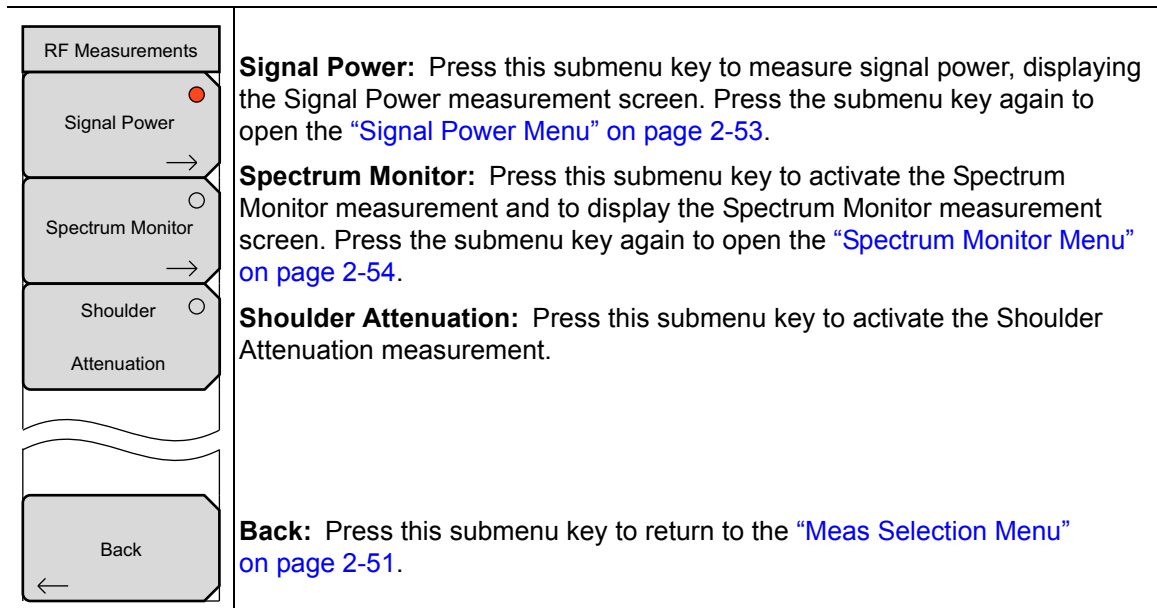


Figure 2-39. RF Measurements Menu

2-25 Signal Power Menu

Key Sequence: **Measurements** > RF Measurements > Signal Power

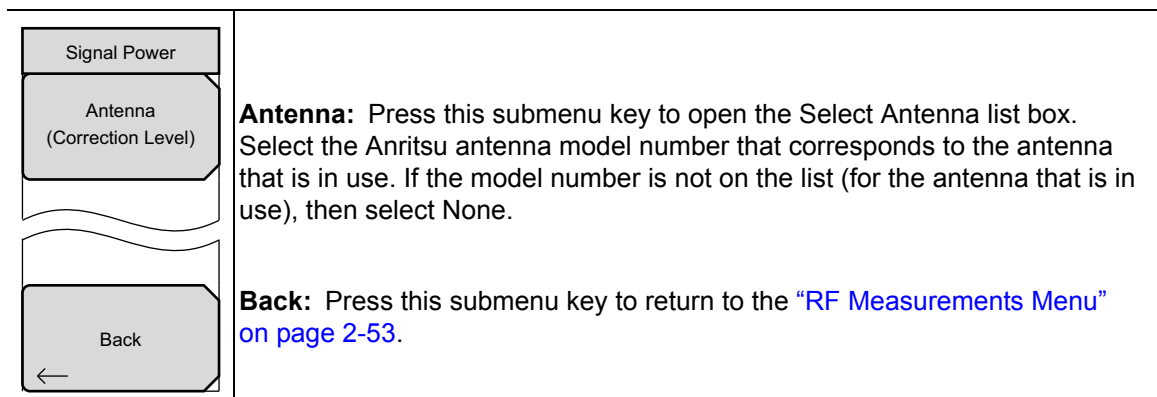


Figure 2-40. Signal Power Menu

2-26 Spectrum Monitor Menu

Key Sequence: **Measurements** > RF Measurements > Spectrum Monitor

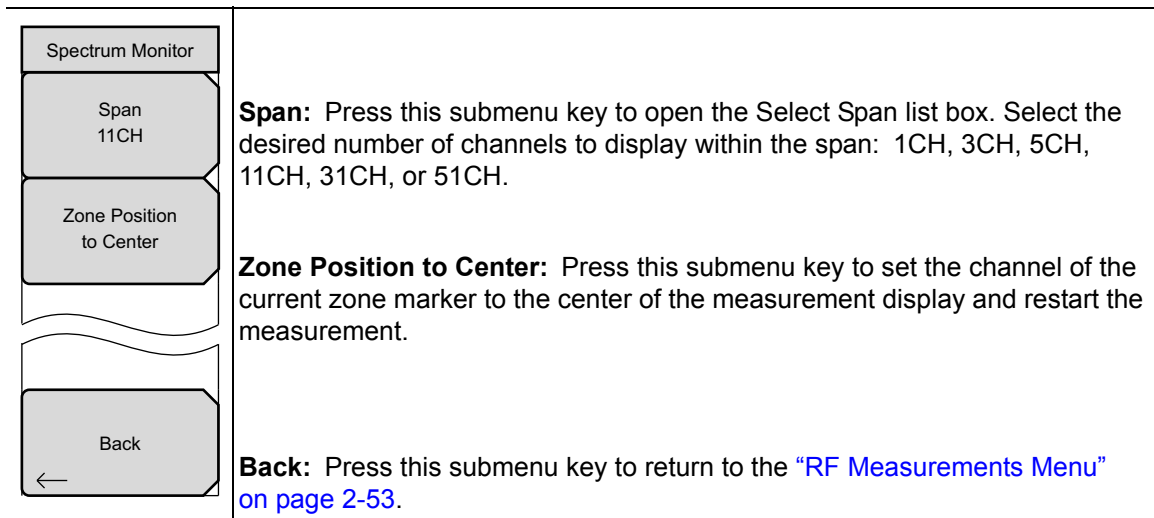


Figure 2-41. Spectrum Monitor Menu

2-27 Modulation Analysis Menu

Key Sequence: **Measurements** > Modulation Analysis

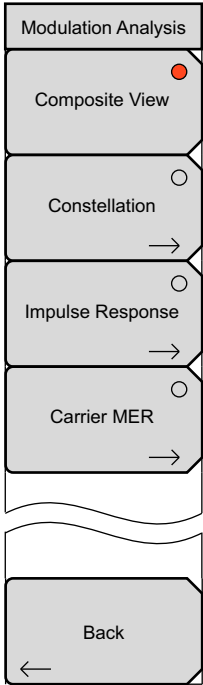
	<p>Composite View: Press this submenu key to display the Constellation (Data & TPS), Impulse Response (All), Carrier MER, and Frequency Response graphs on the instrument display screen.</p> <p>Constellation: Press this submenu key to display the Constellation view. Press the submenu key again to open the “Constellation Menu” on page 2-55.</p> <p>Impulse Response: Press this submenu key to display the Impulse Response (All) and Impulse Response (Zoom) graphs. Press the submenu key again to open the “Impulse Response Menu” on page 2-56.</p> <p>Carrier MER: Press this submenu key to display the Carrier MER (All) and Carrier MER (Zoom) graphs. Press the submenu key again to open the Carrier MER menu “Carrier MER Menu” on page 2-58.</p> <p>Back: Press this submenu key to return to the “Meas Selection Menu” on page 2-51.</p>
---	---

Figure 2-42. Modulation Analysis Menu

2-28 Constellation Menu

Key Sequence: **Measurements** > Modulation Analysis > Constellation

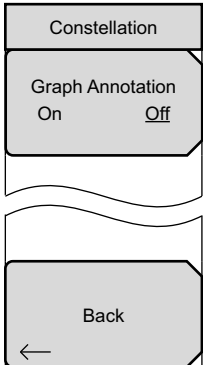
	<p>Graph Annotation On Off: Press this submenu key to toggle the grid line display On and Off (8x8 for 64QAM, 4x4 for 16QAM, and 2x2 for QPSK). The current setting is underlined.</p> <p>Back: Press this submenu key to return to the “Modulation Analysis Menu” on page 2-55.</p>
---	--

Figure 2-43. Constellation Menu

2-29 Impulse Response Menu

Key Sequence: **Measurements** > Modulation Analysis > Impulse Response

Impulse Response	0μs Position: Press this submenu key to open the Select 0 μ s Position list box to allow selecting a zero microsecond signal display position on the Impulse Response graphs. Changing this setting can affect the FFT Start position. For more information about this relationship, refer to section “FFT Start” on page 2-4 .
0 μ s Position Left	
Path_Posn_Keep On Off	Path_Posn_Keep On Off: Press this submenu key to toggle this feature On or Off. When Off, the main signal is placed at the center of the graph, and the delayed signal is displayed to the right of the main signal. If the amplitude of the delayed signal becomes larger than the amplitude of the main signal, then the delayed signal will be repositioned to the center of the graph. When Path_Posn_Keep is On, the main and delayed signals are locked in place, whether or not the amplitude of the delayed signal becomes greater than the amplitude of the main signal.
Vertical Range →	
Back ←	Vertical Range: Press this submenu key to open the “Vertical Range Menu (Impulse Response)” on page 2-57 . Back: Press this submenu key to return to the “Modulation Analysis Menu” on page 2-55 .

Figure 2-44. Impulse Response Menu

2-30 Vertical Range Menu (Impulse Response)

Key Sequence: **Measurements** > Modulation Analysis > Impulse Response > Vertical Range

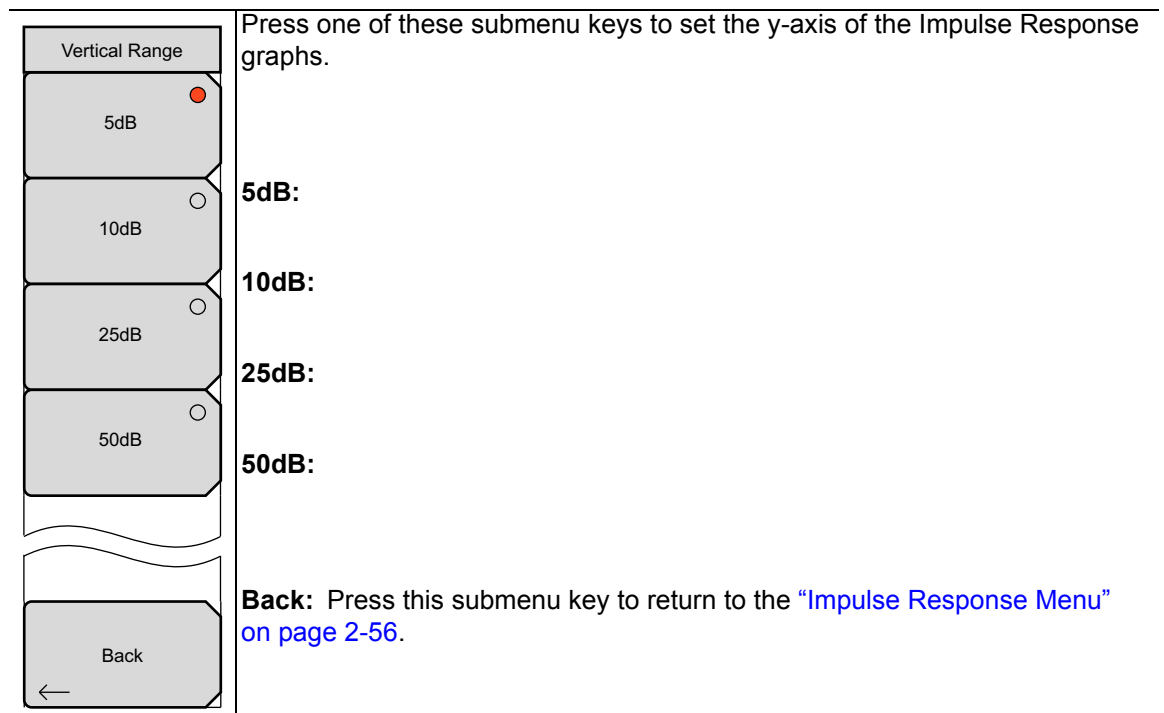


Figure 2-45. Vertical Range Menu (Impulse Response)

2-31 Carrier MER Menu

Key Sequence: **Measurements** > Modulation Analysis > Carrier MER

Carrier MER	
Vertical Range →	Vertical Range: Press this submenu key to open the “Vertical Range Menu (Carrier MER)” on page 2-58.
Measurement Type Speed Accuracy	Measurement Type Speed Accuracy: Press this submenu key to toggle this feature to Speed for a faster measurement, or to Accuracy for a more precise measurement.
Back ←	Back: Press this submenu key to return to the “Modulation Analysis Menu” on page 2-55.

Figure 2-46. Carrier MER Menu

2-32 Vertical Range Menu (Carrier MER)

Key Sequence: **Measurements** > Modulation Analysis > Carrier MER > Vertical Range

Vertical Range	Press one of these submenu keys to set the y-axis of the Carrier MER graphs.
20dB	20dB:
30dB	30dB:
40dB	40dB:
50dB	50dB:
Back ←	Back: Press this submenu key to return to the “Carrier MER Menu” on page 2-58.

Figure 2-47. Vertical Range Menu (Carrier MER)

2-33 BER Setup (1/2) Menu (Option 57 Only)

Key Sequence: **Measurements** > BER

Meas Setup(1/2)	Meas Mode: Press this submenu key to open the Select Meas Mode list box. Scroll through the list to select the desired Measurement Mode: Single, Continuous, Average, Moving Average, and Max Hold. Refer to “Meas Mode Settings” on page 2-49.
Meas Mode Single	
Bit Count Setting 3E+07	Bit Count Setting: Press this submenu key to open the Bit Count Setting Editor and the “BER Bit Count Setting Menu (Option 57 Only)” on page 2-60. Use the Mantissa or Exponent submenu key to select between these parameters for editing. Enter the desired mantissa and exponent. The mantissa value ranges from 1 to 9, and the exponent value ranges from 6 to 12. Resolution for each is 1.
Service Out of Service	Service: Press this submenu key to open the Select Service list box. Scroll to select In Service or Out of Service. Refer to “Service” on page 2-59.
Stream HP	Stream: Press this submenu key to open the Select Stream list box. Scroll to select between high priority (HP) or low priority (LP) signal stream.
BER Meas Point Before RS	BER Meas Point: This submenu key is displayed only when the Service submenu key is set to Out of Service. Press this submenu key to open the Select BER Meas Point dialog box. Select the desired view of the measurement taken. Refer to “BER Measurement Point” on page 2-60. This submenu key is displayed only when Out of Service is selected. Refer to “Service” on page 2-59.
Result Disp Current Last	Result Disp Current Last: Press this submenu key to toggle the displayed result, choosing either to view the Current measurement or to view the Last measurement taken. The Current measurement display is periodically updated.
More →	More: Press this submenu key to open the “BER Setup (2/2) Menu (Option 57 Only)” on page 2-61.

Figure 2-48. BER Setup (1/2) Menu

Service

In Service: Select this mode when the input signal is a broadcast wave. The BER measurement point is fixed to Before RS and Before Viterbi. This mode also performs a Packet Error Rate (PER) measurement.

Out of Service: Select this mode when the input signal is PRBS23. The measurement point can be selected from Before RS, After RS, and Before Viterbi. PER (Packet Error Rate) is measured only when After RS is selected.

BER Measurement Point

This submenu key is displayed only when the **Service** submenu key is set to **Out of Service**.

Before Viterbi: Sets the measurement point before the Viterbi decoder. No error count is displayed when **Before Viterbi** is selected as the BER measurement point.

Before RS: Sets the measurement point before the Reed-Solomon decoder.

After RS: Sets the measurement point after the Reed-Solomon decoder.

2-34 BER Bit Count Setting Menu (Option 57 Only)

Key Sequence: **Measurements** > **BER** > **Bit Count Setting**

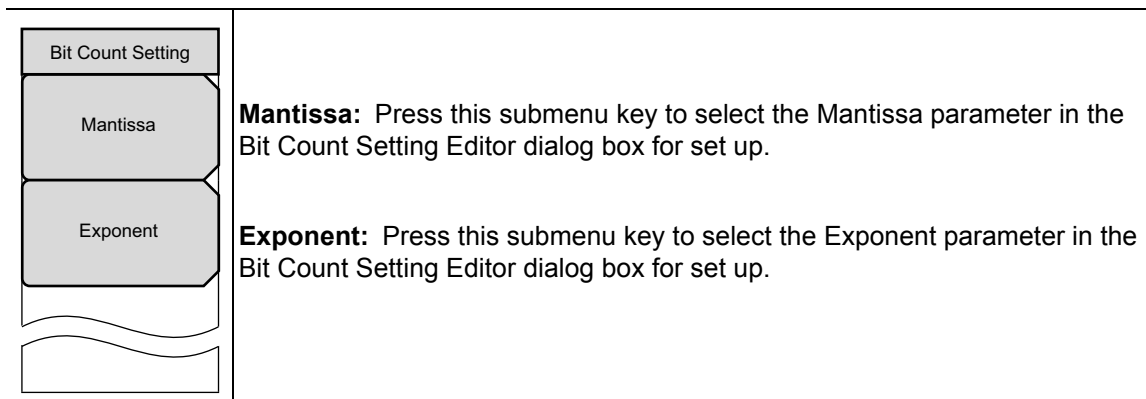


Figure 2-49. BER Bit Count Setting Menu

2-35 BER Setup (2/2) Menu (Option 57 Only)

Key Sequence: **Measurements** > BER > More

Meas Setup(2/2)	TS Packet: Press this submenu key to open the Select TS Packet list box in order to select one of the following packet settings:
TS Packet 1+[187]+16	1+[187]+16: Sets the TS packet to 187 bytes.
Spectrum Reverse On <u>Off</u>	4+[184]+16: Sets the TS packet to 184 bytes.
	Spectrum Reverse On Off: Press this submenu key to toggle the Spectrum Reverse function On or Off. Use Spectrum Reverse to measure the signal whose sub carrier location is inverted on the frequency axis, such as the IF signal of the transmitter.
TPS Warning message(Details)	TPS warning message (Details): Press this submenu key to open the TPS warning message (Details) message box. The warning and its description are displayed in the window. If measured TPS parameters are questionable, then look in this message box to check for any warnings.
Back ←	Back: Press this submenu key to return to the “BER Setup (1/2) Menu (Option 57 Only)” on page 2-59.

Figure 2-50. BER Setup (2/2) Menu

Chapter 3 — DVB-T/H SFN Signal Analyzer

(Option 78, Option MS8911B-0052)

3-1 Introduction

This chapter describes DVB-T/H single frequency network (SFN) setup and measurement for signal power and signal analysis with Option 78 (or Option MS8911B-0052), which requires that your instrument also has Option 64 installed. Note that Option 9 (IQ Demodulation Hardware) may also be required in your instrument in order to use Option 78. You can measure channel power along with the field strength and power of each incoming signal even with several incoming multipath signals. The time for impulse response measurements is longer in order to allow for the measurement of signals coming from distant sites in the network.

Field strength measurements in SFN environments include Level, Delay, and DU Ratio of each incoming signal along with the time delay between signals.

Screen images of measurements, as shown in this document, are examples. The images on your instrument may differ in appearance.

The main menu keys in this instrument mode are:

Frequency Amplitude Setup Measurements Marker

3-2 Instrument Connections

Attach the antenna to the connector labeled Spectrum Analyzer RF In on top of the instrument. [Figure 1-1 on page 1-3](#) is an example of an Anritsu handheld instrument. Refer to your User Guide for a description of the connectors on your instrument.

3-3 Digital Television Signal Analyzer Technology

Carrier modes, OFDM carriers, Guard Intervals, the FFT Start position, and other DVB-T/H functions are described in [Chapter 1, Section 1-6 “Digital Television Signal Analyzer Technology” on page 1-4](#) and [Section 2-3 “Digital Television Signal Analyzer Technology” on page 2-1](#).

3-4 Measurement Functions

The two basic measurements for DVB-T/H SFN are Impulse Response and Inband Spectrum. Figure 3-1 and Figure 3-2 are typical examples of Impulse Response and Inband Spectrum measurements, but these images may differ from any image that is displayed on your instrument.

Impulse Response Measurement

The Impulse Response function is useful for adjusting the timing of SFN repeaters. This function measures the difference in time of multipath signals. The graph shows the existence of multipath signals and their relative power and time separation, which can be useful for network planning.

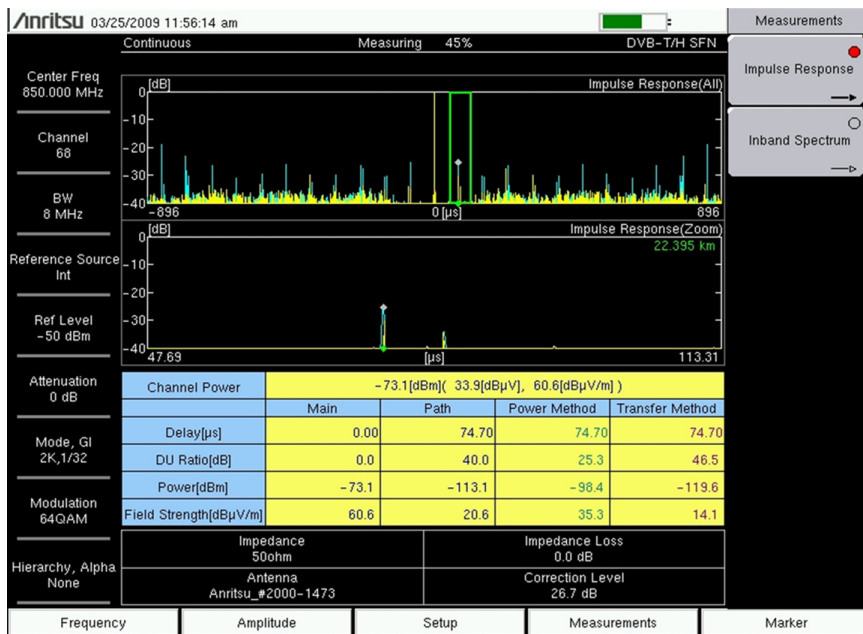


Figure 3-1. Impulse Response Measurement

Inband Spectrum Measurement

The Inband Spectrum measurement is a Frequency Response function. By measuring the channel frequency response, both the multipath effect and frequency selective fading can be observed.

This function is useful for transmitter installation or maintenance because it offers a wide dynamic range (50 dB) on the vertical scale for high-performance transmitters. It also offers precise checks of each carrier by providing a zoom view for all carriers on the horizontal scale.

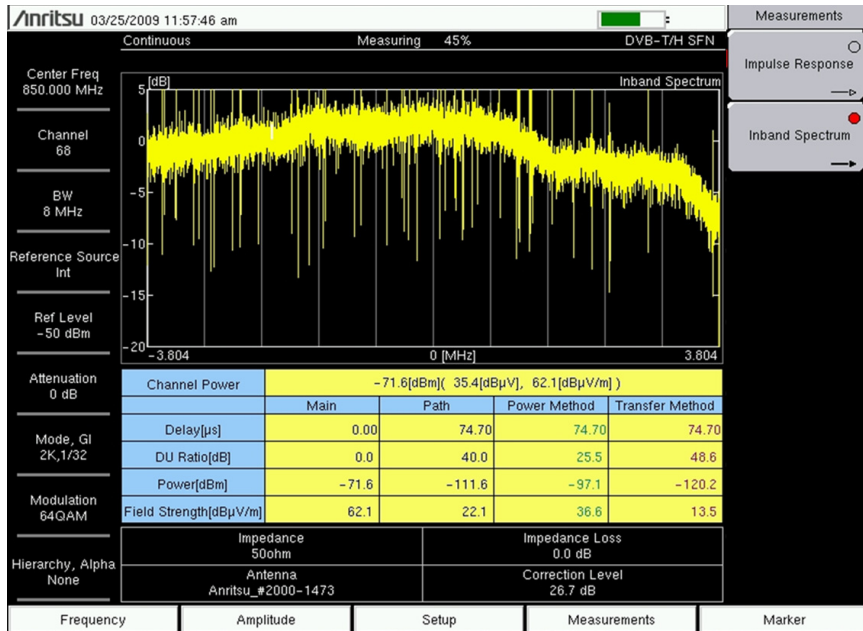


Figure 3-2. Inband Spectrum Measurement

3-5 General Measurement Setups

Please refer to your instrument User Guide for directions about selecting the DVB-T/H SFN mode.

Antenna Setup

The antenna attaches to the instrument with a coaxial cable. The antenna and coaxial cable are not supplied with the instrument and must be procured separately.

The antenna factors are different for each antenna. Refer to the documentation for your antenna. Also, remember to add the cable loss to the measurement correction table. You can use Master Software Tools (MST) to update your antenna and coaxial cable lists. For directions about updating these lists, refer to the Master Software Tools documentation (available from www.anritsu.com).

1. Attach the antenna to the Spectrum Analyzer connector on top of your instrument (refer to the User Guide for your instrument).

Select the antenna as follows:

2. Press the **Setup** main menu key to open the “Meas Setup (1/2) Menu 5”.
3. Press the Advanced Settings submenu key to open the “Meas Setup (2/2) Menu”.
4. Press the Antenna (Correction Level) submenu key.
5. In the Select Antenna list box, scroll to the desired Anritsu antenna model number by using the **Up/Down** arrow keys or the rotary knob, and press the rotary knob or the **Enter** key to select it. Note that the **Left/Right** arrow keys jump directly to the top and bottom of the antenna list.

Setting up the Measurement Frequency

The measurement frequency can be set by entering the center frequency or by selecting the applicable signal standard and channel, which allows the instrument to automatically set the frequency.

To Set the Measurement Frequency by Entering the Center Frequency:

1. Press the **Frequency** main menu key.
2. Press the Center Freq submenu key.
3. Enter the required frequency by using the keypad, the arrow keys, or the rotary knob. When entering a frequency by using the keypad, the submenu key labels change to GHz, MHz, kHz, and Hz. Press the appropriate unit key. Pressing the **Enter** key has the same effect as pressing the MHz submenu key. The current setting is shown at the top of the instrument settings summary column on the left side of the screen.

To Set the Measurement Frequency by Selecting a Signal Standard:

1. Press the **Frequency** main menu key.
2. Press the Signal Standard submenu key to open the Signal Standards dialog box. Select the desired signal standard. When a signal standard is selected, the center frequency for the channel of the selected standard is automatically tuned.
3. Press the Channel submenu key to open the Channel Editor dialog box and set the channel within the specified range.

4. If necessary, press the **Frequency Offset** submenu key to offset the channel frequency (using the values from the **Select Frequency Offset** dialog box).

Bandwidth Setup

1. Press the **Bandwidth** submenu key to display a set of available bandwidths: 5 MHz, 6 MHz, 7 MHz, or 8 MHz.
2. Use the **Up/Down** arrow keys or the rotary knob to highlight the applicable bandwidth in the list, and then press the **Enter** key to set the bandwidth. The selected bandwidth is displayed in the instrument settings summary column.

Amplitude Setup

1. Press the **Amplitude** main menu key to open the **“Amplitude Menu”**.
2. Press the **Auto Reference Level** submenu key to allow the instrument to set an optimum reference level, or press the **Reference Level** submenu key to manually set the reference level.

When the **Reference Level Editor** dialog box opens, enter the desired reference value.

3. If the input signal is weak, then press the **Pre Amp** sub menu key to toggle this function On.
4. Press the **Impedance** sub menu key to toggle through to the desired impedance parameter: 50 ohm, 75 ohm, or Other. If you select Other, then the **Impedance Loss** submenu key is displayed in the menu. Impedance Loss is set manually.

Press the **Impedance Loss** sub menu key to open the **Impedance Loss Editor** dialog box and select a dB loss level within the displayed range.

Measurement Setup

1. Press the **Setup** main menu key to open the **“Meas Setup (1/2) Menu 5”**.
2. Press the **Meas Mode** submenu key to open the **Select Meas Mode** list box and choose between **Single** or **Continuous** measurement sweeps.
3. Press the **Trigger Sweep** submenu key to begin a sweep (a single measurement sweep if **Meas Mode** is set to **Single**, or multiple measurement sweeps if **Meas Mode** is set to **Continuous**).

If **Meas Mode** is set to **Continuous**, then pressing **Trigger Sweep** interrupts any measurement sweep that is in process and restarts a new measurement sweep.

4. Press the **Detect Parameter Once** submenu key to detect for **Mode**, **GI**, **Modulation**, and **Hierarchy** parameters.
5. Press the **Advanced Settings** submenu key to continue measurement setup by using the **“Meas Setup (2/2) Menu”**.
6. Press the **Mode, GI** submenu key to select the desired width of the guard interval.
7. Press the **Modulation** submenu key and choose the desired modulation type: **QPSK**, **16QAM**, and **64QAM**.
8. Press the **Hierarchy, Alpha** submenu key and choose: **None**, **1**, **2**, or **4**.

9. Press the **Spectrum Reverse** submenu key to toggle between **On** and **Off**. The current setting is underlined. Use **Spectrum Reverse** to measure a signal whose sub carrier location is inverted on the frequency axis, such as the IF signal of the transmitter.
10. Press the **Back** submenu key to return to the Setup (1/2) menu.

3-6 Impulse Response Measurements

Refer to [Figure 3-1 on page 3-2](#) for a typical screen image of an Impulse Response measurement.

1. Press the **Measurements** main menu key.
2. Press the Impulse Response submenu key to select and display the Impulse Response measurement screen.
3. Press the Impulse Response submenu key again to open the **“Impulse Response Menu”** in order to set up the y-axis vertical range and the waveform display.

Vertical Range

1. Press the Vertical Range submenu key to open the Vertical Range menu.
2. Press one of the four range-value submenu keys to set the vertical axis (y-axis) of the Impulse Response graphs to: 5 dB, 10 dB, 20 dB, or 40 dB.
3. Press Back to return to the Impulse Response menu.

Display Waveform

1. Press the Display Waveform submenu key to open the **“Display Waveform Menu”**.
2. Set up the following parameters by pressing each submenu key (if necessary) to toggle the setting On or Off: Last Result, Power Method, and Transfer Method. The current setting of each parameter is underlined.
3. Press Back to return to the Impulse Response menu.

3-7 Inband Spectrum Measurements

Refer to [Figure 3-2 on page 3-3](#) for a typical screen image of an Inband Spectrum measurement.

1. Press the **Measurements** main menu key.
2. Press the Inband Spectrum submenu key to select and display the Inband Spectrum measurement screen.
3. Press the Inband Spectrum submenu key again to open the **“Inband Spectrum Menu”** and to set up the y-axis vertical range.

Vertical Range

1. Press the Vertical Range submenu key to open the Vertical Range menu.
2. Press one of the four range-value submenu keys to set the vertical axis (y-axis) of the Inband Spectrum graphs to: 5 dB, 10 dB, 25 dB, or 50 dB.
3. Press Back to return to the **“Inband Spectrum Menu”**.

3-8 DVB-T/H SFN Menus

In some Anritsu manuals, **main menu keys** may also be called **hard keys**, and submenu keys may also be called **soft keys**.

Main Menu Group

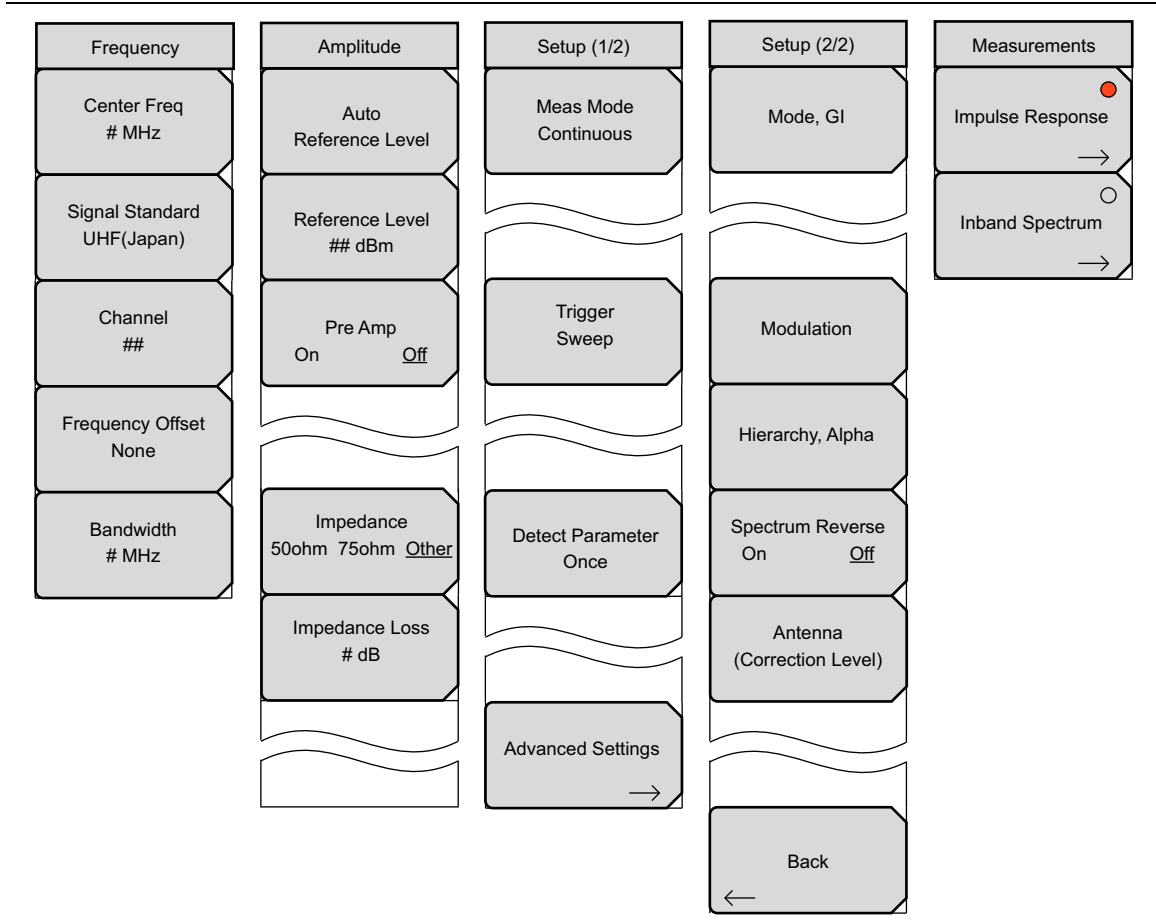


Figure 3-3. Main Menu Group

Measurements Menu Group

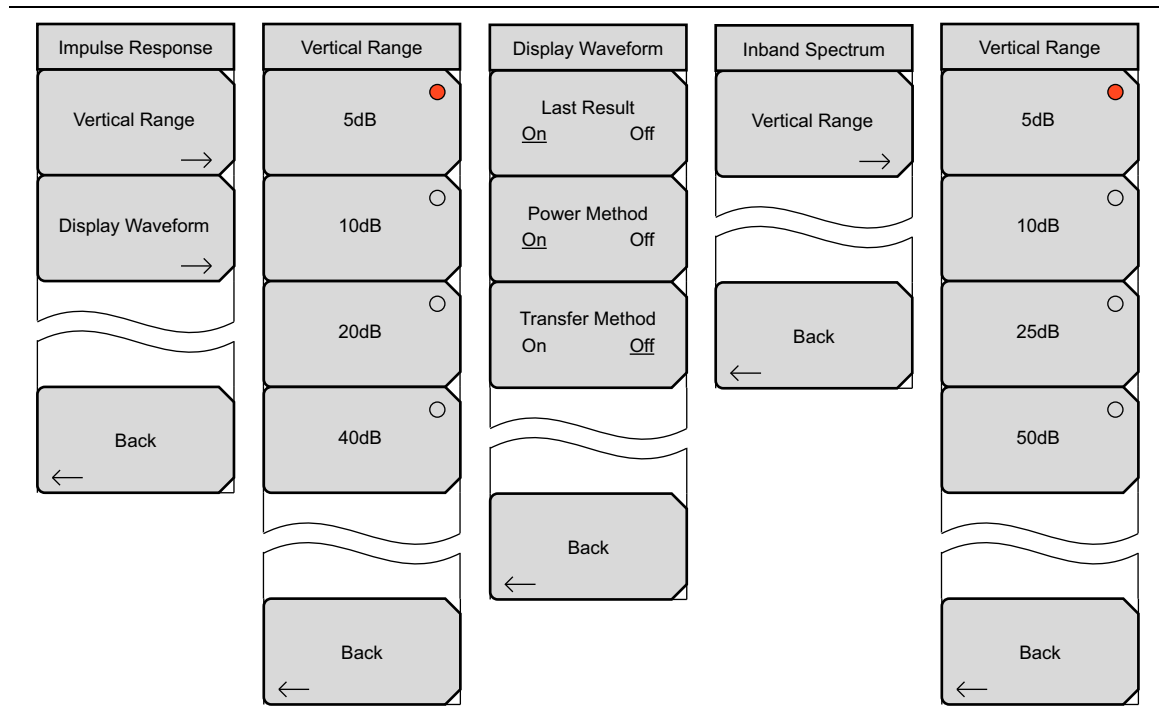


Figure 3-4. Measurements Menu Group

Marker Menu Group

The Marker menu for Impulse Response measurements utilizes 7 submenu keys. The Marker menu for Inband Spectrum measurements utilizes only 2 submenu keys.

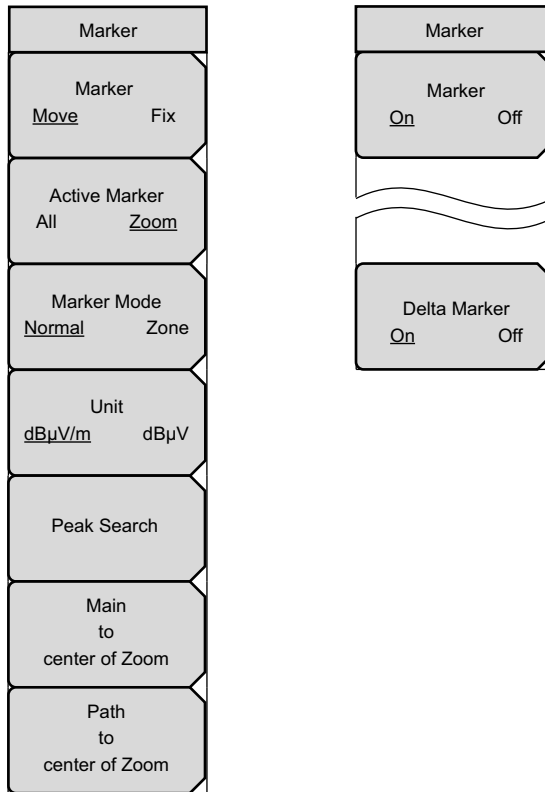


Figure 3-5. Marker Menu Group

3-9 Freq (Frequency) Menu

Key Sequence: **Frequency**

Frequency	<p>Center Freq: Press this submenu key to open the Frequency Editor dialog box to allow entering a center frequency. Range is from 30 MHz to 2800 MHz in 1 Hz steps.</p>
Center Freq # MHz	<p>Signal Standard: Press this submenu key to open the Signal Standards list box to allow channel map selections for Digital Terrestrial TV UHF(Japan), Digital Terrestrial TV UHF(Europe), or Digital Terrestrial TV UHF(Australia). Bandwidths are automatically set for each region:</p> <p style="padding-left: 40px;">Japan: 6 MHz</p> <p style="padding-left: 40px;">Europe: 8 MHz</p> <p style="padding-left: 40px;">Australia: 7 MHz</p>
Signal Standard UHF(Japan)	
Channel ##	<p>Channel: Press this submenu key to open the Channel Editor dialog box in order to select a channel within a specified UHF region (that is subsequently displayed on the Signal Standard submenu key). Use the Up/Down arrow keys, the keypad, or the rotary knob to set a channel number for the selected signal standard. The center of the channel is automatically tuned to the center frequency of the selected channel. The channel range for each country is:</p> <p style="padding-left: 40px;">Japan: channels 13 to 62</p> <p style="padding-left: 40px;">Europe: channels 21 to 69</p> <p style="padding-left: 40px;">Australia: channels 28 to 69.</p>
Frequency Offset None	
Bandwidth # MHz	<p>Frequency Offset: Press this submenu key to open the Select Frequency Offset list box. Select None or one of the six offset frequencies: -499.999 kHz, -333.333 kHz, -166.666 kHz, None, 166.666 kHz, 333.333 kHz, 499.999 kHz.</p> <p>Bandwidth: Press this submenu key to open the Select Band Width list box and manually select a bandwidth: 5 MHz, 6 MHz, 7 MHz, or 8 MHz.</p>

Figure 3-6. Frequency Menu

3-10 Amplitude Menu

Key Sequence: **Amplitude**

Amplitude	<p>Auto Reference Level: Press this submenu key to automatically set the reference level to an optimum value. This reference level indicates the signal level input to the instrument. The reference level range for signal input to the instrument is determined by the reference level setting. Immediately after a signal is applied to the instrument, the input attenuator is automatically set according to the reference level. The relationship between the reference level and the input attenuator is fixed. The power levels and offset levels for this relationship are listed in Table 3-1.</p>
Auto Reference Level	<p>Raising the reference level increases attenuation of the input attenuator, enabling the user to handle a high input level. Note that the noise floor rises in proportion to the attenuation of the input attenuator.</p>
Reference Level ## dBm	<p>When applying a signal to the instrument, input a signal level that does not exceed the reference level value. If the signal level exceeds the reference level, raise the reference level. For example, if the signal level is 0.5 dBm with preamplifier off, set the reference level to 5 dBm, not to 0 dBm.</p>
Pre Amp On Off	<p>If an interfering wave other than the intended signal exists, and if the power is 15 dB or more higher than the measurement signal level, then set the reference level to take the large signal into account.</p>
Impedance 50ohm 75ohm Other	<p>Reference Level: Opens the Reference Level Editor dialog box in order to select a signal reference value within the specified range that is displayed in the window. If the Pre Amp submenu key indicates On, then the reference level range is from –10 dBm to –50 dBm in 10 dB increments. If the Pre Amp submenu key indicates Off, then the reference level range is from –25 dBm to 20 dBm in 5 dB increments. Refer to Table 3-1 on page 3-13 for the reference level relationship to input attenuation and preamplifier setting.</p>
Impedance Loss # dB	<p>Pre Amp On Off: Press this submenu key to turn on or off the low-noise front-end preamplifier. To assure accurate measurement results, the largest signal into the instrument input when the preamplifier is turned on should be less than –40 dBm.</p>
	<p>Impedance 50 Ohm 75 Ohm Other: Press this submenu key to toggle the selection to 50 ohm, 75 ohm, or Other impedance value. Selecting 75 ohm selects the 7.5 dB loss of the Anritsu 12N50-75B adapter. For other adapters, select “Other” and enter the appropriate loss.</p>
	<p>Impedance Loss: This submenu key is displayed only when the Impedance submenu key is set to Other. Press this submenu key to open the Impedance Loss Editor edit box and set a dB value.</p> <p>Set the impedance loss in the range of 0.0 dB to 100.0 dB (in 0.1 dB steps) when the impedance is set to Other (which is also 75 ohms). Set 1.9 dB when using the MA1621A impedance transformer as the impedance converter.</p>

Figure 3-7. Amplitude Menu

Reference Level Relationship to Input Attenuation and Preamplicifier Setting

Table 3-1. Fixed Relationship of Input Attenuator to Auto Reference Level

Preamplicifier	Reference Level	Input Attenuator
Off	20 dBm	45 dB
Off	15 dBm	40 dB
Off	10 dBm	35 dB
Off	5 dBm	30 dB
Off	0 dBm	25 dB
Off	-5 dBm	20 dB
Off	-10 dBm	15 dB
Off	-15 dBm	10 dB
Off	-20 dBm	5 dB
Off	-25 dBm	0 dB
On	-10 dBm	40 dB
On	-20 dBm	30 dB
On	-30 dBm	20 dB
On	-40 dBm	10 dB
On	-50 dBm	0 dB

3-11 Meas Setup (1/2) Menu 5

Key Sequence: **Setup**

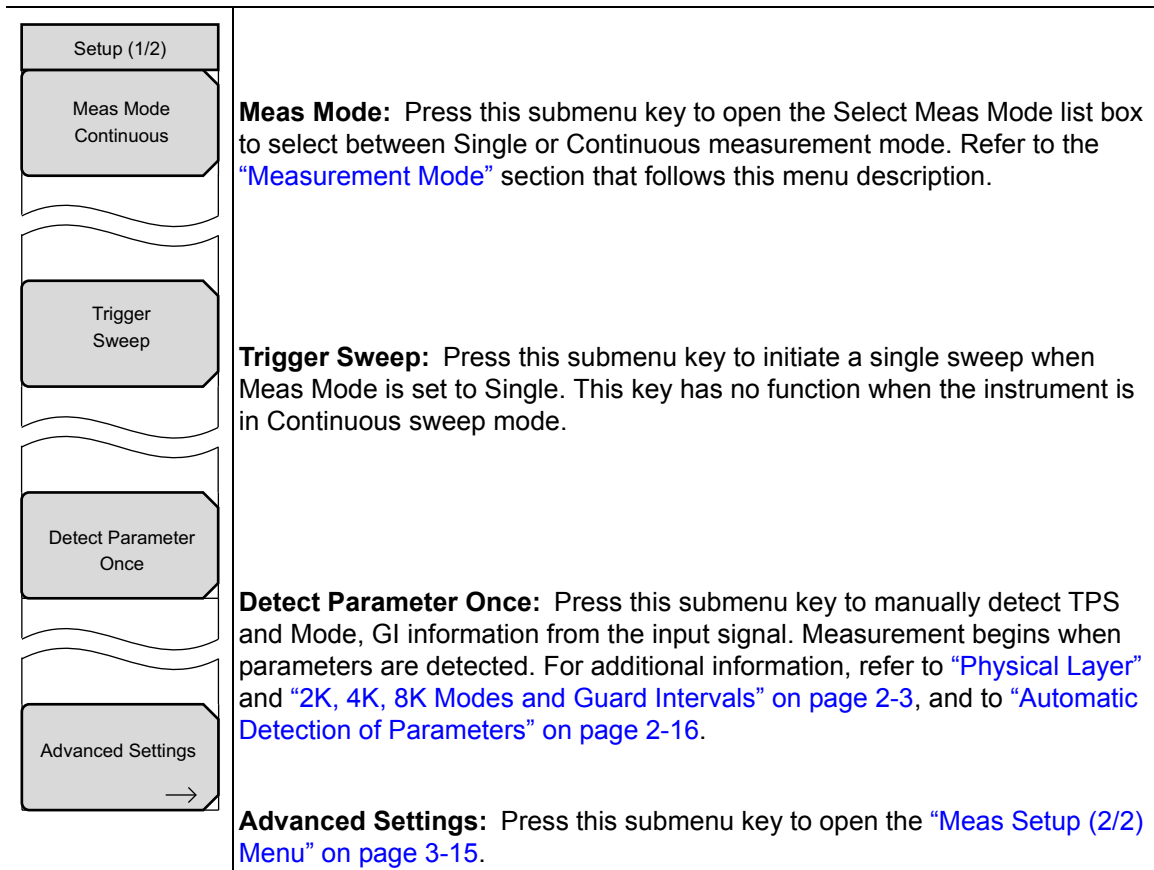


Figure 3-8. Meas Setup (1/2) Menu

Measurement Mode

Single measurement mode sets up the test for one measurement. The instrument acquires the measurement and displays the results. This mode is useful for capturing screen images. Press the Trigger Sweep submenu key when you are ready to take a measurement.

Continuous measurement mode sets up the instrument to take measurements continuously and display the results. This mode is helpful for real-time signal analysis.

3-12 Meas Setup (2/2) Menu

Key Sequence: **Setup** > Advanced Settings

Setup (2/2)	
Mode, GI	<p>Mode, GI: Press this submenu key to open the Select Mode, GI list box. Scroll through the list to select the Mode (number of subcarriers) and the size of the Guard Interval (GI). For more information about Mode or Guard Interval, refer to “2K, 4K, 8K Modes and Guard Intervals” on page 2-3, and “Digital Television Signal Analyzer Technology” on page 1-4.</p>
Modulation	<p>Modulation: Press this submenu key to open the Select Modulation list box. Scroll to select QPSK, 16QAM, or 64QAM modulation. The Hierarchy, Alpha parameter is set to None automatically by selecting QPSK.</p>
Hierarchy, Alpha	<p>Hierarchy, Alpha: Press this submenu key to open the Select Hierarchy, Alpha list box. Scroll to select None, 1, 2, or 4. The selection is displayed on the submenu key face. This selection is used to shape the 16QAM and 64QAM constellations. A value of $\alpha=1$ describes an equally-spaced constellation.</p>
Spectrum Reverse On Off	<p>Spectrum Reverse On Off: Press this submenu key to toggle the Spectrum Reverse feature On and Off. Use Spectrum Reverse to measure the signal whose sub carrier location is inverted on the frequency axis, such as the IF signal of the transmitter.</p>
Antenna (Correction Level)	<p>Antenna (Correction Level): Press this submenu key to open the Select Antenna list box. Select the Anritsu antenna model number that corresponds to the antenna in use. If the model number of the antenna that is in use is not on the list, then select None.</p>
Back ←	<p>Back: Press this submenu key to return to the “Meas Setup (1/2) Menu 5” on page 3-14.</p>

Figure 3-9. Meas Setup (2/2) Menu

3-13 Measurements Menu

Key Sequence: **Measurements**

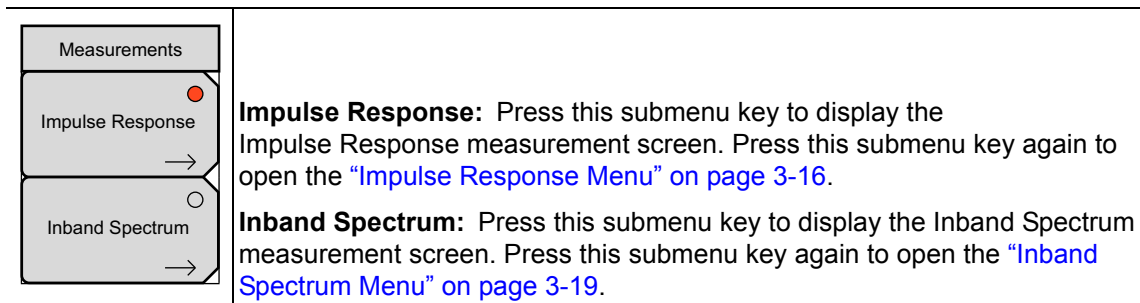


Figure 3-10. Measurements Menu

3-14 Impulse Response Menu

Key Sequence: **Measurements** > Impulse Response

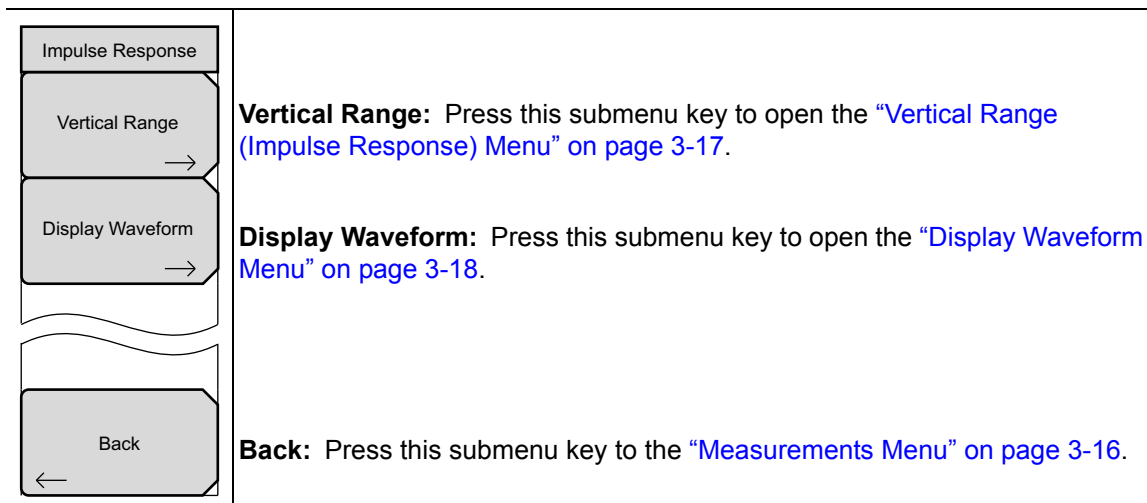


Figure 3-11. Impulse Response Menu

3-15 Vertical Range (Impulse Response) Menu

Press one of the four submenu keys in this menu to set the y-axis of the Impulse Response graph.

Key Sequence: **Measurements** > Impulse Response






Vertical Range	Press one of these submenu keys to set the y-axis of the Impulse Response graphs.
5dB 	5dB:
10dB 	10dB:
20dB 	20dB:
40dB 	40dB:
Back 	Back: Press this submenu key to the "Impulse Response Menu" on page 3-16.

Figure 3-12. Vertical Range (Impulse Response) Menu

3-16 Display Waveform Menu

These submenu keys allow you to choose the desired waveforms to view in the Impulse Response graphs.

Key Sequence: **Measurements** > Impulse Response > Display Waveform



Display Waveform	
Last Result <input type="radio"/> On <input type="radio"/> Off	Last Result On Off: Press this submenu key to turn On or Off a display of the last measured waveform (displayed in yellow).
Power Method <input type="radio"/> On <input type="radio"/> Off	Power Method On Off: Press this submenu key to turn On or Off a display of the delay path profile waveform (displayed in light blue) that is created by the power spectrum method.
Transfer Method <input type="radio"/> On <input type="radio"/> Off	Transfer Method On Off: Press this submenu key to turn On or Off a display of the delay path profile waveform (displayed in magenta) that is created by the transfer function method.
	
Back 	Back: Press this submenu key to the “Impulse Response Menu” on page 3-16.

Figure 3-13. Display Waveform Menu

3-17 Inband Spectrum Menu

Key Sequence: **Measurements** > Inband Spectrum

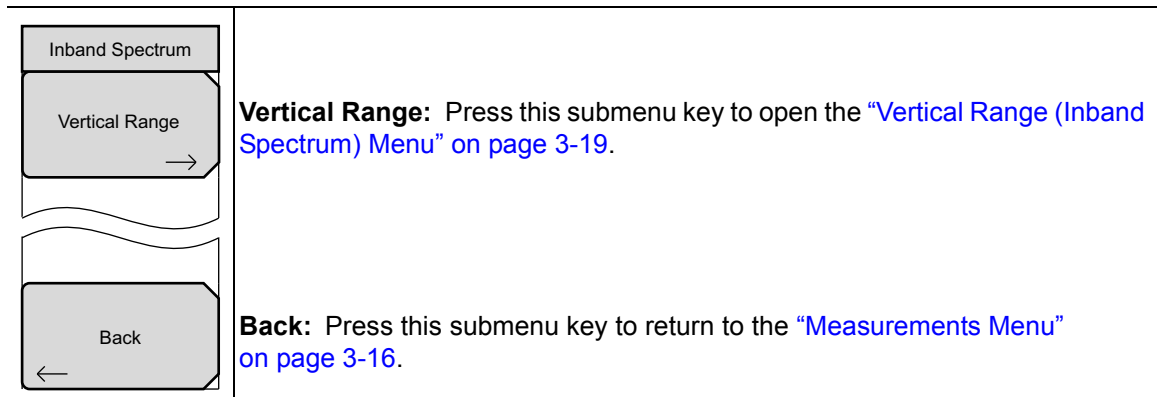


Figure 3-14. Inband Spectrum Menu

3-18 Vertical Range (Inband Spectrum) Menu

Press one of the four submenu keys in this menu to set the y-axis of the Inband Spectrum graph.

Key Sequence: **Measurements** > Inband Spectrum > Vertical Range

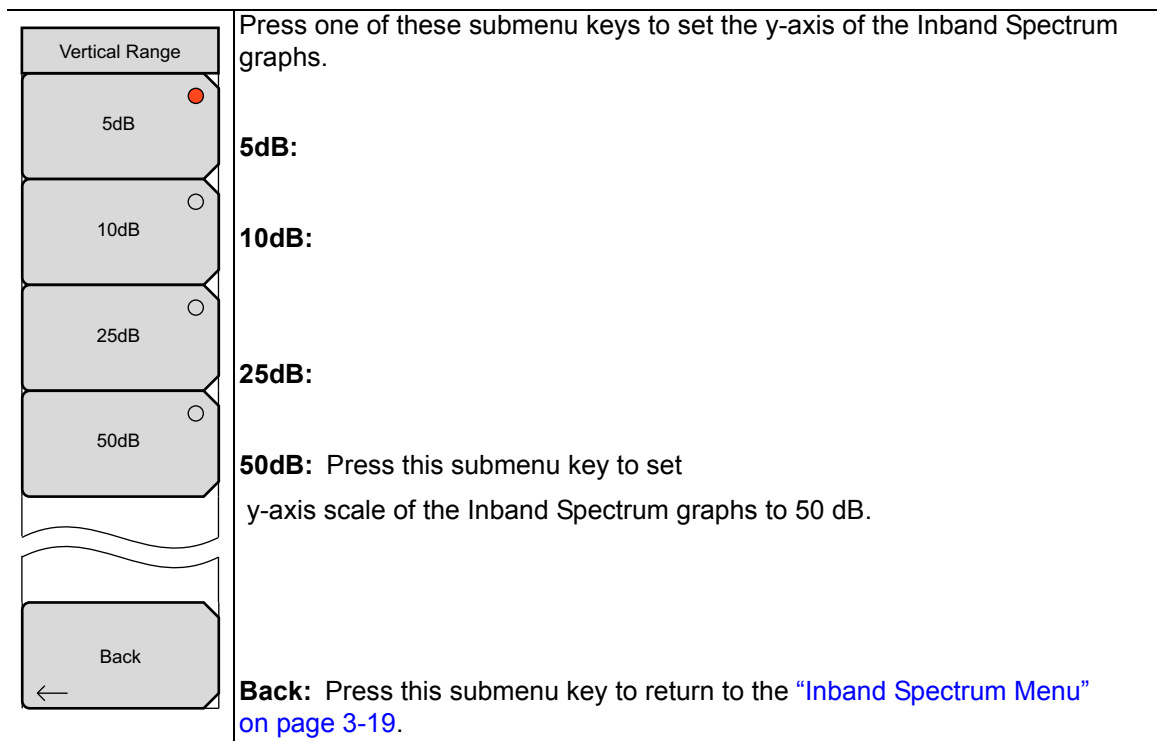


Figure 3-15. Vertical Range Menu (Inband Spectrum)

3-19 Marker Menu (Impulse Response)

This menu is displayed when the **Marker** main menu key is pressed while making measurements in the Impulse Response mode.

Key Sequence: **Marker**

Marker	<p>Marker Move Fix: Press this submenu key to toggle the Marker setting. The current setting, Move or Fix, is underlined on the submenu key. When Move is selected, the active marker is ready to be moved by using the Peak Search, Main to center of Zoom, or Path to center of Zoom submenu keys. When Fix is selected, the current location of the active marker is locked.</p>
Marker <u>Move</u> Fix	
Active Marker All <u>Zoom</u>	<p>Active Marker All Zoom: Press this submenu key to toggle the Active Marker setting. The current setting, All or Zoom, is underlined on the submenu key. When All is selected, the green rectangle marker turns on in the Impulse Response (All) graph. When Zoom is selected, the little green diamond marker turns on in the Impulse Response (Zoom) graph.</p>
Marker Mode <u>Normal</u> Zone	
Unit <u>dBμV/m</u> dB μ V	<p>Marker Mode Normal Zone: Press this submenu key to toggle the Marker Mode setting. The current setting, Normal or Zone, is underlined on the submenu key. This submenu key is displayed only when Active Marker is set to Zoom and is for use only with the Impulse Response (Zoom) graph. Normal selects the little green diamond marker for movement. Zone displays a green rectangle marker for movement.</p>
Peak Search	
Main to center of Zoom	<p>Unit dBμV/m dBμV: Press this submenu key to toggle the Unit setting. The current setting, dBμV/m or dBμV, is underlined on the submenu key. This measurement is displayed in the table under the Impulse Response (Zoom) graph, between Field Strength (dBμV/m) and Termination Voltage (dBμV) and is based on the unit selected.</p>
Path to center of Zoom	
	<p>Peak Search: Press this submenu key to move the selected Marker to the highest amplitude of the measured signal.</p> <p>Main to center of Zoom: Press this submenu key to move the rectangle marker in the Impulse Response (All) graph to the center of the sweep window.</p> <p>Path to center of Zoom: Press this submenu key to move the tiny green diamond marker in the Impulse Response (Zoom) graph to the center of the sweep window.</p>

Figure 3-16. Marker Menu (Impulse Response)

3-20 Marker Menu (Inband Spectrum)

This menu is displayed when the **Marker** main menu key is pressed while making measurements in the Inband Spectrum mode.

Key Sequence: **Marker**


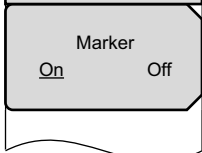
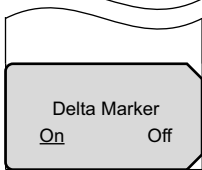
	<p>Marker On Off: Press this submenu key to toggle the main Marker setting On or Off. The current setting is underlined on the submenu key. When set to On (and when the Delta Marker is Off), this marker is displayed as a small green diamond in the Inband Spectrum graph.</p>
	<p>The frequency and amplitude that are displayed in the lower-right corner of the screen are absolute values that are associated with the marker.</p>
	<p>Delta Marker On Off: Press this submenu key to toggle the Delta Marker setting On or Off. The current setting is underlined on the submenu key. When Marker and Delta Marker are both set to On, the reference marker is replaced with a small green square, and the Delta Marker is displayed as a green diamond, which is originally located at exactly the same point at which the reference marker is located.</p>
	<p>Notice that the frequency and amplitude annotation that are initially displayed in the lower-right corner of the screen are 0 MHz and 0 dB. This is because this annotation corresponds to the Delta Marker position (diamond) relative to the fixed marker position (square), and the Delta Marker is originally placed exactly at the reference marker position.</p> <p>By turning the rotary knob, you can move the Delta Marker to a different location.</p>

Figure 3-17. Marker Menu (Inband Spectrum)

Chapter 4 — ISDB-T Signal Analyzer

(Option 30)

4-1 Introduction

Option 30 provides measurement capabilities for testing ISDB-T networks, which are terrestrial digital broadcast networks. Note that Option 9 (IQ Demodulation Hardware) may be required in your instrument in order to use Option 30. The ISDB-T Signal Analyzer includes seven types of measurements: Field Strength, Modulation Analysis, Spectrum Mask, Phase Noise, Spurious Emissions, BER measurements, and Spectrum Monitor.

Field Strength: Measures channel power and field strength.

Modulation Analysis: Measures modulation error ratio (MER), modulation wave frequency, sub-carrier MER, delay profile, and frequency response.

Spectrum Mask: Evaluates the input signal spectrum.

Phase Noise: Measures CW frequency and the local phase noise of the transmitter.

Spurious Emissions: Measures spurious elements and the interfering waves that affect the broadcast quality.

BER (Option 79): Measures Bit Error Rate, Packet Error Rate, Transmission Multiplexing Configuration Control (TMCC), MPEG TS Bit Rate, and Channel Power.

Spectrum Monitor: Displays the spectrum of the input signal.

After a test has been selected from the [“Meas Selection \(1/2\) Menu \(Custom and Easy\)”](#), choose one of three methods for setting up a measurement: **Batch**, **Easy**, or **Custom**. When either Custom Measurement mode or Easy Measurement mode has been selected, all measurements in the Meas Selection (1/2) menu are set up for that measurement mode. In Batch Measurement mode, a limited group of measurements are available (refer to [“Batch Measurement Setup” on page 4-9](#)).

Screen images of measurements, as shown in this document, are examples. The images on your instrument may differ in appearance.

The main menu keys in this instrument mode are:

Frequency/Level Meas Selection Meas Setup Execute Measure Save Files

For BER measurements, the **Execute Measure** main menu key becomes a **Start Measurement/Stop Measurement** key.

4-2 Instrument Connections

Attach the antenna to the connector labeled Spectrum Analyzer RF In on top of the instrument. [Figure 1-1 on page 1-3](#) is an example of an Anritsu handheld instrument. Refer to your User Guide for a description of the connectors on your instrument.

4-3 Digital Television Signal Analyzer Technology

Carrier modes, OFDM carriers, Guard Intervals and the FFT Start position are described in [Chapter 1, Section 1-6 “Digital Television Signal Analyzer Technology” on page 1-4](#).

4-4 Chapter Topics

This chapter is presented in three parts:

“ISDB-T Signal Analyzer Technology” on page 4-4

This section provides brief descriptions of ISDB-T Modes, Guard Intervals, and the FFT Start position.

“Quick Start Configuration, Setup, and Testing” on page 4-5

This section provides information for getting started with measurements when you are already familiar with using the ISDB-T Signal Analyzer on your instrument.

- A. **“Quick Start in All Modes” on page 4-5**
- B. **“Batch Measurement Setup” on page 4-9**
- C. **“Easy Measurement Setup” on page 4-15**
- D. **“Custom Measurement Setup” on page 4-20**

“ISDB-T Menus and Measurements for Custom and Easy” on page 4-55

This section provides the most detailed information for ISDB-T measurements. It includes explanations regarding the use of submenu keys and functions for all available menu choices.

4-5 ISDB-T Signal Analyzer Technology

Modes 1, 2, and 3

These three modes offer a strategy that is similar to the 2K, 4K, and 8K modes of DVB-T/H. In ISDB-T, these system modes provide different carrier spacing between OFDM carrier frequencies. The modes indicate bandwidth, carrier interval, and number of carriers in the OFDM symbols, as shown in [Table 4-1](#).

Table 4-1. ISDB-T Modes and Parameters

Transmission Parameter	Mode 1	Mode 2	Mode 3
Bandwidth	5.575 MHz	5.573 MHz	5.572 MHz
Carrier Interval	3.968 kHz	1.984 kHz	0.992 kHz
Number of Carriers	1405	2809	5617

The mode number and the fraction of the Effective Symbol (Data) that is used for a Guard Interval are both chosen by pressing the **Mode, GI** submenu key in the Meas Setup (2/2) menu (refer to [Figure 1-3 on page 1-8](#)). The Select Mode, GI list box contains the available choices. For example, selecting 3, 1/4 means that Mode 3 will be used and that the Guard Interval will be one-fourth the size of the effective symbol.

Guard Intervals

The mode number and the fraction of the Effective Symbol (Data) that is used for a Guard Interval are both chosen by pressing the **Mode, GI** submenu key in the Measurement Setup menu. The Select Mode, GI list box (refer to [Figure 4-1](#)) contains the available choices.

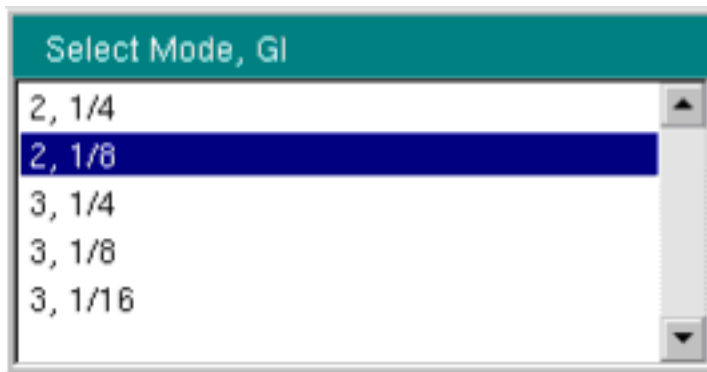


Figure 4-1. Select Mode, GI List Box

FFT Start

[Figure 1-3 on page 1-8](#) illustrates a Guard Interval that is one-fourth of the effective symbol. Note that it could also be one-eighth, or one-sixteenth of the length of the Effective Symbol. For additional information, refer to Section “[FFT Start](#)” on page 1-7.

4-6 Quick Start Configuration, Setup, and Testing

Use the following procedures to quickly prepare for all measurements by utilizing the built-in features of the instrument and the software.

Quick Start in All Modes

Antenna Setup

1. Attach the antenna to the Spectrum Analyzer RF In connector (refer to the User Guide for your instrument for connector identification and location).
2. Configure the instrument antenna:
 - a. Press the **Meas Selection** main menu key.
 - b. Press the Field Strength submenu key in the Meas Selection (1/2) menu.
 - c. Press the **Meas Setup** main menu key to open the Meas Setup menu.
 - d. Press the Antenna (Correction Level) submenu key to open the Select Antenna list box (refer to [Figure 4-2](#)).
 - e. Scroll through to the desired Anritsu antenna model number by using the **Up/Down** arrow keys or the rotary knob. Highlight the antenna model number, and then press **Enter**.

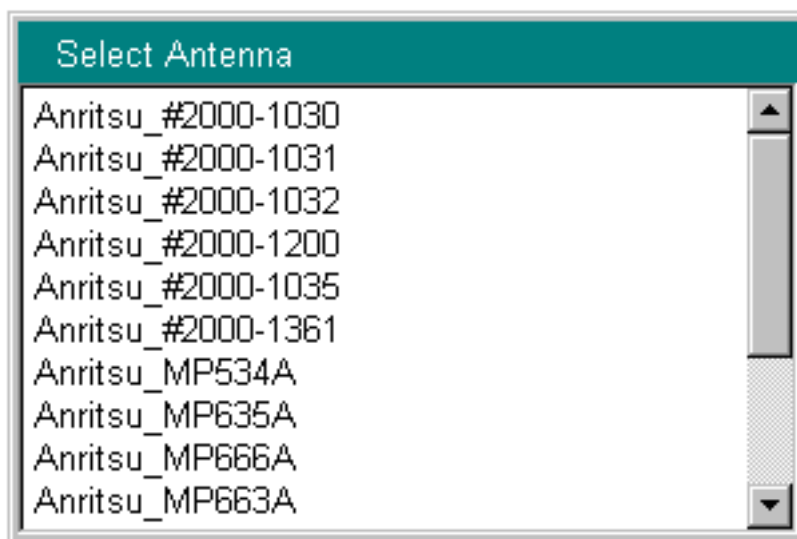


Figure 4-2. Select Antenna List Box

You can use Master Software Tools (MST) to update your antenna and coaxial cable lists. For directions about updating these lists, refer to the Master Software Tools documentation (available from www.anritsu.com).

Frequency and Reference Level Configurations

1. Press the **Frequency/Level** main menu key.
2. Configure the following parameters: Channel/Frequency, Bandwidth, Auto Reference Level, Reference Level, Pre Amp, and One-Seg.
 - a. Press the **Channel Map** submenu key to open the Select Channel Map list box.
 - b. Select one of the available choices, then press the **Enter** button.

If you selected **UHF** or **UHF (Brazil)**, then press the **Channel** submenu key, scroll through to the desired channel, highlight it, and press **Enter**. Continue at [Step 4](#).

If you selected **IF**, then the frequency is automatically set to 37.150000 MHz. Continue at [Step 4](#).

If you selected **None**, then continue at [Step 2 c](#) to configure the Frequency.
 - c. Press the **Frequency** submenu key to open the Frequency Editor dialog box. The menu changes to Units (Hz, kHz, MHz, GHz). The available frequency range step increments are displayed in the dialog box.
 - d. Scroll through to a desired frequency by using the **Up/Down** arrow keys or the rotary knob, and then press **Enter**. You can also type the frequency by using the number keypad and then pressing one of the submenu keys in the Units menu. Pressing the **Enter** key is the same as pressing the MHz submenu key. The frequency can be set from 35 MHz to 806 MHz.
3. Press the **Bandwidth** submenu key and select the desired bandwidth frequency, 6 MHz or 8 MHz. Note that the 8 MHz bandwidth should be selected only when Channel Map is set to None. It can be selected for the Field Strength, Modulation Analysis, and Spectrum Monitor measurements in the Custom setup procedure.
4. Press the **Auto Reference Level** submenu key to have the instrument set an optimum Reference level. To manually set a reference level, go to [Step 5](#).
5. Press the **Reference Level** submenu key to open the Reference Level Editor dialog box. Scroll through to the desired dBm level by using the **Up/Down** arrow keys or the rotary knob, and then press **Enter**. The dB increments vary depending upon the use of Pre Amp.
6. Press the **Pre Amp** submenu key to toggle the selection to the desired state, On or Off. The current state is underlined. Refer to the input level [Warning on page 4-69](#).
7. Press the **One-Seg** submenu key to toggle the selection to the desired state, On or Off. When this submenu key is toggled to On, the frequency response measurement is displayed for the center segment (the center channel of the 13 chosen channels). Refer to [Figure 4-15, “Modulation Analysis of Delay Profile, One-Segment” on page 4-33](#). Note that the One-Seg feature may be selected only when the Bandwidth is set to 6 MHz. It is used for Field Strength, Modulation Analysis, BER, or Spectrum Monitor measurements.

4-7 Batch, Easy, and Custom Setup Procedures

Measurements Setups Using Batch, Easy, and Custom Procedures

While in Easy or Custom mode, the three mode submenu keys for choosing Batch, Easy, and Custom are displayed by pressing the **Meas Selection** main menu key then the **More** submenu key, which opens the Meas Selection (2/2) menu. The active mode has a submenu key with a red circle, which can be seen as the Field Strength selection in Figure 4-3. While in Batch mode, Batch, Easy, and Custom are the only submenu keys that are displayed in the Meas Selection menu. Refer to Figure 4-4.

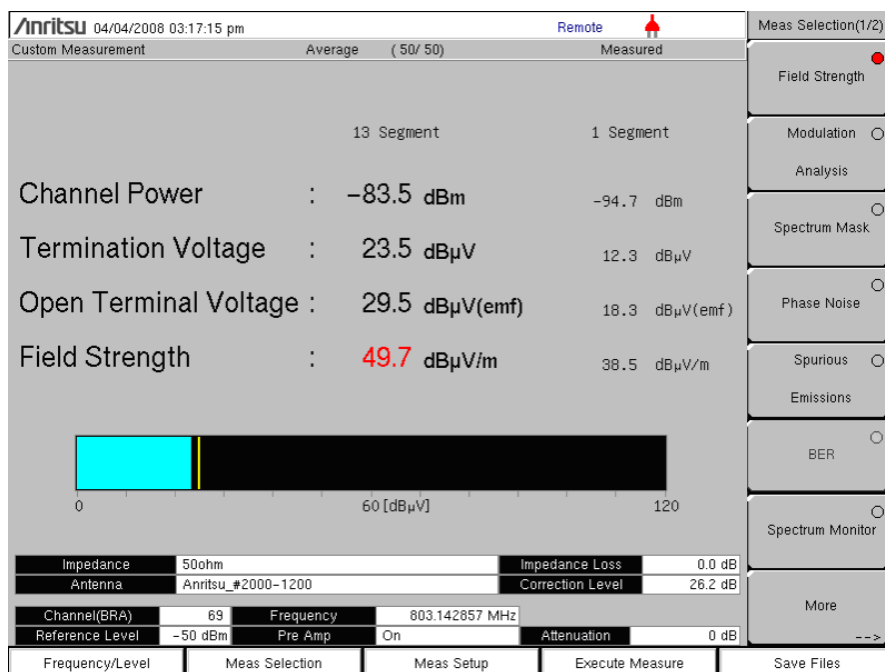


Figure 4-3. Measurement Screen and Meas Selection (1/2) Menu

Following is a list of the major tests and the related parameters that are tested.

Field Strength: Measures channel power and field strength.

Modulation Analysis: Measures MER, modulation wave frequency, sub-carrier MER, delay profile, and frequency response.

Spectrum Mask: Evaluates the input signal spectrum.

Phase Noise: Measures CW frequency and the local phase noise of the transmitter.

Spurious Emissions: Measures spurious elements and the interfering waves that affect the broadcast quality.

BER: Measures Bit Error Rate, Packet Error Rate, Transmission Multiplexing Configuration Control (TMCC), MPEG TS Bit Rate, and Channel Power.

Spectrum Monitor: Displays the spectrum of the input signal.

After a test has been selected, choose one of three methods for setting up a measurement: **Batch**, **Easy**, or **Custom**. When a measurement setup mode has been selected, all measurements in the Meas Selection (1/2) menu are set up for that measurement mode.

In **Batch** mode (refer to [Table 4-2](#) through [Table 4-5](#)), field strength, channel power, modulation analysis, and spectrum mask of up to 10 broadcast channels can be measured in series. CW frequency, phase noise, BER, and spurious emissions are not measured.

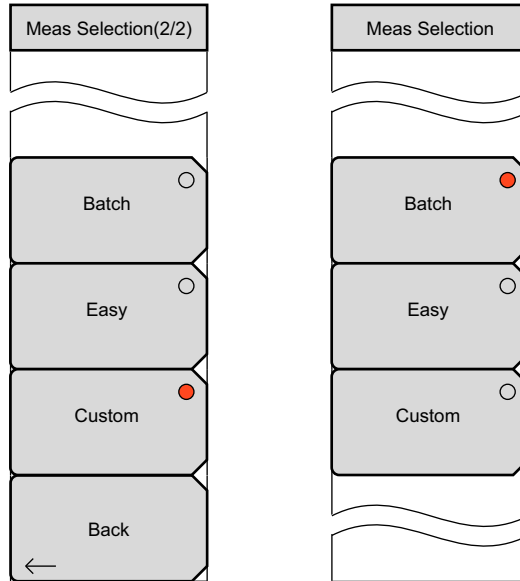


Figure 4-4. Measurement Selection Menus

4-8 Batch Measurement Setup

Batch measurement mode allows you the option of running multiple tests for multiple channels. Batch mode setup consists of a combination of minimal setup procedures and default measurement parameters. You are allowed to select channels from either the UHF or UHF (Brazil) channel maps. If you select IF or None, then the channel map is automatically set to UHF.

Batch measurement mode is not available for BER measurements.

Review [Table 4-2](#), [Table 4-3](#), [Table 4-4](#), and [Table 4-5](#) in the section titled “[Batch Measurements](#)” on [page 4-13](#) for specific measurement settings. In Batch measurement mode, Spectrum Mask, Phase Noise, and Spectrum Monitor measurements are completely preset, with no parameters that need to be set manually.

Batch Measurement Preparation

Follow this procedure to set up for Batch Measurement mode when your instrument is currently in either Easy Measurement mode or Custom Measurement mode.

1. Press the **Frequency/Level** main menu key and then press the **Channel Map** submenu key to open the Select Channel Map list box.
2. Select UHF or UHF (Brazil) and then press **Enter**.
3. Press the **Meas Selection** main menu key, then press the **More** submenu key.
4. Press the **Batch** submenu key. A warning window opens. Press **Enter** to continue or **Esc** to abort.

5. The Batch Measurement configuration window is displayed, and the “[Batch Measurement Setup Menu](#)” is displayed. Note that no **Frequency/Level** main menu key and no **Save Files** main menu key are available.

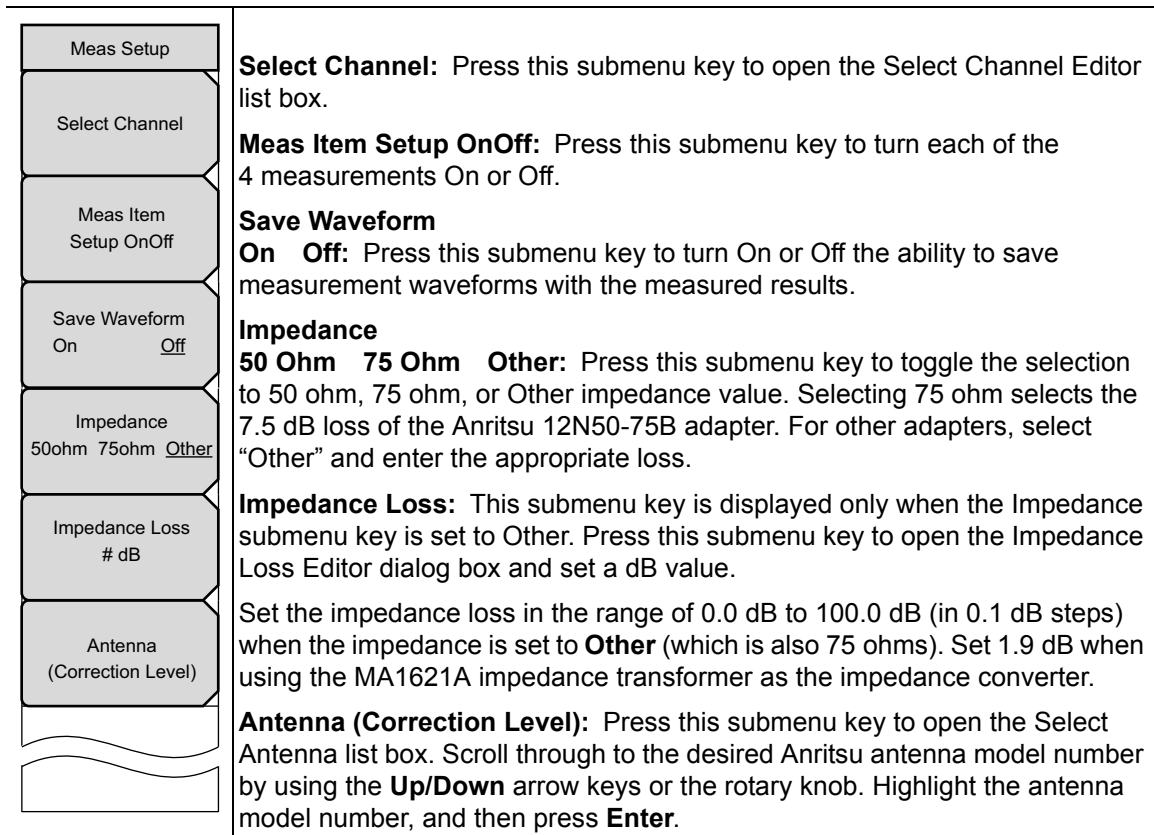


Figure 4-5. Batch Measurement Setup Menu

Batch Setup

1. Press the **Select Channel** submenu key to open the Select Channel Editor dialog box.

The Select Channel Editor dialog box displays the available channels (**Channel** column) and a list of channels that have been selected for measurement (**Meas Object** column). Refer to [Figure 4-7](#).

- a. Use the **Up/Down** arrow keys or the rotary knob to scroll through the list of channel numbers. Highlight a desired channel number and then press the **Add Channel to Meas Object** submenu key. Repeat this step until the desired channels are listed in the **Meas Object** column of the Select Channel Editor dialog box.

If undesired channel numbers are present in the **Meas Object** list, then highlight the desired channel numbers in the **Channel** list and press the **Delete Channel from Meas Object** submenu key. You can also press the **Delete All Channels from Meas Object** submenu key.

- b. Press **Enter** when you are done selecting channels.

Note

Up to ten channels can be selected for batch measurements. The **Add Channel to Meas Object** submenu key does not respond after ten channels are included in the **Meas Object** list.

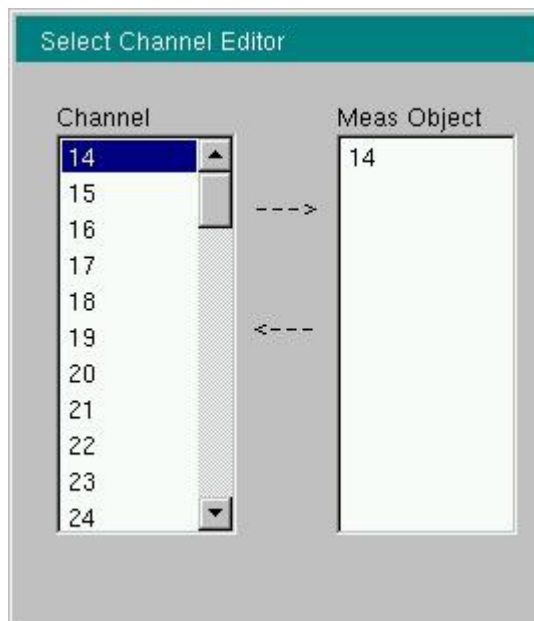


Figure 4-6. Select Channel Editor Dialog Box

Batch Setup – Select Channel Menu

	<p>Add Channel to Meas Object: Press this submenu key to add the highlighted channel number (in the Channel column) to the Meas Object column list.</p> <p>Delete Channel from Meas Object: Press this submenu key to delete the highlighted channel number (in the Channel column) from the list in the Meas Object column.</p> <p>Delete All Channels from Meas Object: Press this submenu key to delete all of the channels from the Meas Object column.</p>
--	--

Figure 4-7. Select Channel Menu (Batch Measurement Mode)

2. Select the measurements that are to be performed on the selected channels.
 - a. Use the **Up/Down** or **Left/Right** arrow keys or the rotary knob to move the green cursor to the desired measurement (displayed at the top of the measurement screen): Field Strength, CH Power, Modulation Analysis, or Spectrum Mask. You can select any or all of these four measurements.
 - b. Press the **Meas Item Setup OnOff** submenu key to turn On or Off a highlighted measurement. A check mark in the box to the left of the measurement name indicates that the measurement is selected.
3. To save the measurement waveforms of the test, press the **Save Waveform** submenu key (if necessary) so that **On** is underlined. Measurement waveforms are saved to file with the extension `_GRP.CSV`.
4. Press the **Impedance** submenu key to toggle through the 3 settings. Select one of the three parameters: **50 ohm**, **75 ohm**, or **Other**. The current selection is underlined.
 - a. If **Other** is selected, then the additional **Impedance Loss** submenu key is displayed.
 - b. To configure the impedance loss, press the **Impedance Loss** submenu key and use the **Up/Down** arrow keys, the rotary knob, or the numeric keypad to set a value.
 - c. The **Impedance Loss Editor** dialog box and the **Units** menu are displayed. When using the numeric keypad, enter a value and then press the **dB** submenu key or press **Enter** to set the value.

The impedance loss setting range is 0 dB to 100 dB in 0.1 dB increments. The **Up/Down** arrow keys change the impedance loss value in 1 dB steps. The rotary knob changes the impedance loss value in 0.1 dB steps.

5. Press the Antenna (Correction Level) submenu key to open the Select Antenna list box. Scroll through to the desired Anritsu antenna model number by using the **Up/Down** arrow keys or the rotary knob. When the desired Anritsu antenna model number is highlighted, press **Enter**.

Note Impedance, impedance loss, and antenna model number are displayed at the bottom of the Batch Measurement configuration display.

6. Press the **Execute Measure** main menu key to begin testing. While the batch measurement is being completed, the **Execute Measure** main menu key is replaced by a **Stop Measure** main menu key. Use the **Stop Measure** main menu key to abort the batch measurement.

As test measurements are being made, “Measuring” is displayed at the top of the measurement display. After the last selected measurement is complete, the Spectrum Monitor measurement runs automatically. The Batch test is complete after the Spectrum Monitor measurement is completed.

Batch Measurements

Field Strength, Channel Power, Modulation Analysis, and Spectrum Mask of up to 10 broadcast channels can be measured in series. Channel Power is measured during Field Strength measurements.

CW Frequency, Phase Noise, and Spurious Emissions are not measured.

[Table 4-2](#), [Table 4-3](#), [Table 4-4](#), and [Table 4-5](#) provide initial values of measurement selections.

When the Channel Map selection is UHF, a screen message displays “Batch Measurement”. When the Channel Map selection is UHF (Brazil), a screen message displays “Batch Measurement (Brazil)”.

Table 4-2. Common Items for All Batch Mode Measurements

Item	Initial Value
Channel Map	UHF or UHF (Brazil)
Channel ^a	13 (UHF) or 14 (UHF (Brazil))
Frequency	UHF or UHF (Brazil)
Reference Level	Automatically adjusted before measurement
Preamplifier	Automatically adjusted before measurement
Measure Selection ^a	All the items of Field Strength, Channel Power, Modulation Analysis, and Spectrum Mask are selected.

a. Setting can be changed while in Batch Measurement mode.

Table 4-3. Field Strength Measurement Items for Batch Mode

Item	Initial Value
Measurement Mode	Average count mode only
Average count	50 times
Impedance ^a	50 ohm
Impedance Loss	0.0 dB
Antenna (Correction Level)	Value calculated from the table of antenna correction factors for the first antenna that is listed in the Select Antenna list box and also from the frequency

a.Setting can be changed while in Batch Measurement mode.

Table 4-4. Modulation Analysis Measurement Items for Batch Mode

Item	Initial Value
Measurement Mode	Only continuous measurement (cannot be modified)
Average count	Unavailable (continuous measurement only)
Display switch between Constellation and Delay Profile	Constellation
Mode, Guard Interval	Automatic Detection before measurement
TMCC Information	Automatic Detection before measurement
FFT Start Position	2/8 Fixed
Spectrum Reverse	Off only
Select Zoom	No zoom function
Zoom	No zoom function
Delay Profile Vertical Range	50 dB (cannot be modified)
Frequency Response Vertical Range	50 dB (cannot be modified)
Marker	No marker function.

Table 4-5. Spectrum Mask Measurement Items for Batch Mode

Item	Initial Value
Standard Line	Standard B (P > 2.5 W) (cannot be modified)
Floor reduction	On
Marker	No marker function

4-9 Easy Measurement Setup

Easy setup consists of a combination of minimal setup procedures and default measurement parameters. The reference level is automatically set. Mode, guard interval, and TMCC data are automatically detected and used for setting initial measurement values. For specific measurement settings, review [Table 4-6](#) through [Table 4-11](#) in the section titled “[Easy Measurement Parameters](#)” on [page 4-17](#). Spectrum Mask, Phase Noise, BER, and Spectrum Monitor measurements are completely preset, with no parameters that need to be set manually. For these four Easy Measurement mode measurements, the Meas Setup menu has no submenu keys.

General Easy Setup

1. Complete the antenna setup and the frequency and reference level configurations that are described in [Section 4-6 “Quick Start Configuration, Setup, and Testing”](#) on [page 4-5](#).
2. Press the **Meas Selection** main menu key, then press the **More** submenu key.
3. Press the **Easy** submenu key. A warning dialog box opens. Press **Enter** to continue, or press **Esc** to abort.
4. Press the **Back** submenu key to return to the Meas Selection (1/2) menu.
5. Select the desired measurement:
 - a. For Phase Noise, BER, or Spectrum Monitor measurements, press the desired submenu key. No further measurement setup is necessary, and the Meas Setup menu has no available submenu keys. Press either the **Execute Measure** or **Start Measurement** main menu key to begin testing.
 - b. For Field Strength, Modulation Analysis, Spectrum Mask, or Spurious Emissions, continue the setup by using one of the following measurement setup procedures:

Field Strength Measurement Setup

1. Press the Field Strength submenu key, then press the **Meas Setup** main menu key. In Easy Measurement mode, the Meas Setup menu has only one level with either 2 or 3 submenu keys, as described in the following steps.
2. Press the **Impedance** submenu key to select 50 ohm, 75 ohm, or Other. The selected setting is underlined. If **Other** is selected, then the **Impedance Loss** submenu key is also displayed in the menu. Press **Impedance Loss** to open the Impedance Loss Editor dialog box. Set the impedance to the desired value and press **Enter**.
3. Press the **Antenna (Correction Level)** submenu key to open the Select Antenna list box. Scroll to the desired Anritsu antenna model number, and when it is highlighted, press the **Enter** key.
4. Press the **Execute Measure** main menu key to begin testing.

Modulation Analysis Setup

1. Press the Modulation Analysis submenu key.
2. Press the **Meas Setup** main menu key. In Easy Measurement mode, the Meas Setup menu has only one level with either 2 or 3 submenu keys, as described in the following steps.
3. Press the desired Modulation measurement submenu key: **Constellation** or **Delay Profile**. The active measurement key has a red circle. If you activate **Constellation**, then the Sub-carrier MER submenu key is also displayed.
 - a. To view the constellation graphs of Layer C and TMCC, press the Sub-carrier MER submenu key so that **Off** is underlined.
 - b. To view the Sub-carrier MER graph, press the Sub-carrier MER submenu key so that **On** is underlined.
4. Press the **Execute Measure** main menu key to begin testing.

Spectrum Mask Setup

The Spectrum Mask setup is available when channel map is set to UHF (Brazil).

1. Press the Spectrum Mask submenu key.
2. Press the **Meas Setup** main menu key. In Easy Measurement mode, only the Filter Selection submenu key is displayed in the Meas Setup menu.
3. Press the Filter Selection submenu key to open the Select Filter dialog box. Use the **Up/Down** arrow keys or the rotary knob to scroll to the desired selection and then press **Enter**. Choose from Default or three user selections.
4. Press the **Execute Measure** main menu key to begin testing.

Spurious Emissions Setup

When entering the Spurious Emissions measurement mode, you may receive the following message:

```
<< Information >>
Set HPF to RF terminal.
Press ENTER to continue.
```

This message is advising you to insert a High Pass Filter (HPF) at the RF In port of your instrument. The purpose is to filter out the transmitted signal so that spurious emissions can be detected with greater sensitivity.

1. Press the Spurious Emissions submenu key.
2. Press the **Meas Setup** main menu key. In Easy Measurement mode (and Custom Measurement mode), only the HPF Loss submenu key is displayed in the Meas Setup menu.
3. Press the HPF Loss submenu key to open the HPF Loss dialog box. Use the **Up/Down** arrow keys or the rotary knob to scroll to the desired value and then press **Enter**. You may also use the numeric keypad to enter a value and then press either the **dB** submenu key or the **Enter** key. The HPF Loss step increments and range are listed in the dialog box.
4. Press the **Execute Measure** main menu key to begin testing.

Save the Test Results

Save measurements to file by pressing the **Save Files** main menu key. Refer to the section, [“Saving the Measurement Results” on page 4-52](#) for more information regarding saving files.

Easy Measurement Parameters

In Easy Mode (refer to [Table 4-6](#) through [Table 4-11](#)), the parameters are automatically detected when measurement is performed. You do not need to set the measurement parameters other than basic setup. The following tables list parameter settings for the easy operation setup testing.

Table 4-6. Common Items for All Easy Mode Measurements

Item	Initial Value
Channel Map	UHF or UHF (Brazil)
Channel	13 (UHF) or 14 (UHF(Brazil))
Frequency	473.142857 MHz
Reference Level	Automatically adjusted before measurement
Preamplifier	Automatically adjusted before measurement
Measure Selection	Field strength

Table 4-7. Field Strength Measurement Items for Easy Mode

Item	Initial Value
Measurement Mode	Only continuous measurement (cannot be modified)
Average count	Unavailable (only for continuous measurement)
Impedance	50 ohm
Impedance Loss	0.0 dB
Antenna (Correction Level)	Value calculated from the table of antenna correction factors for the first antenna that is listed in the Select Antenna list box and also from the frequency

Table 4-8. Modulation Analysis Measurement Items for Easy Mode

Item	Initial Value
Measurement Mode	Only continuous measurement (cannot be modified)
Average count	Unavailable (only for continuous measurement)
Display switch between Constellation and Delay Profile	Constellation
Mode, GI	Automatic Detection before measurement
TMCC Information	Automatic Detection before measurement
FFT Start	2/8 Fixed
Spectrum Reverse	Depends on channel map setting
Select Zoom	No zoom function
Zoom	No zoom function
Delay Profile Vertical Range	50 dB fixed (cannot be modified)
Frequency Response Vertical Range	50 dB fixed (cannot be modified)
Marker	No marker function.
Measurement Mode	Only continuous measurement (cannot be modified)

Table 4-9. Spectrum Mask Measurement Items for Easy Mode

Item	Initial Value
Standard Line	UHF Standard B ($P > 2.5$ W) (cannot be modified) UHF (Brazil) Critical (cannot be modified)
Floor reduction	On
Marker	No marker function

Table 4-10. CW Frequency/Phase Noise Measurement Items for Easy Mode

Item	Initial Value
Meas Mode	Only for continuous measurement (cannot be modified)
Marker	No marker function
Integration	No Integration

Table 4-11. Spurious Emissions Measurement Items for Easy Mode

Item	Initial Value
HPF Loss	0.0 dB

Table 4-12. BER Measurement Items for Easy Mode

Item	Initial Value
Meas Mode	Only for continuous measurement (cannot be modified)
Spectrum Reverse	If Channel Map = IF, then initial value is On (cannot be modified) All other conditions, initial value is Off (cannot be modified)

Table 4-13. Spectrum Monitor Measurement Items for Easy Mode

Item	Initial Value
Meas Mode	Only for continuous measurement (cannot be modified)
Impedance	50 ohm
Antenna (Correction Level)	Value calculated from the table of antenna correction factors for the first antenna that is listed in the Select Antenna list box, and also from the frequency

4-10 Custom Measurement Setup

Custom Measurement mode setup provides manual access to all available instrument functions and settings. Optional values for all of the measurement parameters can be set.

General Setup Procedure

1. Complete the antenna setup and the frequency and reference level configurations that are described in [Section 4-6 “Quick Start Configuration, Setup, and Testing” on page 4-5](#).
2. Press the **Meas Selection** main menu key, then press the **More** submenu key.
3. Press the **Custom** submenu key, then press the **Back** submenu key.

4-11 Field Strength Measurement, Custom

1. In the Meas Selection (1/2) menu, press the **Field Strength** submenu key.
2. Press the **Meas Setup** main menu key to open the Meas Setup menu.
Configure the parameters as desired, including **Meas Mode** and **Impedance**.
3. Press the **Meas Mode** submenu key to open the Select Meas Mode list box.
4. Use the **Up/Down** arrow keys or the rotary knob to scroll through the list of measurement modes. Choose from: **Single**, **Continuous**, **Average**, **Moving Average**, and **Max Hold**. When the desired measurement mode is highlighted, press **Enter**. If **Average** or **Moving Average** is selected, then set up **Average Count** ([Step 4a](#), next).

After the measurement mode is selected (and **Average Count** is set, if desired), configure **Impedance** ([Step 5](#)).

- a. Press the **Average Count** submenu key to open the **Average Count Editor** edit box. The available range is 1 to 100.
 - b. Use the **Up/Down** arrow keys, the rotary knob, or the numeric keypad to set a value. Scroll to the desired number count or enter the value, then press **Enter**.
5. Press the **Impedance** submenu key to toggle to one of the three parameters: **50 ohm**, **75 ohm**, or **Other**.
 - a. If **Other** is selected, then the additional **Impedance Loss** submenu key is displayed.
 - b. To configure the impedance loss, press the **Impedance Loss** submenu key to display the **Impedance Loss Editor** dialog box and the **Units** menu,
 - c. Use the **Up/Down** arrow keys, the rotary knob, or the numeric keypad to set a value. When using the numeric keypad, enter a value and press the **dB** submenu key or press **Enter** to set the value.

The impedance loss setting range is 0 dB to 100 dB in 0.1 dB increments. The **Up/Down** arrow keys change the impedance loss value in 1 dB steps. The rotary knob changes the impedance loss value in 0.1 dB steps.
 6. Press the **Antenna (Correction Level)** submenu key to open the **Select Antenna** list box. Scroll to the desired Anritsu antenna model number, and when it is highlighted, press the **Enter** key.

- Press the **Execute Measure** main menu key to begin testing.

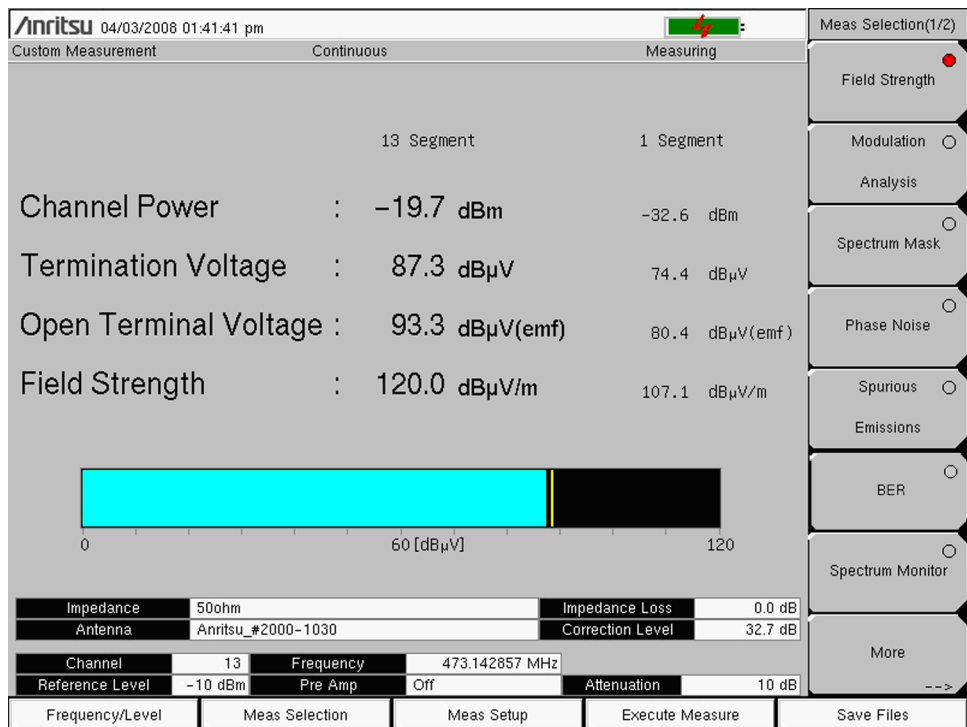


Figure 4-8. Field Strength Measurement Screen

- To save the test results, press the **Save Files** main menu key. Refer to the section, [“Saving the Measurement Results”](#) on page 4-52 for more information regarding saving files.

4-12 Modulation Analysis, Custom

When setting up the instrument for Modulation Analysis (whether viewing data in Constellation or Delay Profile display), consider the following basic measurement setup. Begin detecting a signal by setting the frequency.

General Setup

Test Selection:

1. Press the **Meas Selection** main menu key.
2. For modulation analysis, press the Modulation Analysis submenu key.

General Test Setup:

1. Press the **Frequency/Level** main menu key.
2. Next, choose a Channel (this automatically determines a frequency), or press Channel Map and choose “None”. If you choose “None”, then the second submenu key, Channel, is removed, and the third submenu key, Frequency, is displayed.

After setting the frequency, press the **Bandwidth** submenu key to select either 6 MHz or 8 MHz bandwidth. Refer to [Figure 4-30 on page 4-56](#) for a comparison of the **Frequency/Level** submenu keys that are displayed for different Channel Map selections.

3. After a channel (or None) is selected, the most convenient setup is available by pressing **Auto Reference Level**. You can also use the **Reference Level** submenu key to set the level manually. The Reference Level Editor dialog box displays the available range and the step value. Use the **Up/Down** arrow keys or the rotary knob and then press **Enter**.
4. With **Meas Selection** set to Modulation Analysis, press the **Meas Setup** main menu key to open the Meas Setup (1/2) menu. Then press the **Detect Parameter** submenu key to allow automatic setup of the top 2 settings in the Meas Setup (2/2) menu: Mode, GI and TMCC Information.

Use the **Constellation** and **Delay Profile** submenu keys to select the measurement to be displayed. You can manually set the modulation parameters, such as Mode, GI and TMCC, if you know the settings. Otherwise, you can use the **Detect Parameter** submenu key to have your instrument detect these parameter settings from the input signal.

Custom Modulation Analysis

Test Setup:

Configure the parameters as desired: Meas Mode, Detect Parameter, Constellation or Delay Profile, and Sub-carrier MER.

Selecting either Constellation or Delay Profile determines the type of modulation analysis to be made and the subsequent Meas Setup (2/2) menus that are available for configuration when you press the More submenu key.

1. Press the Meas Mode submenu key to open the Select Meas Mode list box.
2. Use the **Up/Down** arrow keys or the rotary knob to highlight the desired measurement mode and then press **Enter**. Choose from: Single, Continuous, Average, Moving Average, and Overwrite. Overwrite is available only for Constellation measurement display (refer to [Step 4 on page 4-28](#)), and is not displayed in the Select Meas Mode list box for the Delay Profile measurement display.

If Average or Moving Average is selected, then the Average Count submenu key is added to the menu. When the measurement mode is selected (and Average Count is set, if desired), continue to configure the modulation parameters at [Step 3](#).

- a. Press the Average Count submenu key to open the Average Count Editor edit box. The available range is 1 to 100.
 - b. Use the **Up/Down** arrow keys, the rotary knob, or the numeric keypad to set a value. Scroll to the desired number count or enter the value, then press **Enter**.
3. Press the Detect Parameter submenu key to automatically detect the Hierarchy, Modulation, and Mode, GI parameters. Refer to [Section 1-6 “Digital Television Signal Analyzer Technology” on page 1-4](#).
 4. To continue with the measurement configuration, press either the Constellation submenu key or the Delay Profile submenu key, then press the More submenu key to open the Meas Setup (2/2) menu.

In Modulation Analysis mode, four Meas Setup (2/2) menu submenu keys are common to both Constellation and Delay Profile measurements: Mode, GI, TMCC Information, FFT Start, and Spectrum Reverse. The other submenu keys are specific to each measurement type.

Common Measurement Setup Parameters:

5. Configure the following general modulation parameters as desired: Mode, GI, TMCC Information, FFT Start, and Spectrum Reverse.
6. Press the Mode, GI submenu key to open the Select Mode, GI list box.
7. Use the **Up/Down** arrow keys or the rotary knob to highlight the desired parameter, and then press **Enter**.
8. Press the TMCC Information submenu key to open the TMCC Information Editor dialog box and the TMCC Information menu (example shown in [Figure 4-9](#), your instrument image may differ).

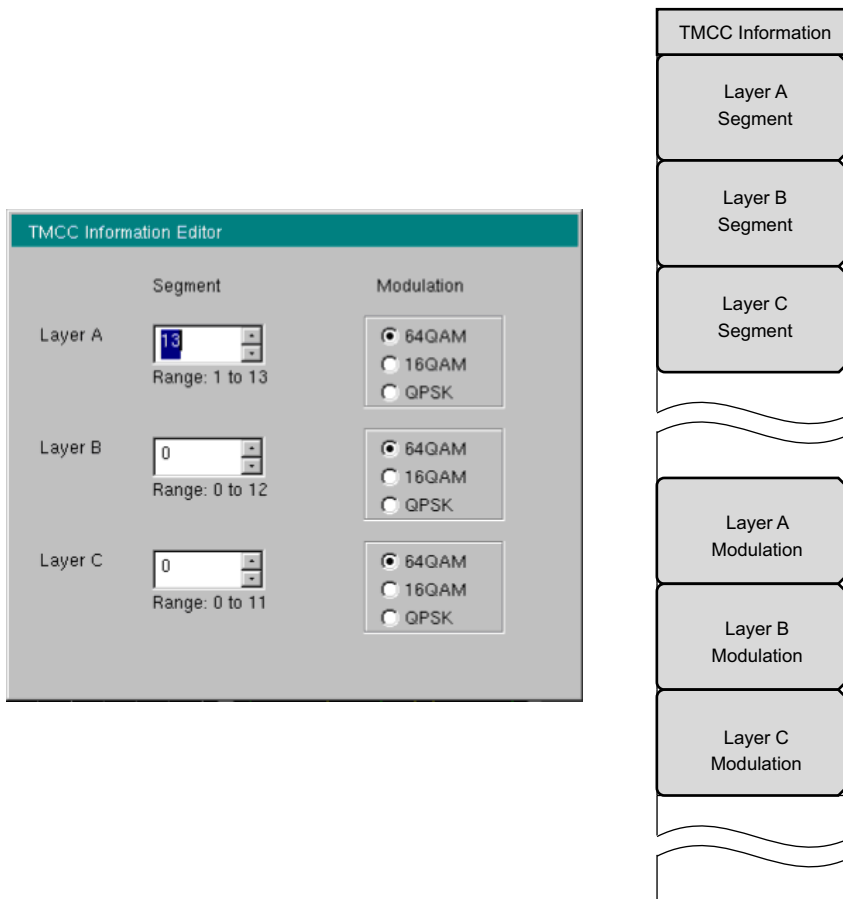


Figure 4-9. TMCC Information Editor Edit Box

TMCC Information Editor:

When the TMCC Information Editor dialog box opens, the Segment value for Layer A is highlighted. To set a specific layer, press one of the submenu keys: **Layer A Segment**, **Layer B Segment**, or **Layer C Segment**. In the active edit box, you can change the Segment value by using the numeric keypad to enter a segment number, or by using the **Up/Down** arrow keys or the rotary knob.

The sum of segment values for all 3 layers must add to 13. The range of segment values for each layer is displayed below the Segment edit box of each layer.

The Modulation types for each layer are indicated by the option buttons that are adjacent to the three options: 64QAM, 16QAM, and QPSK. Set a layer modulation by pressing its submenu key (**Layer A Modulation**, **Layer B Modulation**, or **Layer C Modulation**). Each press of the submenu key toggles the setting to the next modulation type.

9. Set the layer segment values and the modulation types for all 3 layers.

10. Press **Enter** to close the TMCC Information Editor dialog box and return to the Meas Setup (2/2) menu.

A message is displayed at the bottom of the TMCC Information Editor dialog box if the "Total of segments is not 13."

Press **Esc** at any time to abort the settings and return to the Meas Setup (2/2) menu.

11. Press the FFT Start submenu key to open the Select FFT Start list box.
12. Use the **Up/Down** arrow keys or the rotary knob to select an FFT Start value, then press **Enter**. Or press **Esc** to abort and return to the Meas Setup (2/2) menu.
13. Press the Spectrum Reverse submenu key to toggle the measurement feature On or Off. The active state is underlined.

Constellation Configuration:

When Constellation is selected, the Meas Setup (1/2) menu includes the mode-specific submenu key Sub-carrier MER, and the Meas Setup (2/2) menu includes two mode-specific submenu keys: Zoom and Marker. The Marker submenu key is displayed only when Sub-carrier MER is On.

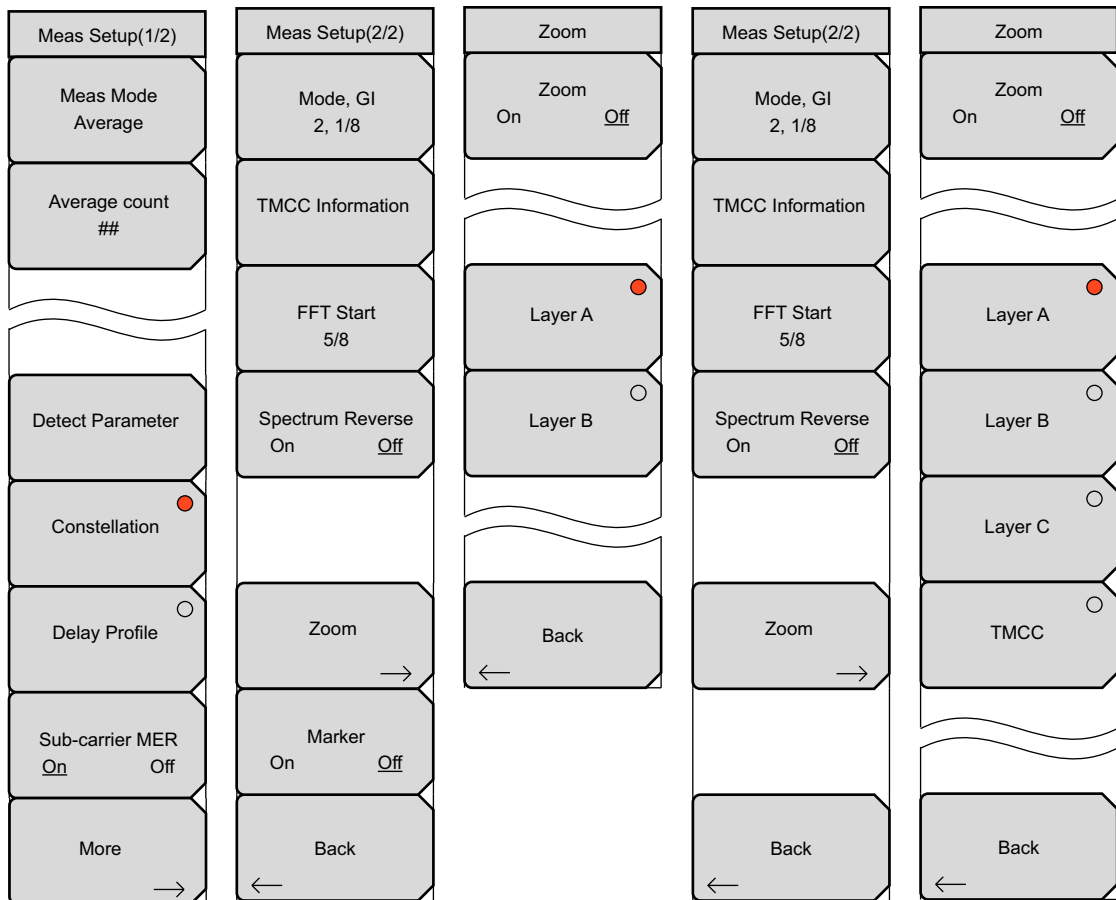


Figure 4-10. Constellation Setup and Zoom Menus

Making a Measurement:

When the measurement mode is set to Overwrite, the Sub-carrier MER and Zoom submenu keys are not available. Continue at [Step 4 on page 4-28](#).

1. Press the Sub-carrier MER submenu key to toggle the setting to On or Off.
2. Press the More submenu key to open the Meas Setup (2/2) menu.
3. Press the Zoom submenu key to open the Zoom menu. The Zoom function works together with the setting of the Sub-carrier MER submenu key. Configure the Constellation measurement according to the following choices:

Sub-carrier MER is On:

Refer to [Figure 4-10](#). In the Meas Menu (2/2) menu, the Marker submenu key is displayed. In the Zoom menu, Only Layer A and Layer B submenu keys are displayed.

When Zoom is set to Off, three graphs are displayed: Layer A constellation, Layer B constellation, and Sub-carrier MER. The active submenu key, shown with the red dot, highlights the associated layer graph in green.

- A. With Zoom set to Off and Marker toggled to On, use the rotary knob to move the marker to the desired frequency in the Sub-carrier MER graph.
- B. When Zoom is set to On, the selected graph is enlarged, and the other layer graph and the Sub-carrier MER graph are not displayed. Press the desired Layer A or Layer B submenu key to display the associated graph.

Sub-carrier MER is Off:

Refer to [Figure 4-10](#). In the Meas Menu (2/2) menu, the Marker submenu key is not displayed. In the Zoom menu, the Layer A, Layer B, Layer C, and TMCC submenu keys are displayed. The active submenu key, shown with the red dot, highlights the associated graph in green. No marker function is available.

- A. Press the Zoom submenu key to toggle Zoom On or Off.

When Zoom is set to Off, four small graphs are displayed, one for each layer and one for TMCC. The active submenu key, shown with the red dot, highlights the associated graph in green.

When Zoom is set to On, the selected graph (submenu key with red dot) is enlarged.

- B. To change the displayed (or highlighted) graph, Press the desired submenu key.

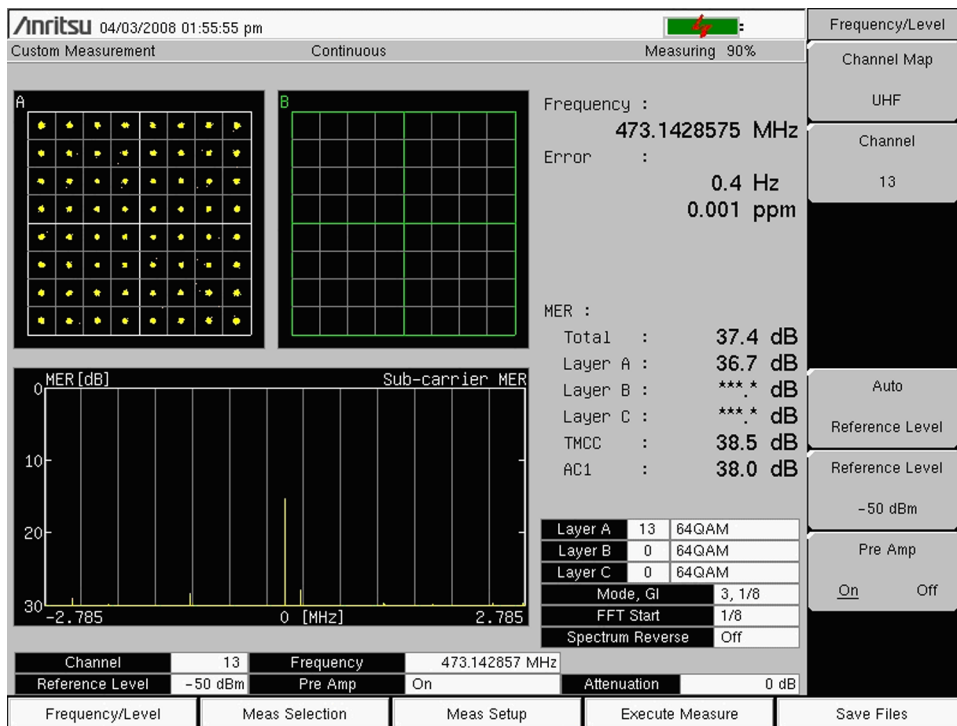


Figure 4-11. Modulation Measurement Screen – Constellation Display

Figure 4-11 illustrates Layer A and Layer B Constellation graphs and a Sub-carrier MER graph. Your instrument image may differ.

4. When Meas Mode is set to Overwrite, use the Detect Parameter submenu key for automatic detection, or press the More submenu key to open the Meas Setup (2/2) menu and manually configure Mode, GI, TMCC Information, FFT Start, and Spectrum Reverse (On or Off).
5. Press the **Execute Measure** main menu key to begin testing.
6. Press the **Save Files** main menu key to save measurements to file. Refer to the section, [“Saving the Measurement Results” on page 4-52](#) for more information regarding saving files

Delay Profile Configuration

Refer to [Figure 4-12](#). In this configuration, 1 mode-specific submenu key is displayed in the Meas Setup (1/2) menu: 0 μ s Position. Three mode-specific submenu keys are displayed in the Meas Setup (2/2) menu: Delay Profile Vertical Range, Freq Response Vertical Range, and Marker.

The 0 μ s Position (zero microsecond position) submenu key opens the Select 0 μ s Position list box, which has three options: Left, Center, and Right. Highlight a position with the arrow keys or the rotary knob and then press **Enter**.

The Marker menu displays more submenu keys when Marker is On, and the Delta Marker submenu key is displayed only when the Frequency Response submenu key is active.

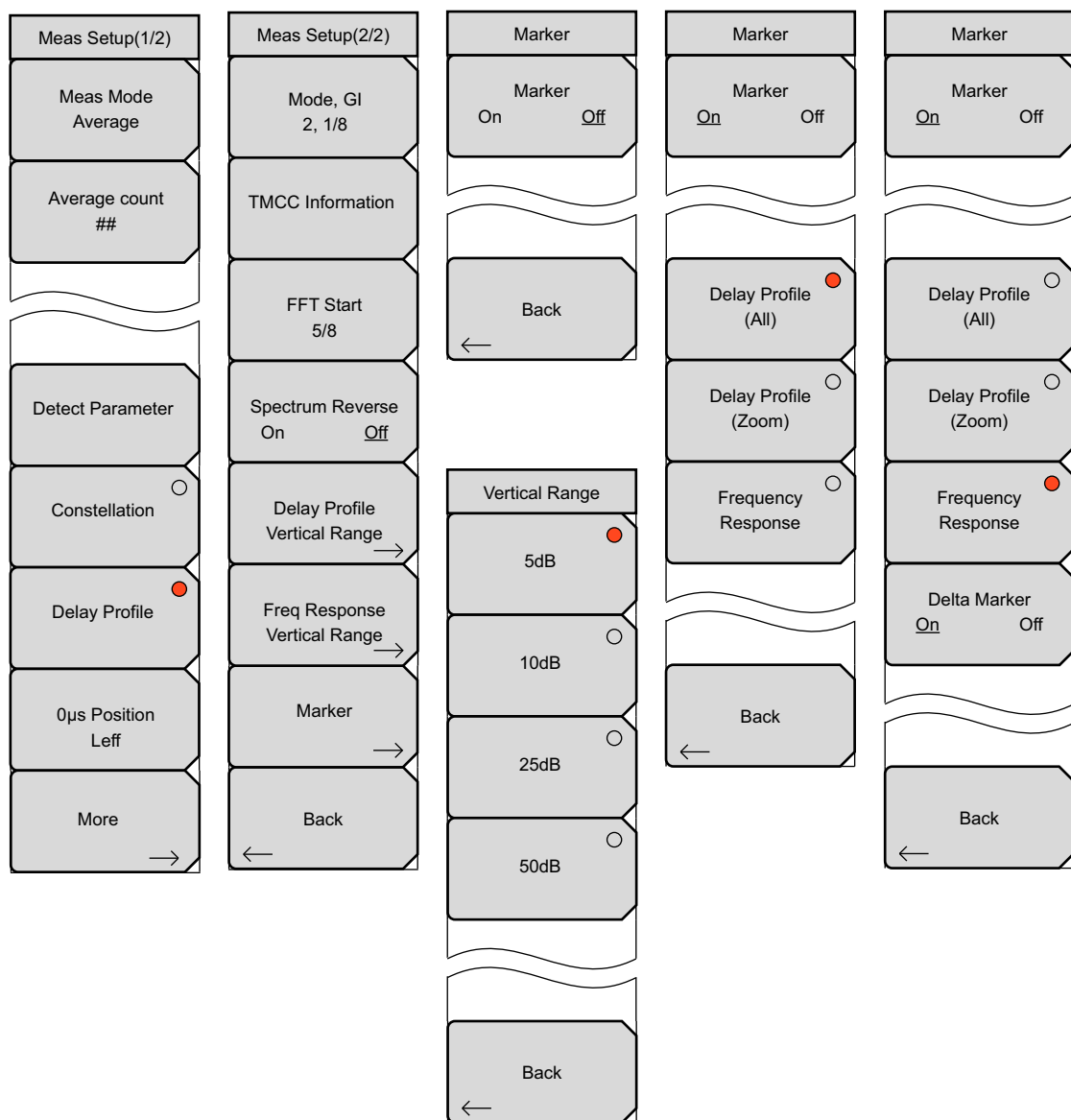


Figure 4-12. Delay Profile Setup and Marker Menus

Measurement Mode Selection for Modulation Analysis

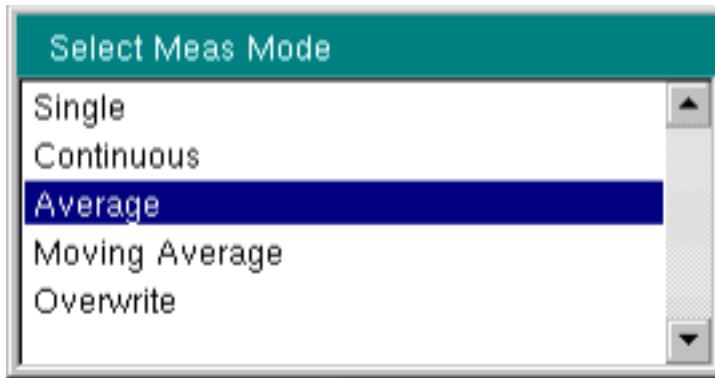


Figure 4-13. Select Measure Mode List Box – Modulation Analysis

In the Custom Modulation Analysis measurement mode, 5 choices are available, as displayed in [Figure 4-13](#).

Single: In this mode, the instrument sets the test for one measurement. Acquires the measurement and displays the results to the screen. This mode is useful for screen capture.

Continuous: In this mode, the instrument sets the test to take measurements continuously. Results are updated on the screen. This mode is helpful for real-time signal analysis.

Average: In this mode, the instrument averages the measurement results for the specified number of measurements set in Average Count. During the measurement, the status bar at the top of the screen displays the current measurement count and average count selection. The screen displays the average of the measurements results after the final count. Refer to the submenu key description for [“Average Count” on page 4-75](#) and [“Average Count” on page 4-77](#).

Moving Average: This mode is useful while aiming the antenna. In this mode, the instrument takes the number of measurements set in Average Count. Then an average result is calculated from those measurements and displayed on the screen. Another measurement is taken, and another average is calculated from the last number of measurements set in Average Count. For an example of Average Count calculation, refer to [“Moving Average” on page 4-75](#).

Overwrite (Constellation Only): In this mode, the instrument displays the next constellation measurement result without deleting the previous constellation data. When Meas Mode is set to Overwrite, only the Meas Mode, Detect Parameter, and More submenu keys are displayed in the Meas Setup (1/2) menu, and the Zoom submenu key is no longer displayed in the Meas Setup (2/2) menu. This mode is useful for monitoring the constellation over a period of time in order to determine the worst case during that time period. This is similar to the max hold function in some other measurement modes.

Making a Measurement:

Configure the following Delay Profile parameters: Delay Profile Vertical Range, Freq Response Vertical Range, and Marker.

1. Press the 0 μ s Position submenu key to open the Select 0 μ s Position list box.
2. Use the **Up/Down** arrow keys or the rotary knob to highlight a position (Left, Center, or Right), then press **Enter**.
3. From the Meas Setup (1/2) menu, press the **More** submenu key to open the Meas Setup (2/2) menu.
4. Press the Delay Profile Vertical Range submenu key to open the Vertical Range menu.
5. Press the desired #_dB units submenu key to set the y-axis of the Delay Profile (All) and Delay Profile (Zoom) graphs. Refer to [Figure 4-14](#) for an example of these graphs.
6. Press **Back** to return to the Meas Setup (2/2) menu
7. Press the Freq Response Vertical Range submenu key to open the Vertical Range menu.
8. Press the desired #_dB units submenu key to set the y-axis of the Frequency Response graph.
9. Press **Back** to return to the Meas Setup (2/2) menu.
10. Press the **Spectrum Reverse** submenu key to toggle the measurement feature On or Off. The active state is underlined.
11. Press **Back** again, to return to the Meas Setup (1/2) menu.
12. Press the **More** submenu key to open the Meas Setup (2/2) menu.
13. Press the **Marker** submenu key to open the Marker menu.
14. Toggle the **Marker** submenu key to On (if necessary) to activate the marker functions.
When **Marker** is toggled to Off, only 2 submenu keys are displayed: **Marker** and **Back**.
When **Marker** is toggled to On, 3 additional submenu keys are available: **Delay Profile (All)**, **Delay Profile (Zoom)**, and **Frequency Response**. The active submenu key displays a red circle.
15. Press the **Delay Profile (All)** submenu key to display a green rectangle range marker in the Delay Profile (All) graph. Use the rotary knob or the arrow keys to select a range.
The range is divided within the Delay Profile (All) graph. The blue range shows signals that are delayed less than 0 μ s if the largest signal (not necessarily the least delayed) is set at 0 μ s. The yellow area shows delayed signals that are within the Guard Interval. The magenta area shows signals that are delayed beyond the Guard Interval (which are potentially problematic). While the Delay Profile (All) graph shows a wide range, the narrower range (that is defined by the green rectangle range marker) is displayed in the Delay Profile (Zoom) graph. The Delay Profile (Zoom) graph uses the same colors as the Delay Profile (All) graph.
16. Press the **Delay Profile (Zoom)** submenu key to display a green diamond marker in the Delay Profile (Zoom) graph. The delay (in microseconds), the distance (in meters), and the dB value at the marker (relative to the 0 μ s position) are displayed in the graph.
17. Press the **Frequency Response** submenu key to display a green diamond marker on the frequency response graph within the channel bandwidth. When the

Frequency Response submenu key is active, the Delta Marker submenu key is displayed in the Marker menu.

18. Press the Delta Marker submenu key to toggle the Delta Marker On (if necessary). When the Delta Marker is On, it is a green diamond, and the reference marker is a green rectangle. Use the Delta Marker to display the difference in level, distance, and frequency between two points. These three values are displayed in the frequency response graph.
19. Press the **Execute Measure** main menu key to begin testing.
20. To save the test results, press the **Save Files** main menu key. Refer to the section, [“Saving the Measurement Results” on page 4-52](#) for more information regarding saving files.

The Meaning of Color in the Delay Profile Graph

The blue range (as shown in [Figure 4-14](#)) shows signals that are delayed less than 0 μs if the largest signal (not necessarily the least delayed) is set at 0 μs . The yellow area shows delayed signals that are within the Guard Interval. The magenta area shows signals that are delayed beyond the Guard Interval (which are potentially problematic).

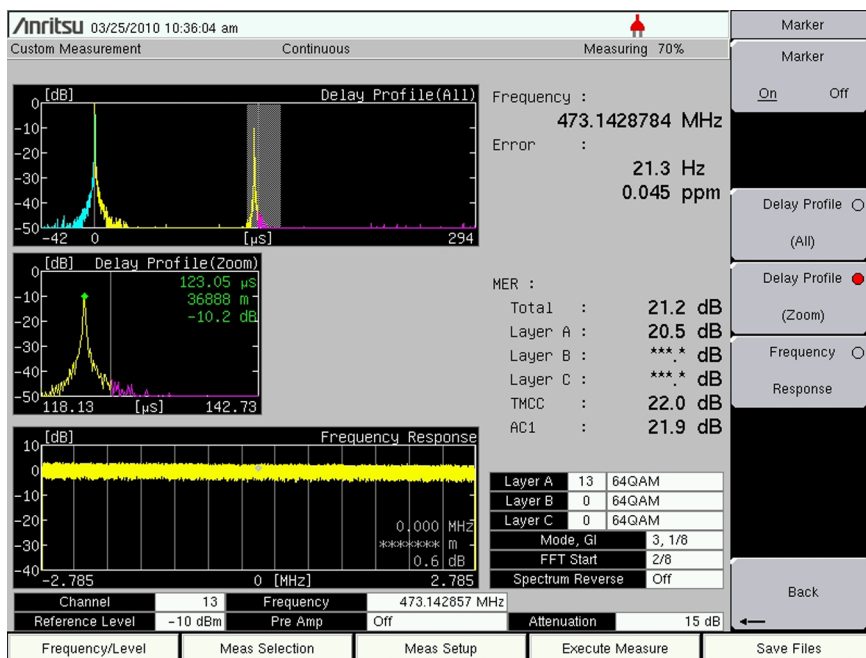


Figure 4-14. Modulation Analysis – Delay Profile

The sample image in [Figure 4-14](#) may differ from any display on your instrument.

The sample image in [Figure 4-15](#) may differ from any display on your instrument.

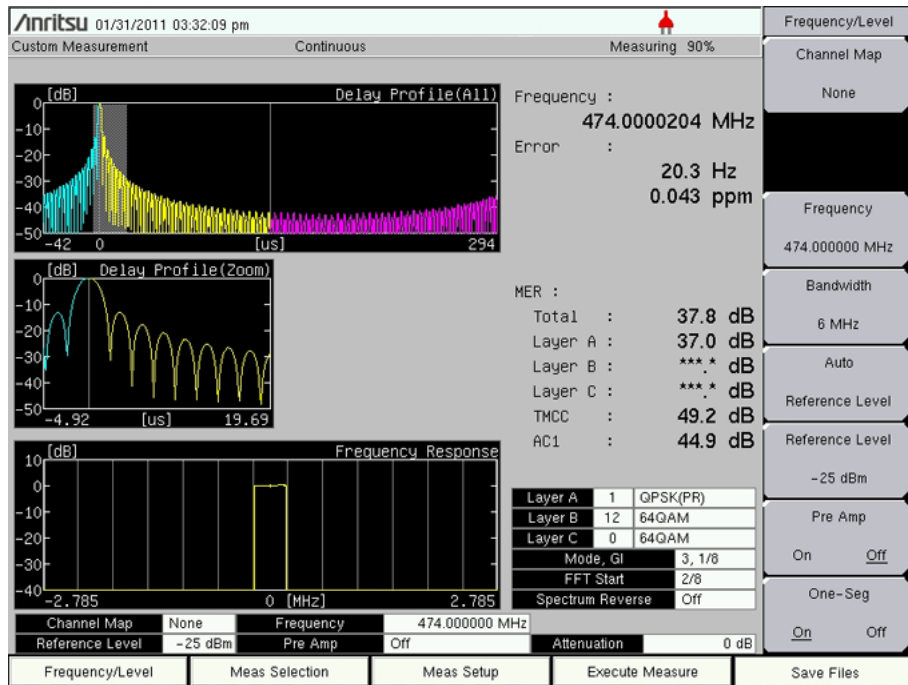


Figure 4-15. Modulation Analysis of Delay Profile, One-Segment

Note the existing settings in [Figure 4-15](#): Channel Map is set to None, Bandwidth is set to 6 MHz, the Pre Amp is On, and One-Seg is set to On. At the top-left corner of the measurement display, “Custom Measurement” indicates that Custom is the measurement selection, as opposed to Batch or Easy.

Additional settings were achieved by pressing **Meas Selection** and then Modulation Analysis. Also, by pressing **Meas Setup** and then Delay Profile.

The delay profile and frequency response graphs are displaying the measurement results for a single channel (one segment). Refer also to the TMCC Information Editor dialog box, as shown in [Figure 4-9 on page 4-24](#).

4-13 Spectrum Mask, Custom

Test Selection:

1. Press the **Meas Selection** main menu key to open the Meas Selection(1/2) menu.
2. Press the Spectrum Mask submenu key.
3. Press the **Frequency/Level** main menu key and then press the Channel Map submenu key to select a Channel Map (UHF, IF, None, or UHF (Brazil)).
4. If you selected a Channel Map of UHF or UHF (Brazil), then press the Channel submenu key to open the Channel Editor dialog box and select a channel number.

Test Setup:

5. Press the **Meas Setup** main menu key to open the Meas Setup menu and configure the available parameters.

Three submenu keys are always displayed: Mask Type, Floor reduction, and Marker.

Four additional submenu keys are displayed for Channel Map

UHF (Brazil): Filter Selection, Filter Data, Corrected Data, and UnCorrected Data.

6. Press the Mask Type submenu key to open the Select Mask Type list box.
7. Use the **Up/Down** arrow keys or the rotary knob to highlight a mask type, then press **Enter**.

The mask types that are available depend upon the Channel Map that was selected in the Frequency/Level menu. To select a mask type, use the **Up/Down** or **Left/Right** arrow keys or use the rotary knob to highlight a list entry, then press **Enter**. The Type B Spectrum Mask is illustrated in [Figure 4-20 on page 4-41](#). The mask type that is selected is displayed in the parameter area of the screen under the Mask Type and Antenna Power.

Masks For Channel Map of UHF, IF, or None:

Type A

Type B ($P > 2.50W$)

Type B ($0.25W < P \leq 2.50W$)

Type B ($P = 0.25W$)

Type B ($0.025W < P < 0.25W$)

Type B ($P \leq 0.025W$)

Masks For Channel Map of UHF (Brazil):

Type Brazil(Critical)

Type Brazil(Subcritical)

Type Brazil(Noncritical)

These three mask types are shown in [Figure 4-16 on page 4-35](#), [Figure 4-17 on page 4-36](#), and [Figure 4-18 on page 4-37](#).

Go next to [Step 8 on page 4-38](#) through [Step 11](#) for UHF (Brazil) Channel Map, then skip to [Step 13 on page 4-41](#). For all others, go directly to [Step 12 on page 4-40](#).

Critical Mask Type, Brazil(Critical)

For UHF (Brazil) Channel Map

The true color of the mask on the instrument display is blue on a black background. To enhance the mask for documentation purposes only, it was changed to yellow in [Figure 4-16](#). In the printed manual, the screen has been changed for better contrast so that the mask line and the data line appear in black against the white background of the screen. Any similar display on your instrument may differ from this example.

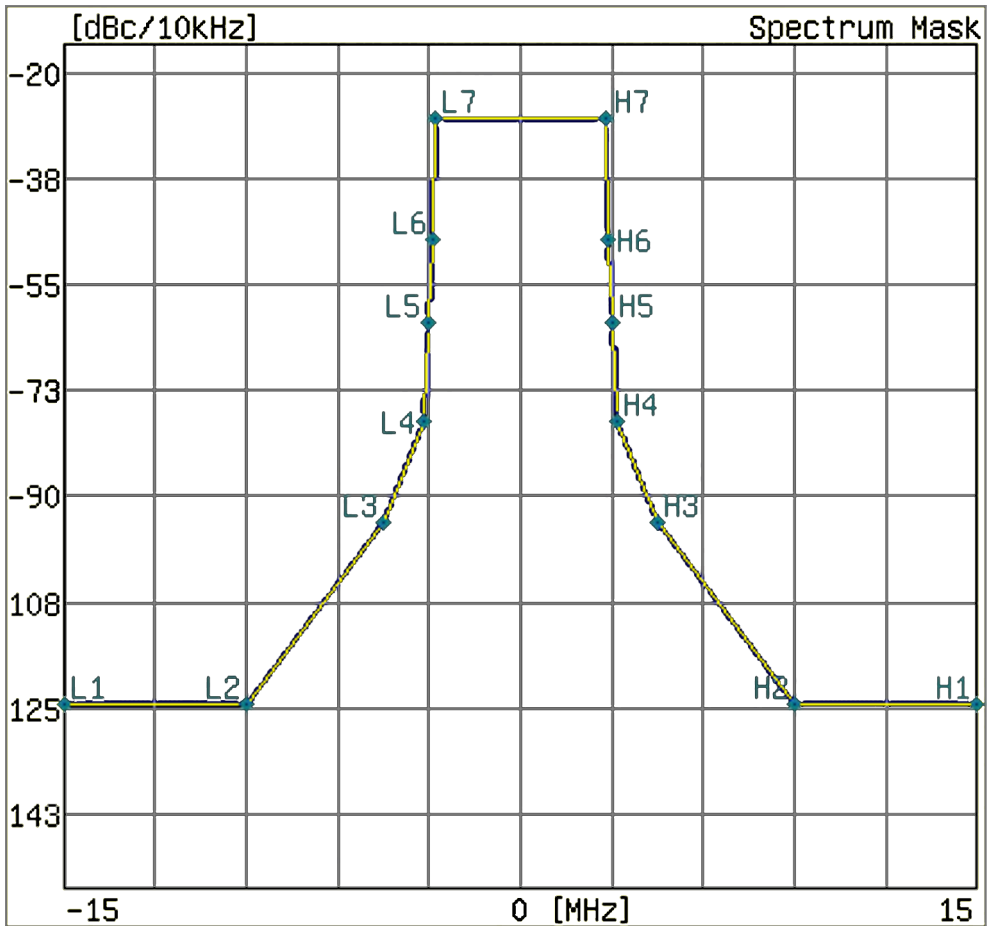


Figure 4-16. Critical Mask for UHF (Brazil) Channel Map

Subcritical Mask Type, Brazil(Subcritical)

For UHF (Brazil) Channel Map

The true color of the mask on the instrument display is blue on a black background. To enhance the mask for documentation purposes only, it was changed to yellow in [Figure 4-17](#). In the printed manual, the screen has been changed for better contrast so that the mask line and the data line appear in black against the white background of the screen. Any similar display on your instrument may differ from this example.

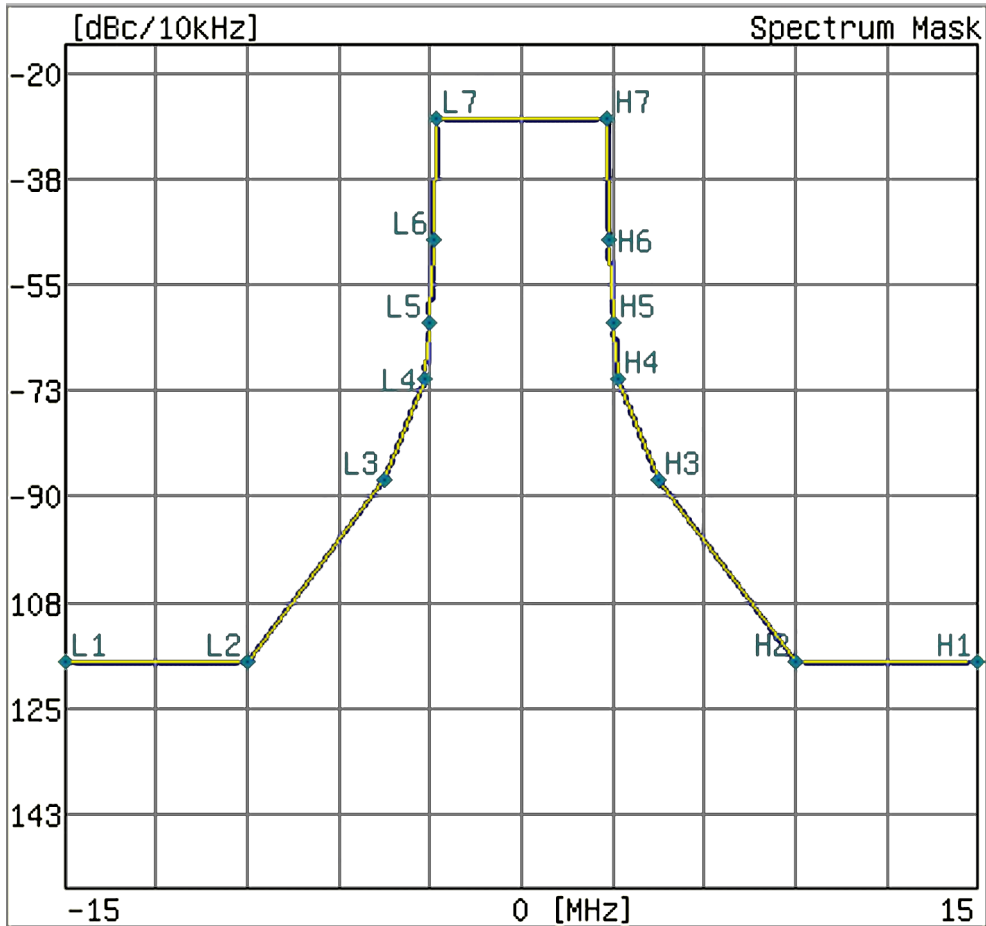


Figure 4-17. Subcritical Mask for UHF (Brazil) Channel Map

Noncritical Mask Type, Brazil(Noncritical)

For UHF (Brazil) Channel Map

The true color of the mask on the instrument display is blue on a black background. To enhance the mask for documentation purposes only, it was changed to yellow in [Figure 4-18](#). In the printed manual, the screen has been changed for better contrast so that the mask line and the data line appear in black against the white background of the screen. Any similar display on your instrument may differ from this example.

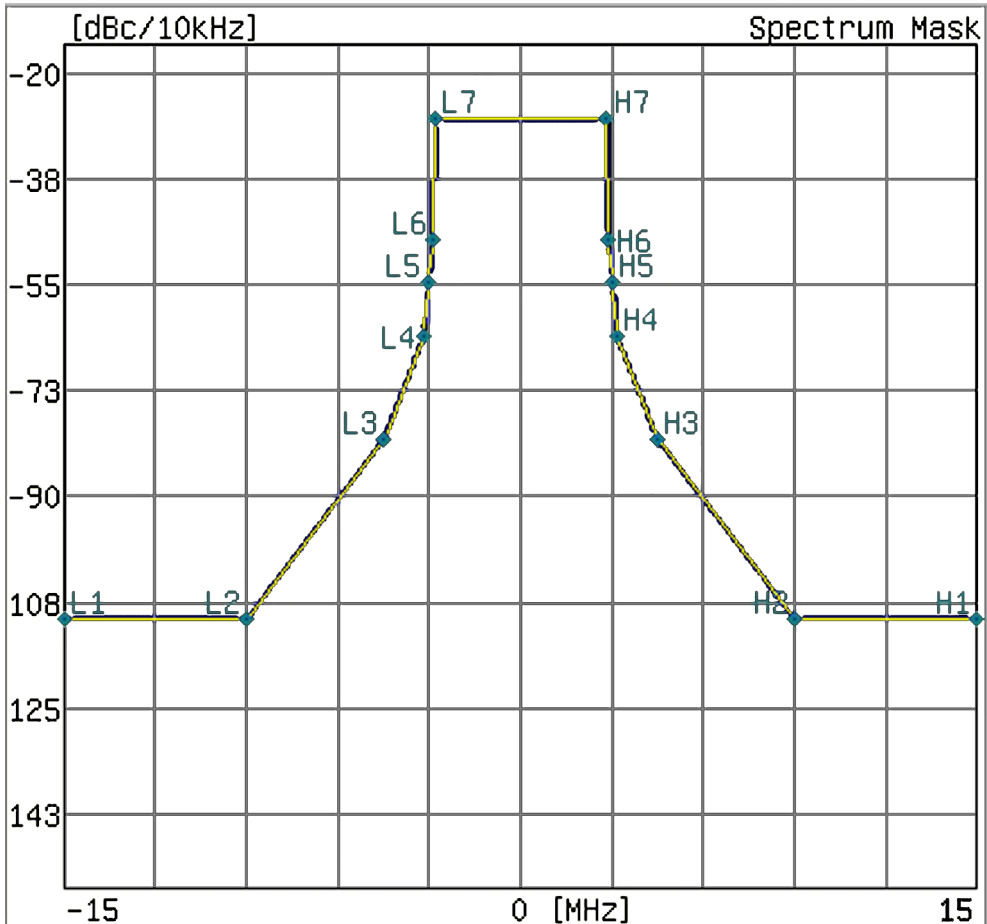


Figure 4-18. Noncritical Mask for UHF (Brazil) Channel Map

UHF (Brazil) Channel Map Test Setup:

8. Press the Filter Selection submenu key to open the Select Filter list box. Use the Default filter or select one of the three user-specified filters. The default selection is for typical transmitter output filter characteristics. Refer to [Table 4-14 on page 4-38](#) for the default filter parameters.

Other transmitter output filter characteristics can be created by using Master Software Tools. Refer to the Master Software Tools User Guide. You can save your own filter specifications with meaningful titles to replace those that are labeled User1, User2, and User3 in the Select Filter list box.

Table 4-14. Default Filter Characteristics Normalized to -27.4 dB

Offset (MHz)	Attenuation (dB)
-15.00	52.00
-9.00	52.00
-4.50	22.00
-3.15	24.57
-3.00	11.00
-2.86	0.00
-2.79	0.00
0.00	0.00
2.79	0.00
2.86	0.00
3.00	11.00
3.15	24.57
4.50	22.00
9.00	52.00
15.00	52.00

- Press the **Filter Data** submenu key to turn this feature On or Off. When On, the filter characteristics (normalized to -27.4 dB) are displayed in green. This green display is not part of the measurement.

Figure 4-19 shows two measurement lines. The line through the points labeled L1 to L7 and H7 to H1 is displayed in blue in the graph on the instrument screen and represents the applicable mask. The line that begins at approximately -80 dBc/10 kHz and passes through the points labeled L6, L7, H7, and H6 is displayed in green in the graph on the instrument screen and represents the filter characteristics. In the printed manual, the screen has been changed for better contrast so that the blue mask line and the green filter data line appear in black against the white background of the screen. The instrument displays a black background, which has been changed to white for documentation purposes. Any similar display on your instrument may differ from this example.

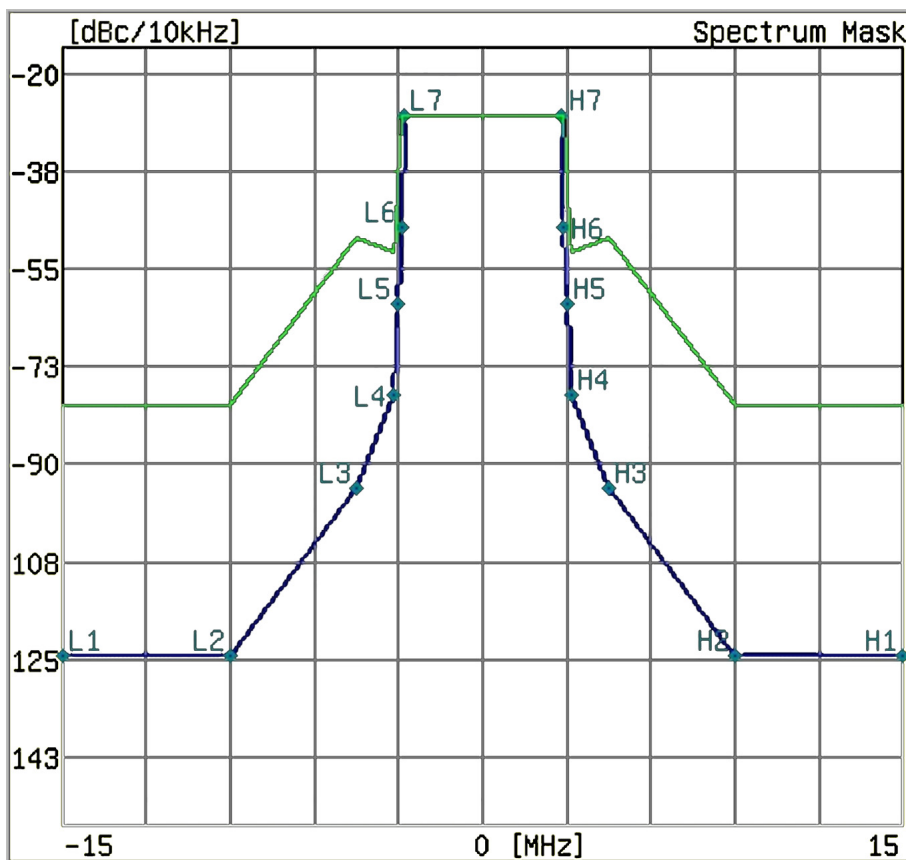


Figure 4-19. Default Filter Data (Green Line) Normalized to -27.4 dB

- Press the **Corrected Data** submenu key to turn this feature On or Off. When On, the Corrected Data is displayed in yellow. This yellow measurement data is the measurement data after being corrected with the filter characteristics (the filter must first be applied).

11. Press the **UnCorrected Data** submenu key to turn this feature **On** or **Off**. When **On**, the **UnCorrected Data** is displayed in gray. This represents the uncorrected data before the filter correction has been applied. Skip to [Step 13 on page 4-41](#).

Other Channel Maps Test Setup:

12. If mask type is **Type B** ($0.25W < P \leq 2.50W$) or **Type B** ($0.025W < P < 0.25W$), then set up the antenna power by pressing the **Antenna Power** submenu key, which is displayed only for these two mask types.

- a. Press the **Antenna Power** submenu key to open the **Antenna Power Editor** dialog box and to display the **Units** menu, which has two submenu keys: **W** and **mW**. The range and increments of change are displayed in the dialog box.

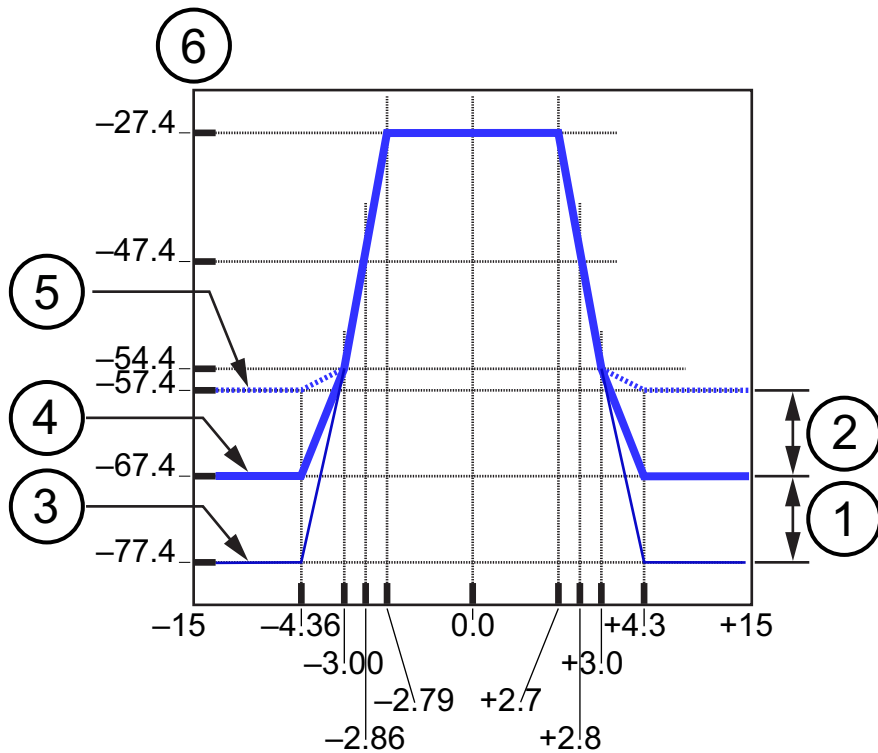
You may use the numeric keypad to set the power level, then press a **Units** submenu key for watts or milliwatts. Pressing the **Enter** key is the same as pressing the **W** submenu key.

You may also use the **Up/Down** arrow keys and the rotary knob to set the power level, and then press either the **W** submenu key or the **Enter** key. The **Up/Down** arrow keys change the power level in increments that are 10 times the incremental steps that are shown in the dialog box, and the rotary knob changes the power level in the displayed increments. The value that is displayed in the dialog box is within the indicated range, which is expressed in watts, so pressing the **mW** submenu key produces an “Out of range.” message.

- b. If mask type is **Type B** ($0.25W < P \leq 2.50W$), then set the antenna power within the range 0.26 W to 2.50 W. If mask type is **Type B** ($0.025W < P < 0.25W$), then set the antenna power within the range 0.026 W to 0.249 W. When changing the antenna power, the out-of-band floor part of the mask standard line is changed as shown in [Figure 4-20](#), items 1 and 2.

Type B Spectrum Mask:

The masks (labeled 3, 4, and 5 in Figure 4-20) are shown in blue in the PDF file (black in the printed manual). The x-axis is in MHz, and the y-axis is in dBc/10 kHz.



1	Modified range when using mask standard Type B ($0.25 \text{ W} < P \leq 2.50 \text{ W}$)
2	Modified range when using mask standard Type B ($0.025 \text{ W} < P < 0.25 \text{ W}$)
3	Line when using mask standard Type B ($P > 2.50 \text{ W}$)
4	Line when using mask standard Type B ($P = 0.25 \text{ W}$)
5	Line when using mask standard Type B ($P \leq 0.025 \text{ W}$)
6	Attenuation in units of dBc/10 kHz

Figure 4-20. Type B Spectrum Mask

13. Press the Floor Reduction submenu key to turn On or Off the floor reduction adjustment. Pressing this submenu key (to On or Off) triggers a measurement.

The Floor Reduction function lowers the influence of the floor noise (of the instrument) on the spectrum mask measurement. When Off, the spectrum analyzer measurement is displayed directly, as the signal spectrum (this is the normal measurement method). When On, the spectrum analyzer measurement is adjusted by subtracting the noise floor of the instrument from the signal spectrum.

14. Press the Marker submenu key to turn On or Off the marker feature. A green diamond marker is displayed on the measured signal. The values that are displayed in the upper-right corner of the graph are the relative frequency of the marker position (based on the graph center) and the relative level of the marker position (based on the 0 dB position of the graph).

15. Press the **Execute Measure** main menu key to begin testing.

The measurement that is displayed in [Figure 4-21](#) may differ from any display on your instrument.

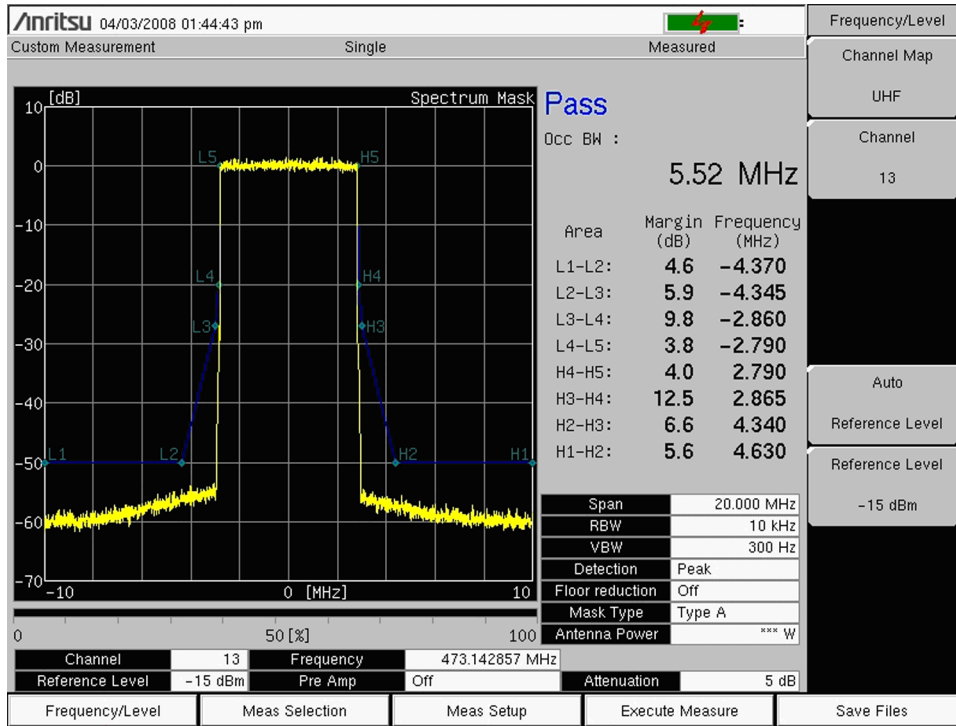
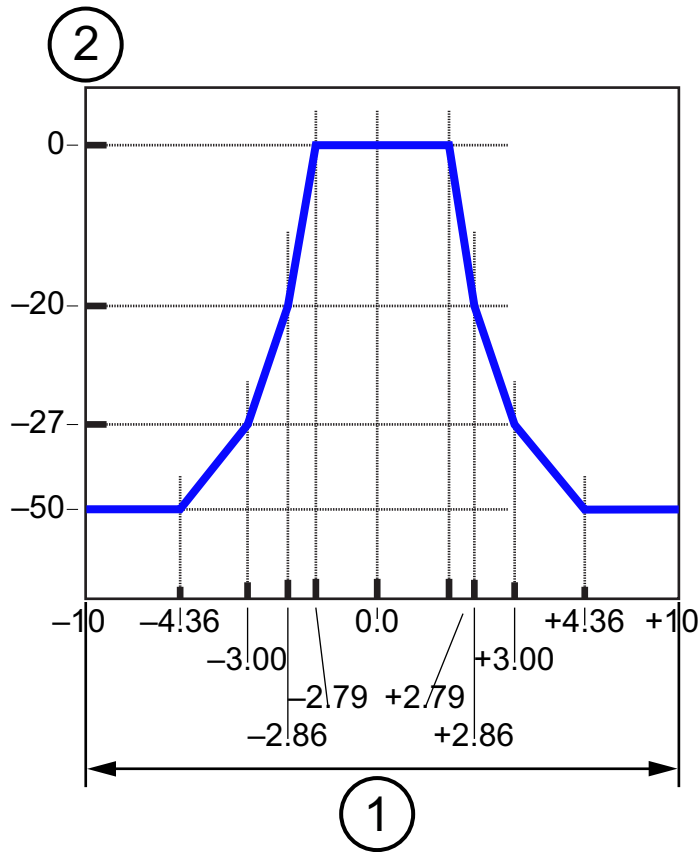


Figure 4-21. Transmitter Spectrum Mask

16. Save measurements to file by pressing the **Save Files** main menu key. Refer to the section, [“Saving the Measurement Results”](#) on page 4-52 for more information regarding saving files.

Type A Spectrum Mask:

The Type A Spectrum Mask that is shown in [Figure 4-22](#) is displayed in blue in the PDF file (black in the printed manual). The x-axis is in MHz, and the y-axis is in dB.



1	Difference from Center Frequency of a Channel (MHz)
2	Relative Level (dB)

Figure 4-22. Type A Spectrum Mask

4-14 Phase Noise, Custom

Test Selection:

1. Press the **Meas Selection** main menu key.
2. Press the Phase Noise submenu key.

Test Setup:

3. Press the **Meas Setup** main menu key to open the Meas Setup menu.
4. Press the **Meas Mode** submenu key to open the Select Meas Mode list box. Select from: **Single**, **Continuous**, and **Average**. Scroll through to the desired measure mode using the **Up/Down** arrow keys or the rotary knob to highlight the measure mode and then press **Enter**.

If **Average** is selected, then set up **Average Count**. Otherwise, continue to configure Marker at [Step 5](#).

- a. Press the **Average Count** submenu key to open the Average Count Editor list box.
 - b. Scroll through to the desired number count by using the **Up/Down** arrow keys or the rotary knob. The count may be entered by using the numeric keypad. Press **Enter** to set the value.
5. Press the **Marker** submenu key to select either **On** or **Off**.

If **On** is selected, then the marker (a green diamond) is displayed on the graph, and the **Integration** submenu key is displayed in the menu. Use the arrow keys or the rotary knob to move the marker. Three measurement point values at the marker location are displayed in the graph. These three values and their respective units are frequency offset (Hz), Phase Noise (dBc/Hz), and signal-to-marker ratio (dBc).

6. Press the **Integration** submenu key to add the integration marker on the graph. The range between the standard marker and the integration marker is shown in white between 2 vertical green lines on the graph. The differences in point measurements from the standard marker to the integration marker are displayed in green at the top right corner of the Phase Noise graph as a frequency range and a dBc value. The sample image in [Figure 4-23](#) may differ from any display on your instrument.

- Press the **Execute Measure** main menu key to begin testing.

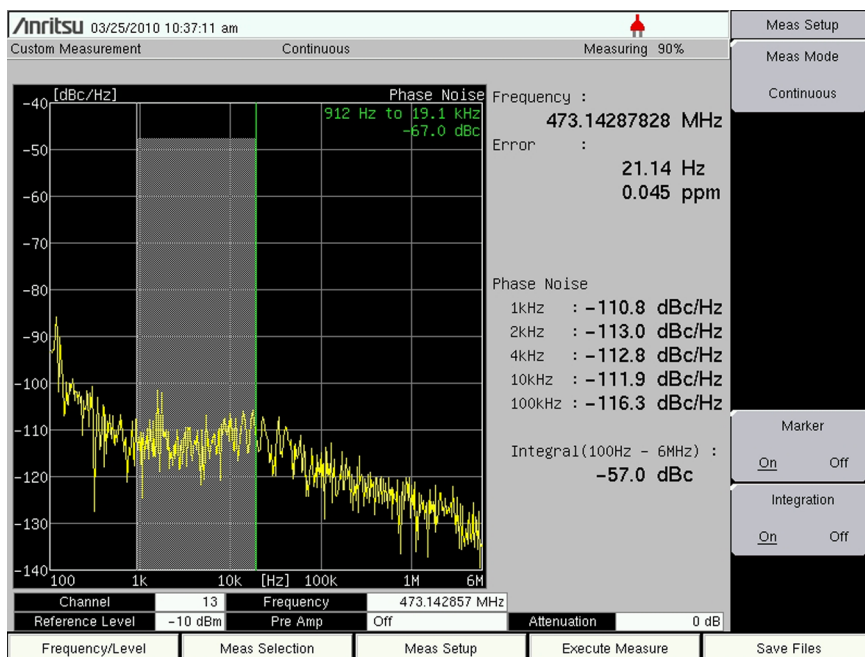


Figure 4-23. Transmitter Phase Noise Measurement with Integration Marker On

- Save measurements to file by pressing the **Save Files** main menu key. Refer to the section, [“Saving the Measurement Results”](#) on page 4-52 for more information regarding saving files.

4-15 Spurious Emissions, Custom

Test Selection:

1. Press the **Meas Selection** main menu key.
2. Press the Spurious Emissions submenu key.

When entering the Spurious Emissions measurement mode, you may receive the following message:

```
<< Information >>  
Set HPF to RF terminal.  
Press ENTER to continue.
```

This message is advising you to insert a High Pass Filter (HPF) at the RF In port of your instrument. The purpose is to filter out the transmitted signal so that spurious emissions can be detected with greater sensitivity.

Test Setup:

3. Press the **Meas Setup** main menu key to open the Meas Setup menu.

Configure HPF Loss:

4. Press the HPF Loss submenu key to open the HPF Loss dialog box. Use the **Up/Down** arrow keys or the rotary knob to scroll to the desired value and then press **Enter**. You may also use the numeric keypad to enter a value and then press either the **dB** submenu key or the **Enter** key. The HPF Loss step increments and range are listed in the dialog box.
5. Press the **Execute Measure** main menu key to begin testing.

- Save measurements to file by pressing the **Save Files** main menu key. Refer to the section, [“Saving the Measurement Results”](#) on page 4-52 for more information regarding saving files.

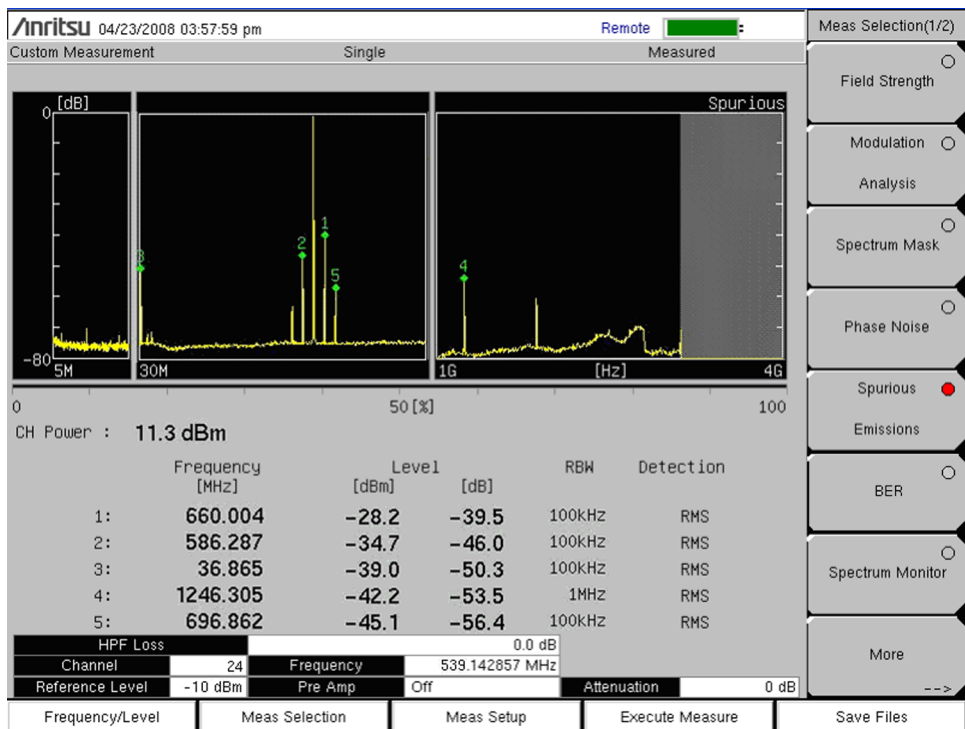


Figure 4-24. Spurious Emissions Measurement

4-16 BER Measurements Setup, Custom (Option 79)

Measurement of BER is a useful tool for evaluating the quality of a broadcast signal. This option requires that additional hardware be installed in the instrument in order to perform Bit Error Rate (BER) measurements on ISDB-T broadcast signals. Bit Error Rate (BER), Packet Error Rate (PER), TMCC, and MPEG TS Bit Rate can be measured simultaneously.

ASI Out Connector

The digital signal output, 50 ohm Type-N female connector (shown in [Figure 1-1 on page 1-3](#)) is present only when both ISDB-T (Option 30 and ISDB-T BER (Option 79) are installed on your instrument.

The ASI function produces MPEG TS data output during a BER measurement. This output can be connected to MPEG TS analysis equipment to monitor video errors, or it can be connected via an appropriate ASI-to-USB demultiplexing and decoding accessory for channel identification and monitoring purposes.

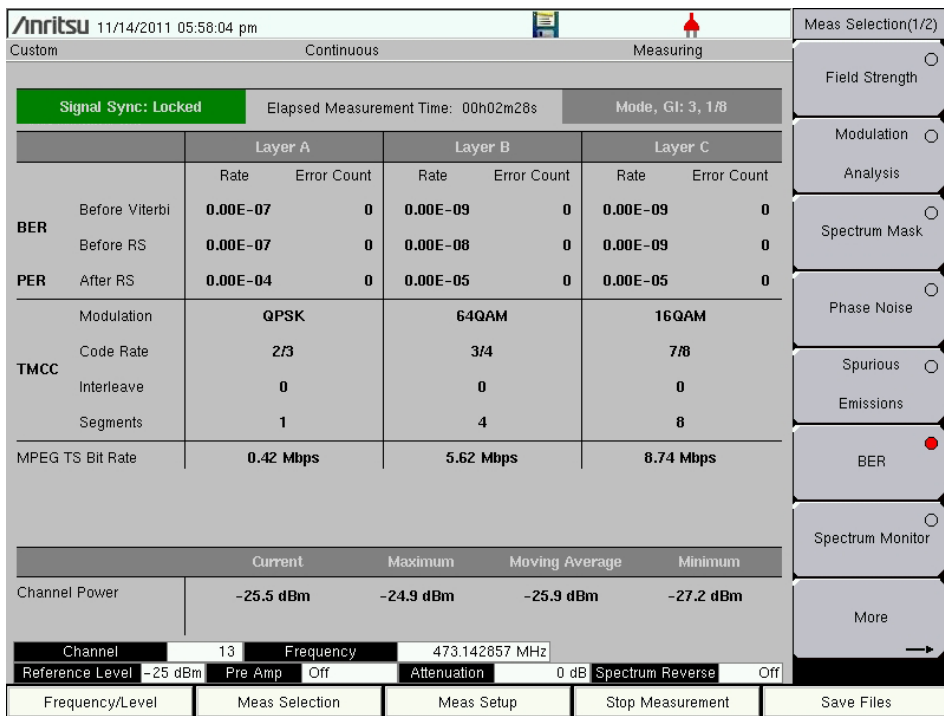


Figure 4-25. BER Measurement Selection

Test Selection:

1. Press the **Meas Selection** main menu key.
2. Press the BER submenu key.

Test Setup:

1. Press the **Meas Setup** main menu key to open the Meas Setup menu.
2. Press the Spectrum Reverse submenu key to select either On or Off. The active state is underlined.
3. Press the **Start Measurement** main menu key to begin testing. When testing is complete, press the **Stop Measurement** main menu key.

4-17 Spectrum Monitor, Custom

Test Selection:

1. Press the **Meas Selection** main menu key.
2. Press the Spectrum Monitor submenu key.

The **Span** setting selects the number of channels to display on the measurement screen (graph). The channel (when 1CH is selected in **Span**) is the channel that was selected in the **Frequency/Level** menu (refer to section “[Frequency and Reference Level Configurations](#)” on page 4-6 and to [Step 2](#) and substep [Step b](#)). You can use that menu to change the channel number. When multiple channels are displayed (by using the **Span** setting), the channel number that is selected in the **Frequency/Level** menu is displayed as the center channel.

The channel number, the channel frequency, and the power level are displayed in green in the graph. The frequency and power level at the blue diamond marker are displayed in blue in the graph. The blue diamond marker always denotes the peak level within the green zone.

Test Setup:

1. Press the **Meas Setup** main menu key to open the Meas Setup menu to configure the following parameters: **Measure Mode**, **Span**, and **Zone Position**.
2. Press the **Meas Mode** submenu key to open the Select Meas Mode list box.
Use the **Up/Down** arrow keys or the rotary knob to highlight the desired measurement mode and then press **Enter**. Choose from: **Single** and **Continuous**.
3. Press the **Span** submenu key to open the Select Span list box.
Use the **Up/Down** arrow keys or the rotary knob to highlight the desired number of channels to span, and then press **Enter**. Refer to [Table 4-15](#) for the RBW, VBW, and Detection parameters for each Span setting. The values that are shown in this table are set internally and are not displayed on the instrument screen.

Table 4-15. Span Options with Associated RBW, VBW, and Detection Parameters

Span	RBW	VBW	Detection
1 CH	10 kHz	3 kHz	RMS
3 CH	10 kHz	10 kHz	RMS
5 CH	10 kHz	30 kHz	RMS
11 CH	10 kHz	30 kHz	RMS
31 CH	10 kHz	100 kHz	RMS
51 CH	1 MHz	300 kHz	RMS

4. Press the **Zone Position to Center** submenu key to set the current zone marker (green rectangle) to the center of the screen.
5. Press the **Execute Measure** main menu key to begin testing.

- Save measurements to file by pressing the **Save Files** main menu key. Refer to the section, [“Saving the Measurement Results” on page 4-52](#) for more information regarding saving files.

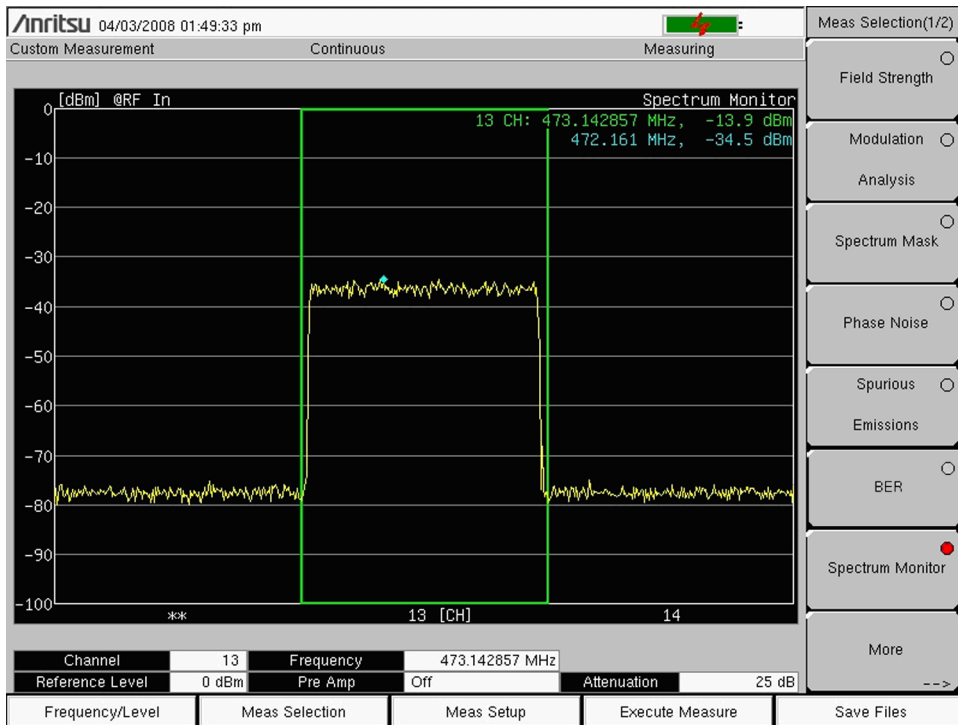


Figure 4-26. Spectrum Monitor Display

The sample image in [Figure 4-27](#) may differ from any display on your instrument.

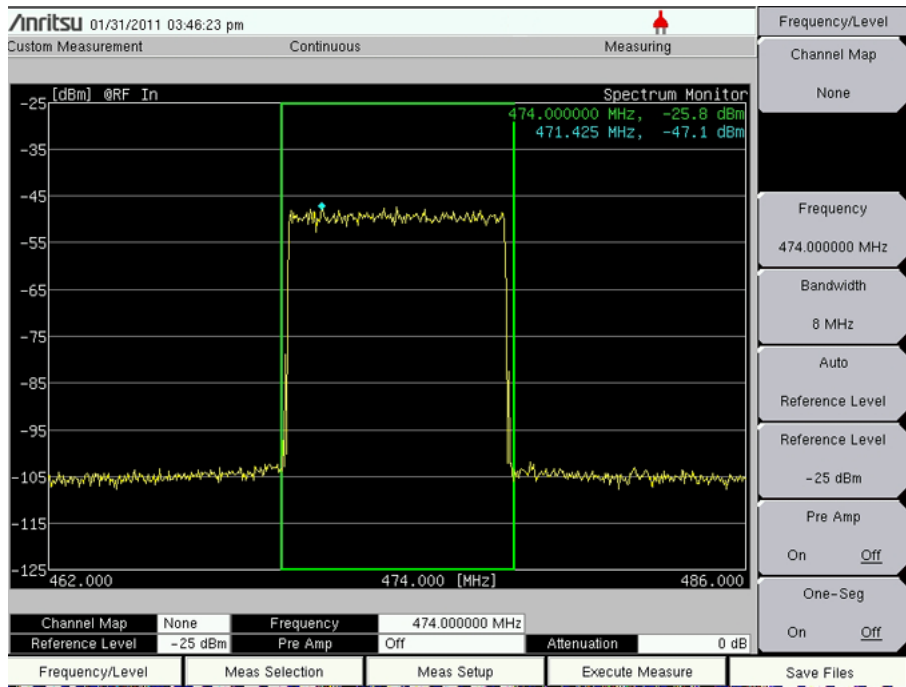


Figure 4-27. Spectrum Monitor with 8 MHz Bandwidth Selected

The measurement in [Figure 4-27](#) is an example using a Bandwidth setting of 8 MHz.

4-18 Saving the Measurement Results

Included in the instrument is a feature to save the current displayed measurement. Saved formats are JPEG and CSV. Batch measurement mode files have `_GRP` added to the end of the filename. Files are stored to the internal memory of the instrument. Files can be saved automatically or manually. Refer to [“Saving a File Automatically”](#).

Filenames are based on the type, date, and time of measurement.

Figure 4-28. Measurement Filename Convention

Measurement Item	Filename Prefix	Example (19:30:25, January 2, 2008)
Field Strength	PWR	PWR20080102_193025.jpg
Modulation Analysis/Constellation	CON	CON20080102_193025.jpg
Modulation Analysis/Delay Profile	PRO	PRO20080102_193025.jpg
Spectrum Mask	MSK	MSK20080102_193025.jpg
Phase Noise	PHN	PHN20080102_193025.jpg
Spurious Emissions	SPR	SPR20080102_193025.jpg
BER	BER	BER20080102_193025.jpg
Spectrum Monitor	SPM	SPM20080102_193025.jpg
Batch	SPM	SPM20080102_193025_GRP.csv

Manually saving measurements to file includes a few more steps than saving a file automatically. Refer to [“Saving a File Manually”](#). The advantages of saving a file manually are that you have the following choices:

- Choosing to save the file setup
- Saving the measurement to file
- Saving the file in JPEG format
- The ability to name the file

Saving a File Automatically

Press the **Save Files** main menu key.

When the saving process is complete, an information window, similar to [Figure 4-29](#), is briefly displayed.

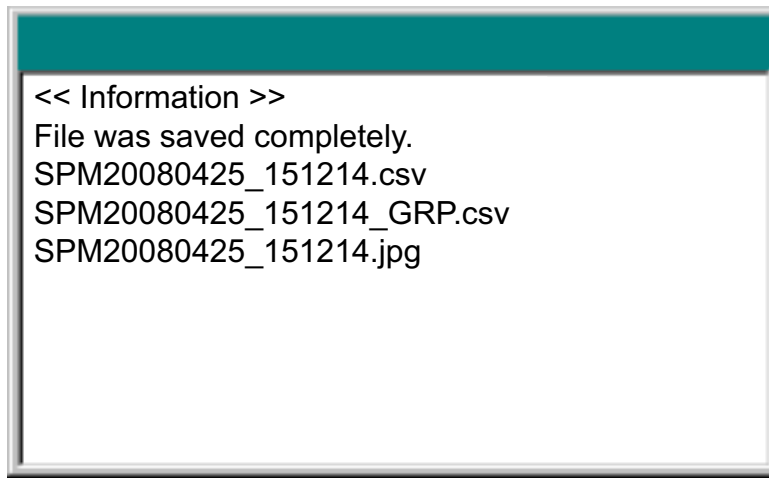


Figure 4-29. Successful File Saving Message

Saving a File Manually

1. On the number keypad, press the blue **Shift** key followed by the **File** (7) key to open the File menu.
2. Press one of the three “Save” submenu keys.

Save Measurement As “Filename”

Press the **Save Measurement As** submenu key to quickly save a measurement with the filename that is displayed on the submenu key. The number that is appended to the filename is automatically incremented with each save action, and the name is then displayed on the face of the submenu key. The save location is determined by the most recent setting that has been used in the **Save Measurement** dialog box or the **Save** dialog box. The filename can be changed by using the **Save Measurement** dialog box or the **Save** dialog box.

Save Measurement

- a. Press the **Save Measurement** submenu key to save a measurement. The **Save** dialog box and the **Save** menu are both displayed. The **Save** dialog box is initially set with “Measurement” as the Filetype.

An extension is automatically applied based upon the current measurement mode.

- b. Use this dialog box to enter a filename that is subsequently used by the **Save Measurement As** submenu key.
- c. Follow the instructions in the **Save** dialog box for text entry and saving.
- d. The **Save** menu includes submenu keys to change the save location and the file type.

Save

- a. Press the **Save** submenu key to open the **Save** dialog box and the **Save** menu. This is the same dialog box as described for the **Save Measurement** submenu key, but with Filetype set to the file type that was last saved with this dialog box.
- b. Use this dialog box to enter a filename that is subsequently used by the **Save Measurement As** submenu key.
- c. Follow the instructions for text entry and saving.

4-19 ISDB-T Menus and Measurements for Custom and Easy

The remainder of this chapter provides descriptions of all available submenu keys in the Easy Measurement mode and the Custom Measurement mode. Individual menu descriptions include the key sequence that causes the menu to be displayed.

In some Anritsu manuals, **main menu keys** may also be called **hard keys**, and submenu keys may also be called **soft keys**.

All possible submenu keys are displayed in menu images, although some keys are displayed only under unique setup conditions. The individual menu descriptions contain explanations of such keys.

Frequency/Level Menu Group — Custom

Frequency/Level menus vary depending upon the Channel Map selection and the Custom or Easy setting.

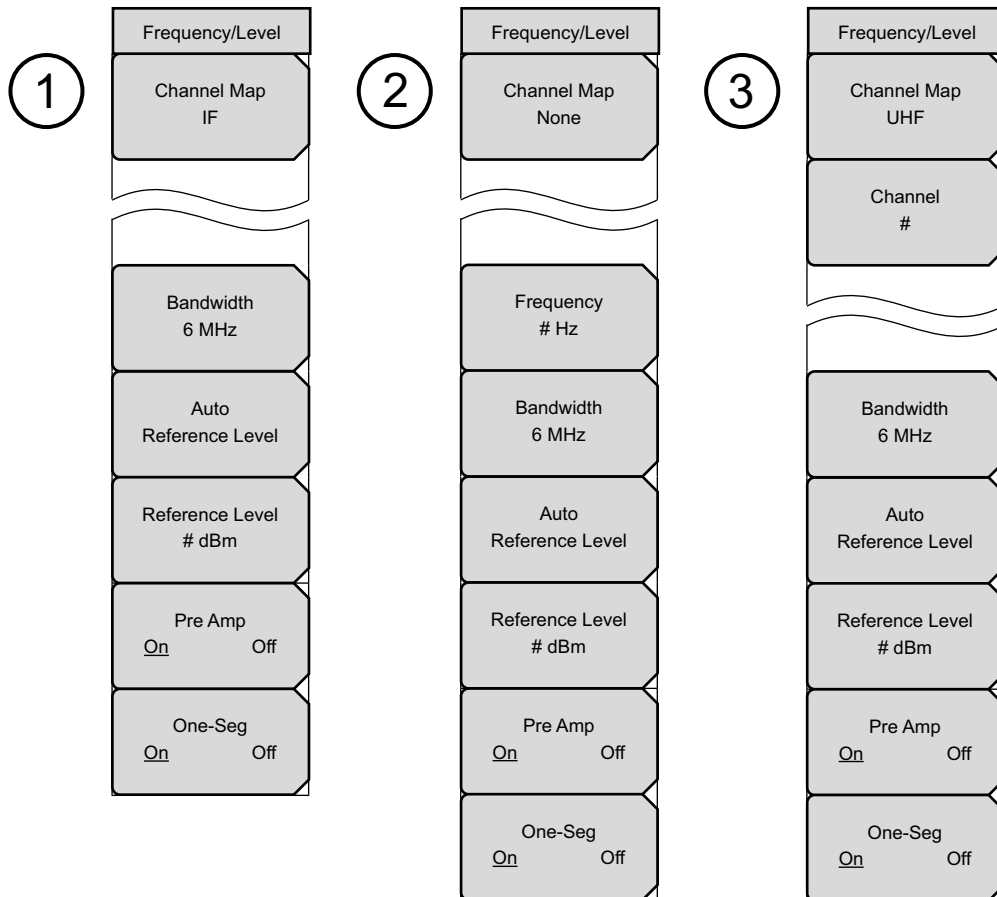


Figure 4-30. Frequency/Level Menus for Custom

1	IF Channel Map, Custom Setup
2	No Channel Map (set to None), Custom Setup
3	UHF or UHF (Brazil) Channel Map, Custom Setup

Frequency/Level Menu Group — Easy

Frequency/Level menus vary depending upon the Channel Map selection and the Custom or Easy setting.

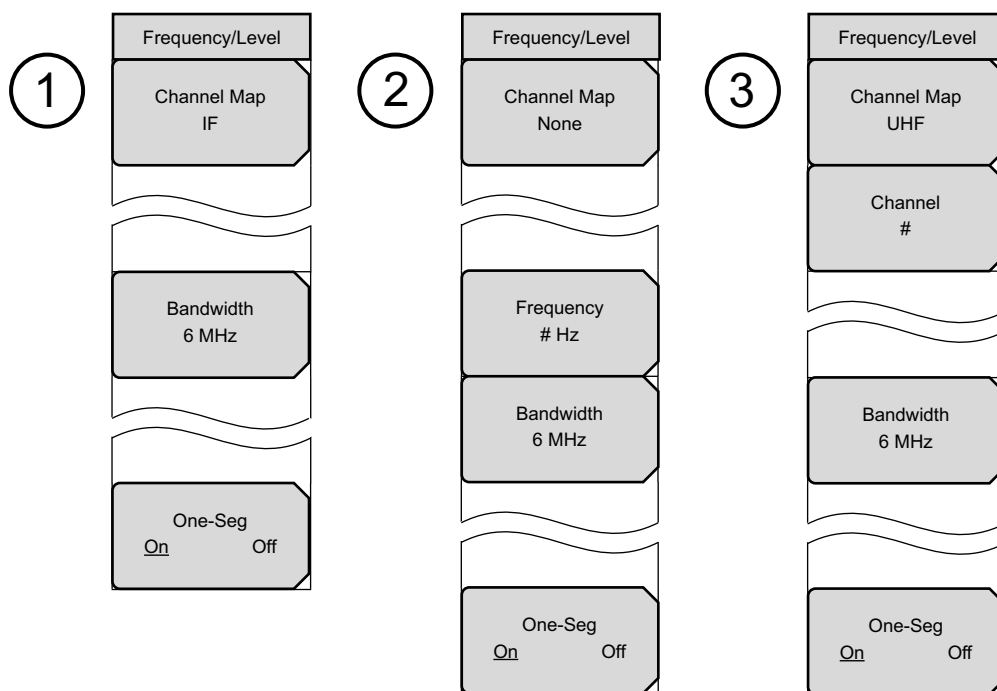


Figure 4-31. Frequency/Level Menus for Easy

1	IF Channel Map, Easy Setup
2	No Channel Map (set to None), Easy Setup
3	UHF or UHF (Brazil) Channel Map, Easy Setup

Measurement Selection Menus

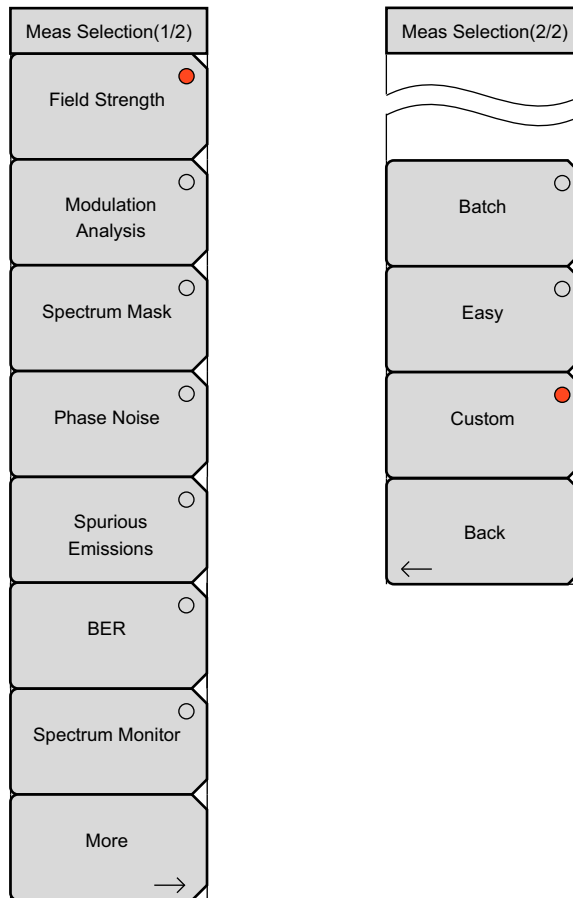


Figure 4-32. Measurement Selection Menus for Custom and Easy

While in Easy Measurement mode or Custom Measurement mode, press the **Meas Selection** main menu key to open the Meas Selection (1/2) menu, then press the **More** submenu key to open the **Meas Selection (2/2)** menu. These two menus have the same submenu keys in both Custom Measurement mode and Easy Measurement mode.

While in Batch Measurement mode the **Meas Selection** menu (shown in [Figure 4-40 on page 4-66](#)) is the only menu that is available when pressing the **Meas Selection** main menu key.

Field Strength Setup Menu Group

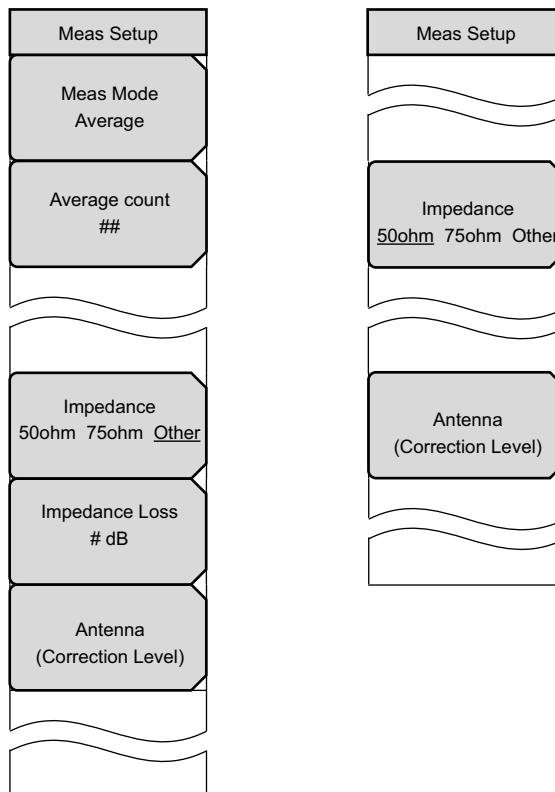
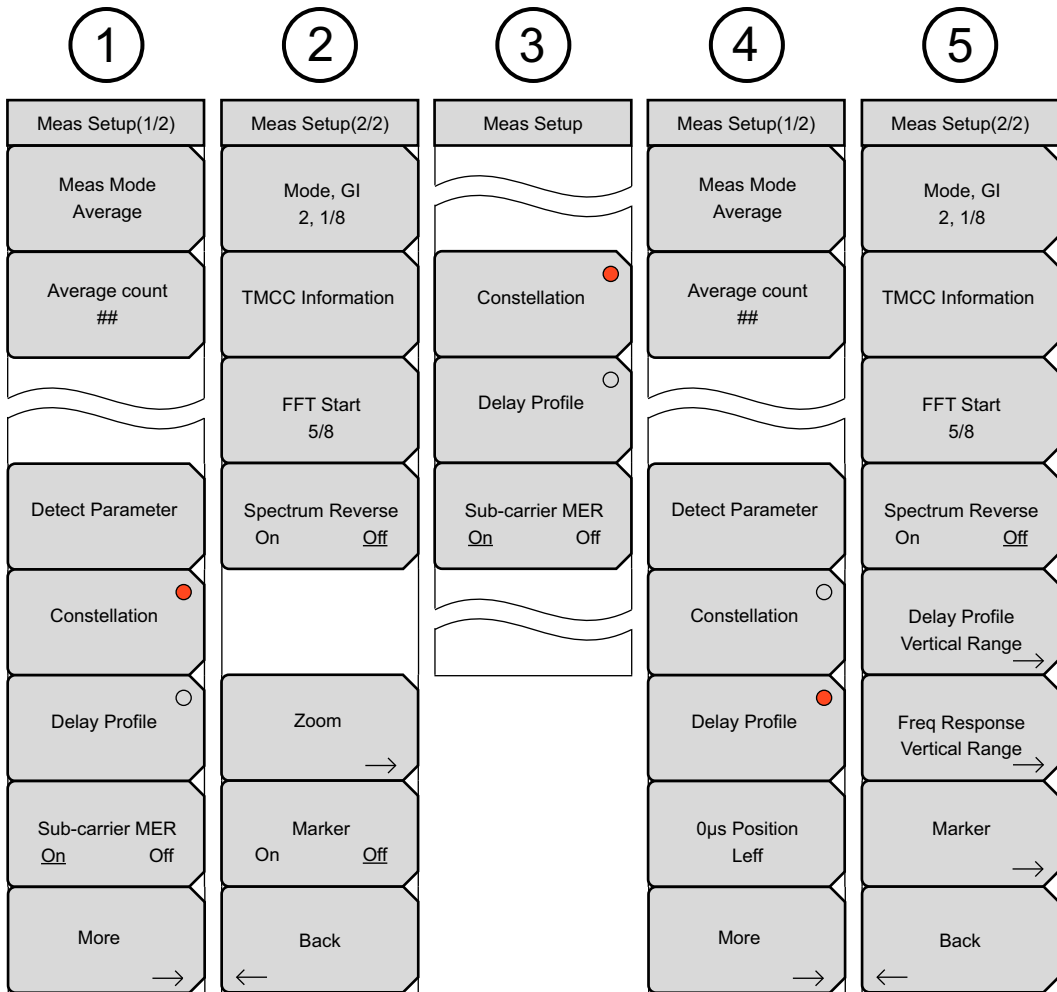


Figure 4-33. Field Strength Measurement Setup Menus for Custom and Easy

While preparing for a Field Strength measurement in Easy Measurement mode or Custom Measurement mode, press the **Meas Setup** main menu key to open the Meas Setup menu. The **Meas Mode** submenu key is not available in Easy Measurement mode, which uses continuous measurement only.

Modulation Analysis Setup Menu Group



1	Constellation, first menu, Custom
2	Constellation, second menu, Custom
3	Easy Measurement Setup
4	Delay Profile, first menu, Custom
5	Delay Profile, second menu, Custom

Figure 4-34. Modulation Analysis Setup Menus for Custom and Easy

When the measurement selection is Modulation Analysis, the Meas Setup menu for Easy Measurement mode displays the Sub-carrier MER submenu key only when the Constellation measurement view is selected. When Delay Profile measurement view is selected, only 2 submenu keys are displayed (Constellation and Delay Profile).

Constellation Setup (Modulation Analysis) Menu Group

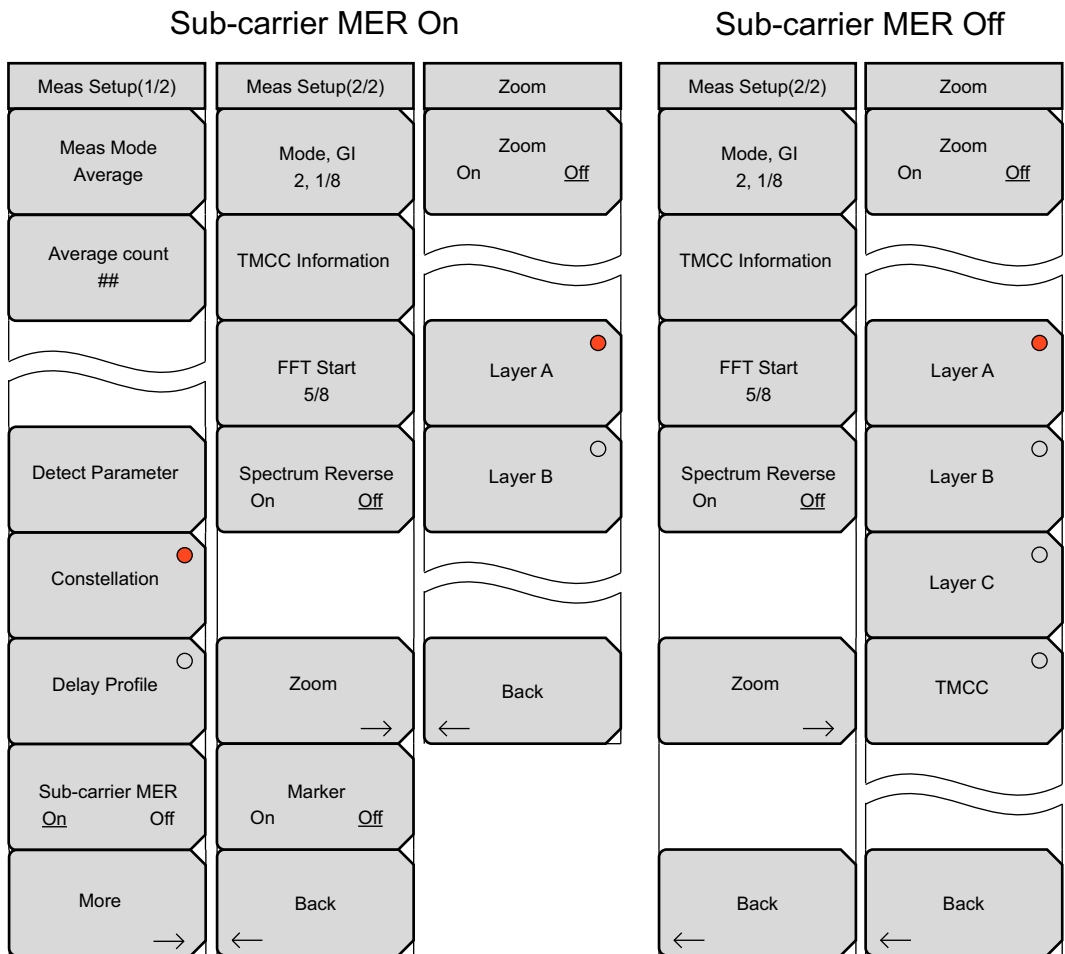
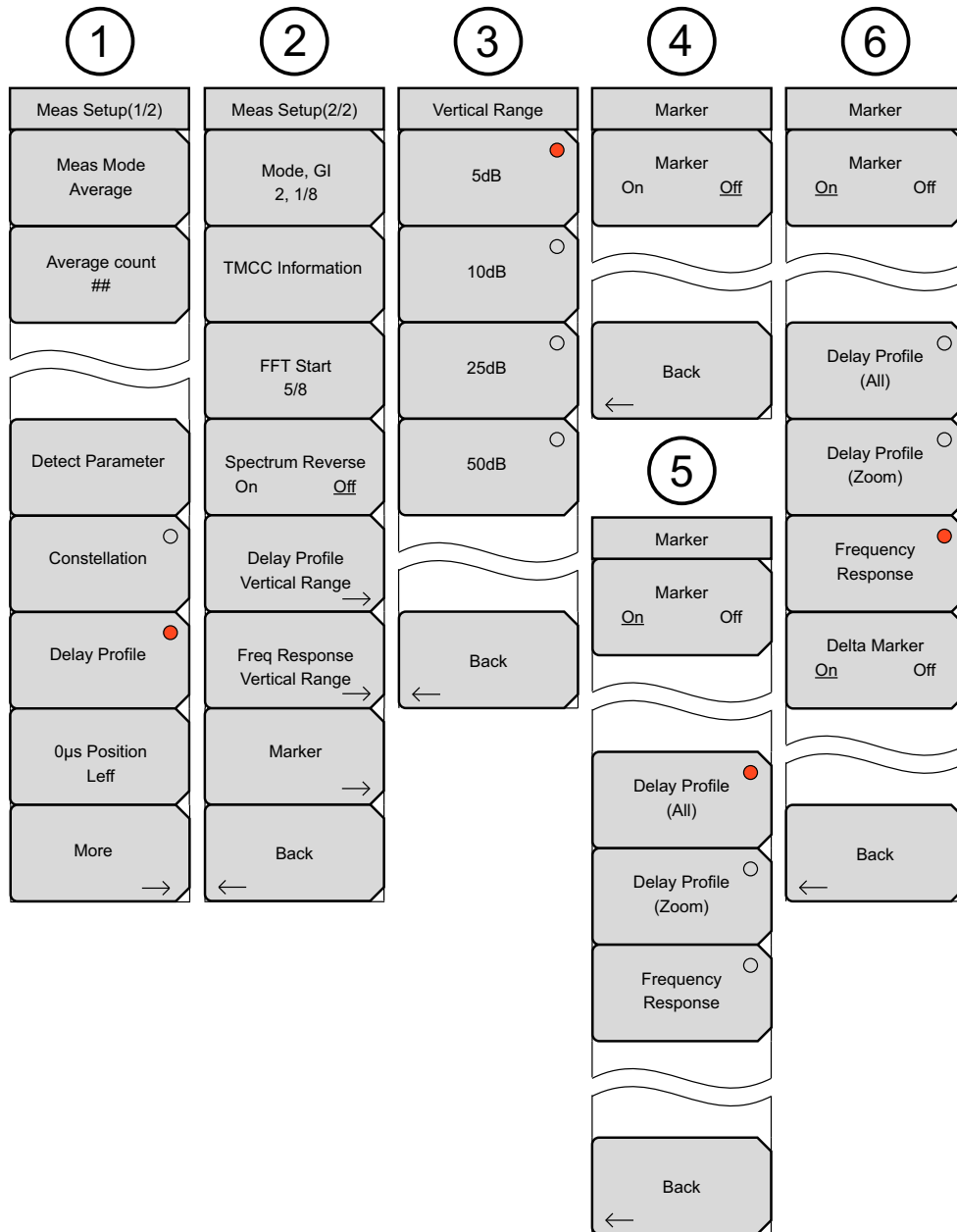


Figure 4-35. Constellation Setup and Zoom Menus — Custom

Delay Profile Setup (Modulation Analysis) Menu Group



1	Delay Profile selected and 0 µS Position displayed
2	Delay Profile setup
3	Delay Profile and Freq Response Vertical Range (same submenu keys, different functions)
4	Marker menu, Marker Off
5	Marker menu, Marker On
6	Delta Marker menu, Marker displayed when Frequency Response is selected

Figure 4-36. Delay Profile Setup Menus — Custom

BER Measurement Menu Group

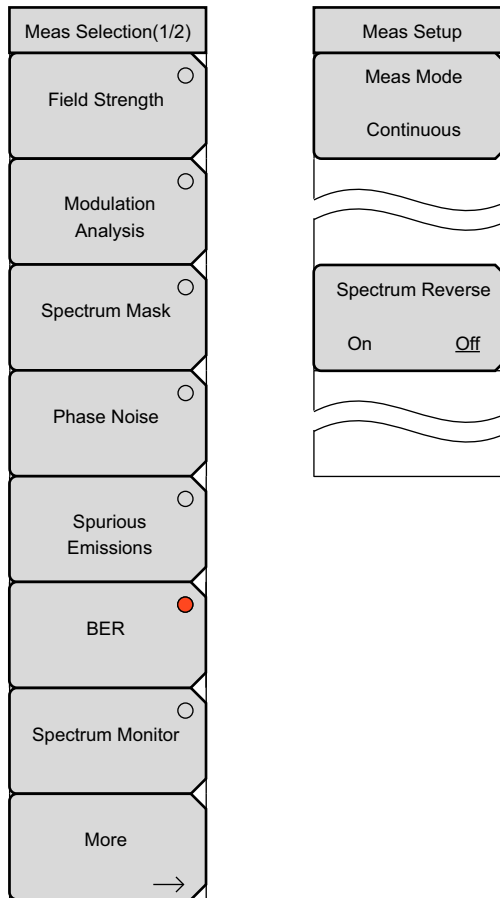


Figure 4-37. ISDB-T BER Menus — Custom

4-20 Measurement Selection Menus

Meas Selection (1/2) Menu (Custom and Easy)

Select from this menu one of the seven measurement types: Field Strength, Modulation Analysis, Spectrum Mask, Phase Noise, Spurious Emissions, BER, or Spectrum Monitor. Your selection determines the list of submenu keys that will be displayed in the Meas Setup menu. A red circle at the upper right of a submenu key denotes the active measurement.

Key Sequence: **Meas Selection**









Meas Selection(1/2)	
Field Strength 	Field Strength: Press this submenu key to begin Field Strength measurements and to display the Field Strength measurement screen.
Modulation Analysis 	Modulation Analysis: Press this submenu key to begin Modulation Analysis measurements and to display the Modulation Analysis measurement screen.
Spectrum Mask 	Spectrum Mask: Press this submenu key to begin Spectrum Mask measurements and to display the Spectrum Mask measurement screen.
Phase Noise 	Phase Noise: Press this submenu key to begin Phase Noise measurements and to display the Phase Noise measurement screen.
Spurious Emissions 	Spurious Emissions: Press this submenu key to begin Spurious Emissions measurements and to display the Spurious Emissions measurement screen.
BER 	BER: Press this submenu key to enable BER measurements and to display the BER Measurement screen. This submenu key is displayed only if Option 79 is installed.
Spectrum Monitor 	Spectrum Monitor: Press this submenu key to begin Spectrum Monitor measurements and to display the Spectrum Monitor measurement screen.
More 	More: Press this submenu key to open the “Meas Selection (2/2) Menu (Custom and Easy)” on page 4-65.

Figure 4-38. Measurement Selection (1/2) Menu (Custom and Easy)

Meas Selection (2/2) Menu (Custom and Easy)

While in Custom or Easy Measurement mode, this Meas Selection (2/2) menu is available from the “[Meas Selection \(1/2\) Menu \(Custom and Easy\)](#)” on page 4-64. When in Batch Measurement mode, this is the only Meas Selection menu that is available when you press the **Meas Selection** main menu key.

Key Sequence (in Custom or Easy Measurement mode): **Meas Selection** > More

Key Sequence (in Batch Measurement mode): **Meas Selection**

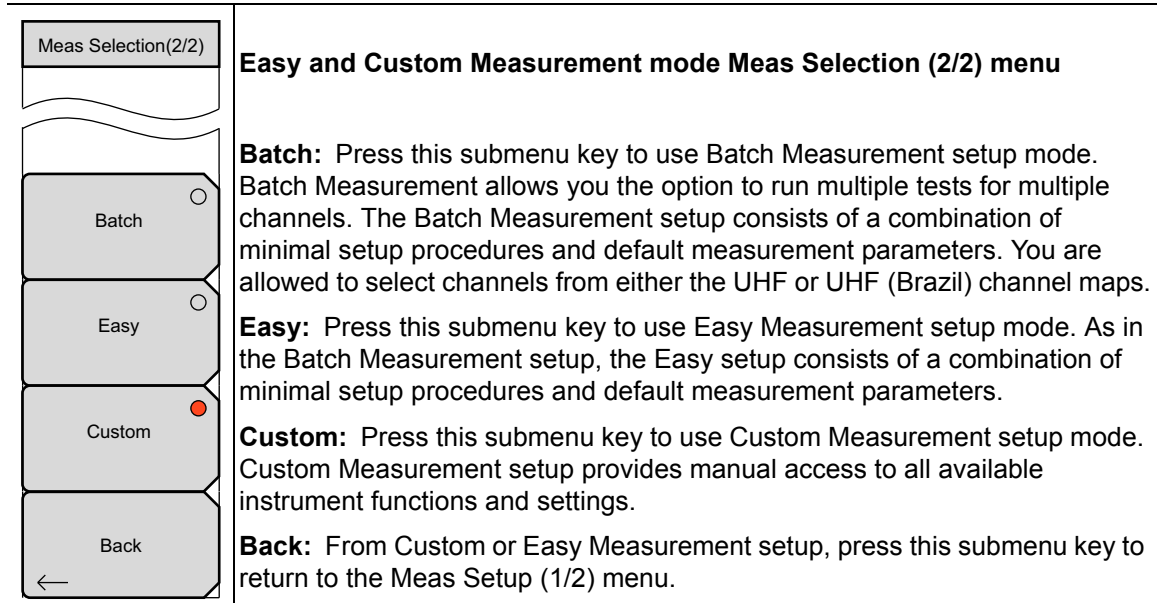


Figure 4-39. Measurement Selection (2/2) Menu (Custom and Easy)

Measurement Mode Selection Menus

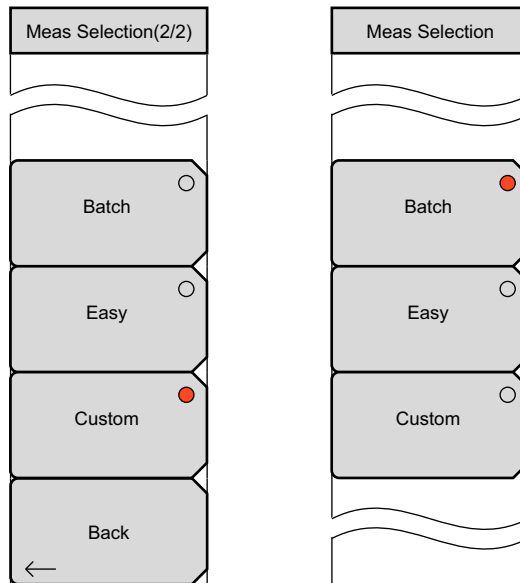


Figure 4-40. Measurement Selection Menus — Custom, Easy, or Batch

While in Batch Measurement mode this **Meas Selection** menu (in [Figure 4-40](#)) is the only menu that is available when pressing the **Meas Selection** main menu key.

While in Easy Measurement mode or Custom Measurement mode, press the **Meas Selection** main menu key to open the Meas Selection (1/2) menu, then press the **More** submenu key to open the **Meas Selection (2/2)** menu.

4-21 Field Strength Measurement Setup Menus

In the Meas Setup menu, the submenu keys that are available depend upon the measurement mode (Easy or Custom) and depend upon individual submenu key settings. The Average Count submenu key is displayed only when the Meas Mode is set to Average or Moving Average. The Impedance Loss submenu key is displayed only when the Impedance is set to Other. The Meas Mode submenu key is not displayed for the Easy measurement mode.

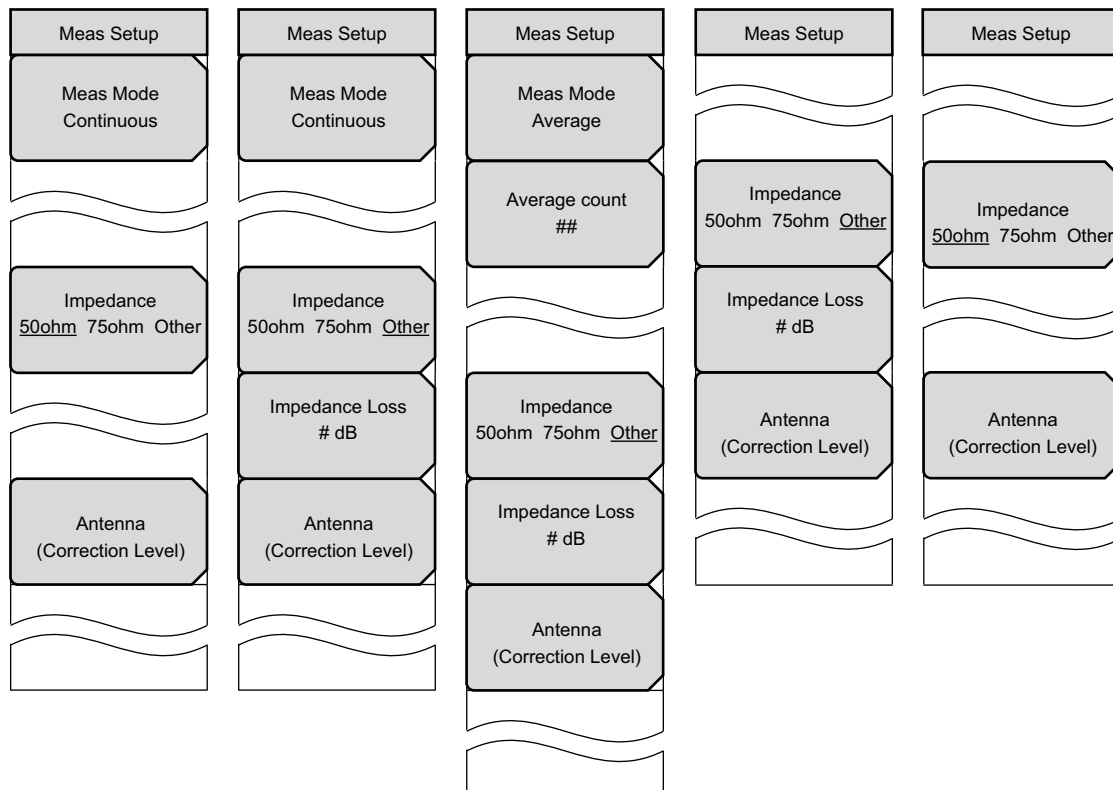


Figure 4-41. Meas Setup Menus for Field Strength Measurements — Custom and Easy

4-22 Measurements in Custom Mode

Custom Measurement mode setup provides manual access to all available instrument functions and settings. Optional values for all of the measurement parameters can be set. The menus that are displayed in this measurement mode offer the most user options for manual setup.

4-23 Frequency/Level Menus (Custom Mode)

These menus describe the Custom mode **Frequency/Level** menus for the Channel Map options: UHF, UHF (Brazil), IF, or None.

Frequency/Level Menu for UHF Channel Map

Custom

Key Sequence: **Frequency/Level** > Channel Map > UHF or UHF (Brazil)

Frequency/Level	Channel Map: Press this submenu key to open the Select Channel Map list box to choose one of four options: UHF, UHF (Brazil), IF, or None. Selecting UHF or UHF (Brazil) displays the Channel submenu key to select a channel and its corresponding frequency.
Channel Map UHF	Channel: This submenu key is displayed only when Channel Map is set to UHF. Press this submenu key to open the Channel Editor dialog box. For UHF, the channel range is 13 to 62. For UHF (Brazil), the channel range is 14 to 69. Selection of a channel automatically sets the corresponding frequency.
Channel #	Bandwidth: Press this submenu key to open the Select Bandwidth list box and manually select a bandwidth: 6 MHz or 8 MHz.
Bandwidth 6 MHz	Auto Reference Level: Press this submenu key to automatically set the reference level at an optimal value. Refer to “Auto Reference Level” on page 4-72 .
Auto Reference Level	Reference Level: Press this submenu key to open the Reference Level Editor dialog box to manually select a signal reference value. If the Pre Amp submenu key is On, then the reference level range is from –10 dBm to –50 dBm in increments of 10 dB. If the Pre Amp submenu key is Off, then the reference level range is from –25 dBm to +20 dBm in increments of 5 dB.
Reference Level # dBm	Pre Amp
Pre Amp <u>On</u> Off	On Off: Press this submenu key to toggle the Pre Amp setting to On and Off. The current state is underlined. When the preamplifier is switched On, the reference level is automatically set to –30 dBm. When the preamplifier is switched Off, the reference level is set to –25 dBm. Refer to the Pre Amp Warning on page 4-69 .
One-Seg <u>On</u> Off	One-Seg: Press this submenu key to toggle the one-segment view On or Off. You can view the One-Seg Frequency Response measurement in Delay Profile or in Constellation and Sub-Carrier MER charts when the One-Seg submenu key is On. Refer to Figure 4-15 on page 4-33 .

Figure 4-42. Frequency/Level Menus for UHF or UHF (Brazil) Channel Map

Warning

The upper limit level, up to which the instrument is not damaged, depends on the preamplifier state.

Preamplifier On: –10 dBm

Preamplifier Off: +20 dBm

Switching the preamplifier On, while applying greater than –10 dBm with preamplifier Off, may damage the internal electronic circuit. Pay attention to the input level when switching the preamplifier On or Off while applying a signal.

Table 4-16. Preamplifier Reference Level, Range, and Setting Resolution

Preamplifier State	Reference Level Range	Reference Level Setting Resolution
On	–50 dBm to –10 dBm	10 dB
Off	–25 dBm to 20 dBm	5 dB

Frequency/Level Menu for IF Channel Map

Custom

Key Sequence: **Frequency/Level** > Channel Map > IF

Frequency/Level	Channel Map: Press this submenu key to open the Select Channel Map list box to choose one of four options: UHF, UHF (Brazil), IF, or None. Selecting IF sets the frequency to 37.15 MHz, and Spectrum Reverse is automatically turned on.
Channel Map IF	Bandwidth: Press this submenu key to open the Select Bandwidth list box and manually select a bandwidth: 6 MHz or 8 MHz.
Bandwidth 6 MHz	Auto Reference Level: Press this submenu key to automatically set the reference level at an optimal value. Refer to “Auto Reference Level” on page 4-72 .
Auto Reference Level	Reference Level: Press this submenu key to open the Reference Level Editor dialog box to manually select a signal reference value. If the Pre Amp submenu key is On, then the reference level range is from –10 dBm to –50 dBm in increments of 10 dB. If the Pre Amp submenu key is Off, then the reference level range is from –25 dBm to +20 dBm in increments of 5 dB.
Reference Level # dBm	Pre Amp On Off: Press this submenu key to toggle the Pre Amp setting to On and Off. The current state is underlined. When the preamplifier is switched on, the reference level is automatically set to –30 dBm. When the preamplifier is switched off, the reference level is set to –25 dBm. Refer to the Pre Amp Warning on page 4-69 .
Pre Amp <u>On</u> Off	One-Seg: Press this submenu key to toggle the one-segment view On or Off. You can view the One-Seg Frequency Response measurement in Delay Profile or in Constellation and Sub-Carrier MER charts when the One-Seg submenu key is On. Refer to Figure 4-15 on page 4-33 .
One-Seg <u>On</u> Off	

Figure 4-43. Frequency/Level Menu for IF Channel Map

Frequency/Level Menu for Channel Map Setting of None

Custom

Key Sequence: **Frequency/Level** > Channel Map > None

Frequency/Level	Channel Map: Press this submenu key to open the Select Channel Map list box to choose one of four options: UHF, UHF (Brazil), IF, or None. Selecting None displays the Frequency submenu key to allow manually configuring frequency.
Channel Map None	Frequency: This submenu key is displayed only when Channel Map is set to None. Press this submenu key to open the Frequency Edit Dialog box and manually set a frequency within a specified range that is displayed in the window. The submenu key menu displays Units: GHz, MHz, kHz, and Hz.
Frequency # Hz	Bandwidth: Press this submenu key to open the Select Bandwidth list box and manually select a bandwidth: 6 MHz or 8 MHz.
Bandwidth 6 MHz	Auto Reference Level: Press this submenu key to automatically set the reference level at an optimal value. Refer to “Auto Reference Level” .
Auto Reference Level	Reference Level: Press this submenu key to open the Reference Level Editor dialog box to manually select a signal reference value. If the Pre Amp submenu key is On, then the reference level range is from –10 dBm to –50 dBm in increments of 10 dB. If the Pre Amp submenu key is Off, then the reference level range is from –25 dBm to +20 dBm in increments of 5 dB.
Reference Level # dBm	Pre Amp
Pre Amp <u>On</u> Off	On Off: Press this submenu key to toggle the Pre Amp setting to On and Off. The current state is underlined. When the preamplifier is switched on, the reference level is automatically set to –30 dBm. When the preamplifier is switched off, the reference level is set to –25 dBm. Refer to the Pre Amp Warning on page 4-69 .
One-Seg <u>On</u> Off	One-Seg: Press this submenu key to toggle the one-segment view On or Off. You can view the One-Seg Frequency Response measurement in Delay Profile or in Constellation and Sub-Carrier MER charts when the One-Seg submenu key is On. Refer to Figure 4-15 on page 4-33 .

Figure 4-44. Frequency/Level Menus for Channel Map Setting of None

Auto Reference Level

The reference level indicates the signal level that is supplied to the instrument.

The reference level range for input to the instrument is determined by the reference level setting. Immediately after a signal is applied to the instrument, the input attenuator is automatically set according to the reference level. The relationship between the reference level and the input attenuator is fixed.

Raising the reference level increases attenuation of the input attenuator, enabling you to measure signals with higher input levels. Note that the noise floor rises in proportion to the attenuation of the input attenuator.

When applying a signal to the instrument, input a signal level that does not exceed the reference level value. If the signal level exceeds the reference level, raise the reference level. For example, if the signal level is 0.5 dBm with preamplifier off, then set the reference level to 5 dBm, not to 0 dBm.

If an interfering wave other than the intended signal exists, and if the power within the frequency range of approximately 100 kHz to 7.1 GHz is 15 dB or more higher than the measurement signal level, then set the reference level to take the large signal into account.

4-24 Meas Setup Menu – Field Strength

Custom

Key Sequence: **Meas Setup**

Meas Setup	Meas Mode: Press this submenu key to open the Select Meas Mode list box. Highlight a measurement mode and press the Enter key. Refer to Section 4-25 “Select Meas Mode List Box (Custom)” on page 4-74.
Meas Mode Average	
Average count ##	Average Count: Press this submenu key to open the Average Count Editor edit box and set the Average Count. The setting is displayed on the submenu key.
<hr/>	
Impedance 50ohm 75ohm <u>Other</u>	Impedance 50ohm 75ohm Other: Press this submenu key to toggle through the 3 settings. The current setting is underlined. The instrument impedance is 50 ohms by default. This can be changed to 75 ohms by using the Anritsu external impedance converter, part number 12N50-75B. Select Other when you are not using the Anritsu 12N50-75B impedance converter. Refer to Section 4-26 “Instrument Impedance or External Impedance” on page 4-76.
Impedance Loss # dB	Impedance Loss: This submenu key is displayed only when the Impedance submenu key is set to Other. Press this submenu key to open the Impedance Loss Editor edit box and set a dB value.
Antenna (Correction Level)	Set the impedance loss in the range of 0.0 dB to 100.0 dB (in 0.1 dB steps) when the impedance is set to Other (75 ohms). Set 1.9 dB when using the MA1621A impedance transformer as the impedance converter. Antenna (Correction Level): Press this submenu key to open the Select Antenna list box. Choose an antenna and press the Enter key. For additional details, refer to Section “Antenna Setup” on page 4-5.

Figure 4-45. Meas Setup Menu – Field Strength

4-25 Select Meas Mode List Box (Custom)

Field Strength Measurement Mode

In the Custom Field Strength measurement mode, 5 options are available in this list box: Single, Continuous, Average, Moving Average, and Max Hold.

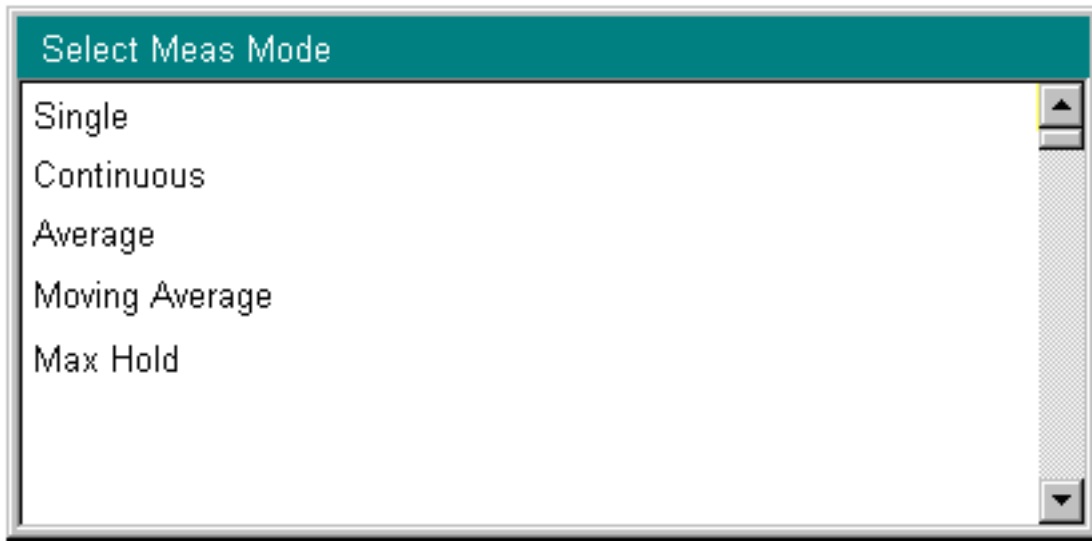


Figure 4-46. Select Measure Mode List Box – Field Strength

Single: Sets the test for one measurement. Acquires the measurement and displays the results to the screen. This mode is useful for screen capture.

Continuous: Sets the test to take measurements continuously. Results are updated on the screen. This mode is helpful for real-time signal analysis.

Average: Averages the measurement results for the specified number of measurements set in Average Count. During the measurement, the status bar at the top of the screen displays the current measurement count and average count set. The screen displays the average of the measurements results after the final count, as shown in [Figure 4-47](#). Refer to “Average Count” on page 4-75.



Figure 4-47. Status Bar

Moving Average: Takes the number of measurements that are set in Average Count. Then an average result is calculated from those measurements and displayed on the screen. Another measurement is taken, and another average is calculated from the last number of measurements set in Average Count. Screen updates. For example, if Average Count is set to 5, and if m is a measurement and r is an average result displayed to the screen, then the first four calculations are made as follows:

$$(m_1 + m_2 + m_3 + m_4 + m_5) / 5 = r_1$$

$$(m_2 + m_3 + m_4 + m_5 + m_6) / 5 = r_2$$

$$(m_3 + m_4 + m_5 + m_6 + m_7) / 5 = r_3$$

$$(m_4 + m_5 + m_6 + m_7 + m_8) / 5 = r_4$$

This mode is useful while aiming the antenna.

Average Count: Opens the Average Count Editor edit box (Figure 4-48). Set the number of measurements that are to be taken for the Average and Moving Average measure modes. When Single, Continuous, or Max Hold is selected as the measurement mode, this submenu key is not displayed.

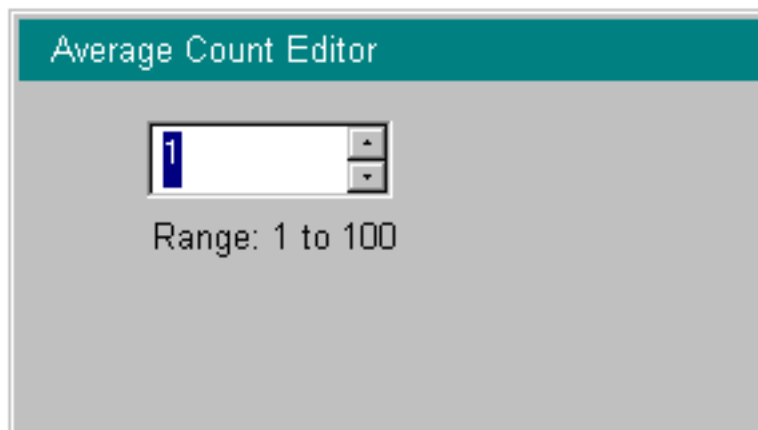


Figure 4-48. Average Count Editor Edit Box

Max Hold: Repeats the measurement and holds the maximum value.

Modulation Analysis Measurement Mode

In the Custom Modulation Analysis measurement mode, 5 options are available in the Select Meas Mode list box: Single, Continuous, Average, Moving Average, and Overwrite. The first 4 options are described above (they are the same as in the Field Strength measurement).

Overwrite: This measurement mode is available only in Modulation Analysis with the Constellation setting. In this mode, the instrument displays the next measurement result without deleting the previous constellation.

Phase Noise Measurement Mode

In the Phase Noise measurement mode, 3 options are available in the Select Meas Mode list box: Single, Continuous, and Average. They are as described above.

Spectrum Monitor Measurement Mode

In the Spectrum Monitor measurement mode, 2 options are available in the Select Meas Mode list box: Single and Continuous. They are as described in the previous Field Strength section, “[Single](#)” and “[Continuous](#)” on page 4-74.

4-26 Instrument Impedance or External Impedance

The instrument impedance is 50 ohms by default. This can be changed to 75 ohms by using the Anritsu external impedance converter, part number 12N50-75B, which is designed for DC to 3000 MHz.

50 ohms: Select this impedance when no converter is used. Impedance loss is automatically set to 0.0 dB.

75 ohms: For example, select this impedance when Anritsu part number 12N50-75B is used. Impedance loss is automatically set to 7.5 dB.

Other: Set this impedance (also 75 ohms) when an impedance converter other than Anritsu part number 12N50-75B is used. Set the insertion loss for the impedance converter that you are using.

4-27 Meas Setup (1/2) Menu - Modulation Analysis

Custom

Key Sequence: **Meas Selection** > Modulation Analysis > **Meas Setup**

Meas Setup(1/2)	<p>Meas Mode: Press this submenu key to open the Select Meas Mode list box. Highlight a measurement mode and press the Enter key. Refer to Section 4-25 “Select Meas Mode List Box (Custom)” on page 4-74.</p>
Meas Mode Average	<p>Average Count: Press this submenu key to open the Average Count Editor edit box to set the Average Count. The setting is displayed on the submenu key. This submenu key is displayed only when Meas Mode is set to Average or to Moving Average.</p>
Average count ##	<p>Detect Parameter: Press this submenu key to allow the instrument to automatically determine the Mode, GI and TMCC Information based upon the incoming signal that the instrument is detecting. Measurement begins as soon as the parameters are detected. Refer to Section 4-12 “Modulation Analysis, Custom” on page 4-22, Section 4-34 “Common Modulation Keys in Meas Setup (2/2) menu” on page 4-85, and Section 1-6 “Digital Television Signal Analyzer Technology” on page 1-4.</p>
Detect Parameter	<p>Constellation: Press this submenu key to display a Constellation view of the measurement information. The Meas Setup (2/2) menu (opened by pressing the More submenu key) provides settings to configure the Modulation measurement, allowing you to display the Constellation measurement display along with the Frequency Offset, CH Power, MER, and TMCC Info.</p>
Constellation	<p>Delay Profile: Press this submenu key to display a Delay Profile view of the measurement information. The Meas Setup (2/2) menu (opened by pressing the More submenu key) provides settings to configure the Delay Profile measurement, allowing you to display the Delay Profile frequency response, frequency offset, and MER.</p>
Delay Profile	<p>Sub-carrier MER <u>On</u> Off</p> <p>Sub-carrier MER On Off: Press this submenu key to toggle the Sub-carrier MER measurement On and Off. The current state is underlined. This submenu key is displayed only when Constellation is active. The associated MER graph is displayed in the constellation display when this submenu key set to On. It replaces the Layer C and TMCC graphs.</p>
Sub-carrier MER <u>On</u> Off	<p>More: Press this submenu key to open the Meas Setup (2/2) menu. The first four submenu keys of the Meas Setup (2/2) menu are common to both Constellation and Delay Profile configuration. The last four submenu keys differ for Constellation and Delay Profile measurement setups.</p>
More	

Figure 4-49. Modulation Analysis Setup Menu (1/2)

4-28 Meas Setup Menu - Modulation Analysis

Easy

Key Sequence: **Meas Selection** > Modulation Analysis > **Meas Setup**



Meas Setup	
Constellation 	<p>Constellation: Press this submenu key to display a Constellation view of the measurement information. The red circle on the face of the submenu key indicates that this selection is active. This selection also enables the Sub-carrier MER submenu key.</p>
Delay Profile 	<p>No other configuration is necessary.</p>
Sub-carrier MER <u>On</u> Off	<p>Delay Profile: Press this submenu key to display a Delay Profile view of the measurement information. No other configuration is necessary.</p>
	<p>Sub-carrier MER On Off: Press this submenu key to toggle the Sub-carrier MER measurement On and Off. The current state is underlined. This submenu key is displayed only when Constellation is active. The associated MER graph is displayed in the constellation display when this submenu key set to On. It replaces the Layer C and TMCC graphs.</p>

Figure 4-50. Modulation Analysis Measurement Setup Menu (Easy Measurement)

4-29 Modulation Constellation Configuration Menu

Custom

Key Sequence: **Meas Selection** > Modulation Analysis > **Meas Setup** > Constellation > More

Meas Setup(2/2)	
Mode, GI 2, 1/8	
TMCC Information	
FFT Start 5/8	
Spectrum Reverse On <u>Off</u>	
Zoom →	<p>Zoom: Press this submenu key to display the “Constellation Zoom Menus” on page 4-80 and to configure the Zoom parameters. This submenu key is displayed for all Constellation measurement modes except for Overwrite (refer to “Overwrite (Constellation Only)” on page 4-30).</p> <p>While either the Meas Setup (2/2) menu or the Zoom menu is displayed, the Zoom On/Off feature can be toggled On and Off by pressing the Enter key. The graph that is enlarged when Zoom is On is the graph that is selected in the Zoom menu.</p>
Marker On <u>Off</u>	<p>Marker On Off: This submenu key is displayed only when sub-carrier MER is On. Press this submenu key to toggle the Marker On and Off. The current state is underlined.</p> <p>When the Marker is On, a green diamond marker is displayed in the Sub-carrier MER graph. Use the Left/Right and Up/Down arrow keys and the rotary knob to move the marker. The marker position and frequency and also the dB value are displayed in green text in the upper-right corner of the Sub-carrier MER graph.</p>
Back ←	<p>The upper line displays the sub-carrier number and the frequency (offset from the channel center frequency) at the marker location.</p> <p>Back: Press this submenu key to return to the Meas Setup (1/2) menu.</p>

Figure 4-51. Modulation Analysis Constellation Setup Menu (2/2)

4-30 Constellation Zoom Menus

Custom

Key Sequence: **Meas Selection** > Modulation Analysis > **Meas Setup** > Constellation > More > Zoom

Also, Sub-carrier MER is toggled to the On state.

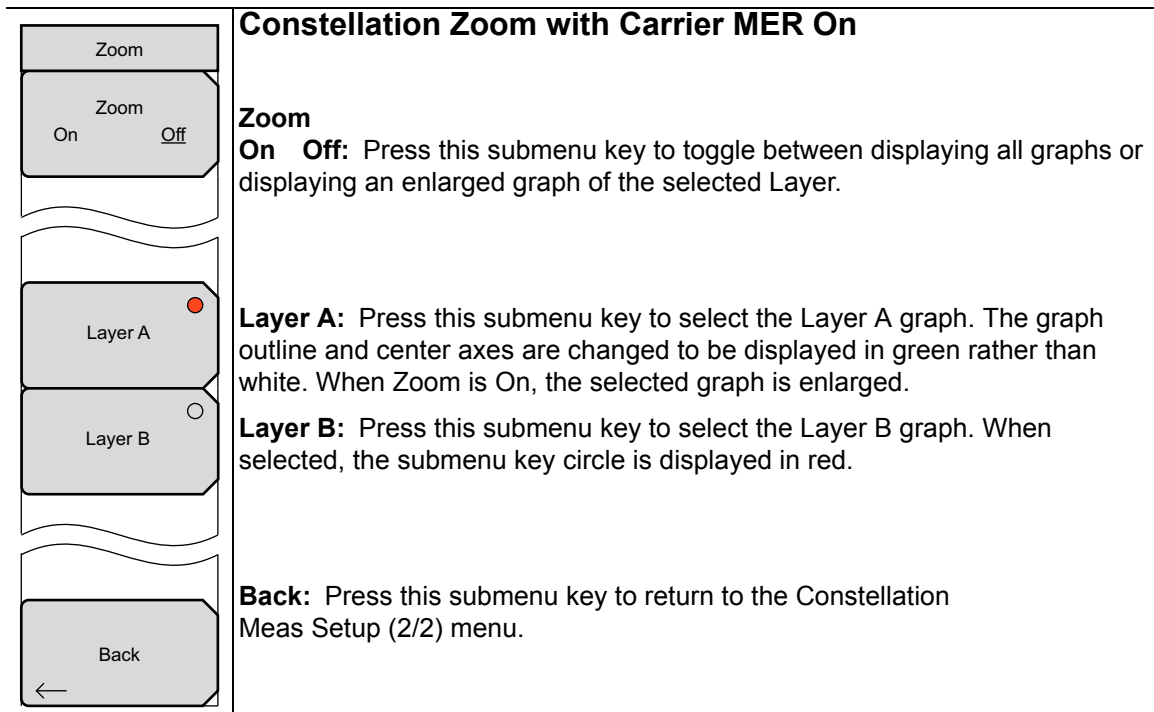


Figure 4-52. Modulation Analysis Constellation Zoom Menu (Sub-carrier MER On)

While either the Meas Setup (2/2) menu or the Zoom menu is displayed, the Zoom On/Off feature can be toggled On and Off by pressing the **Enter** key. The graph that is enlarged when Zoom is On is the graph that is selected in the Zoom menu.

Constellation Zoom Menus (continued)

The Zoom feature is used to enlarge one graph. The Layer submenu keys are used to select the layer that will be enlarged by using Zoom. The active Layer submenu key displays a red circle, and its graph outline and center axes are changed to be displayed in green rather than white.

Key Sequence: **Meas Selection** > Modulation Analysis > **Meas Setup** > Constellation > More > Zoom

Also, Sub-carrier MER is toggled to the Off state.

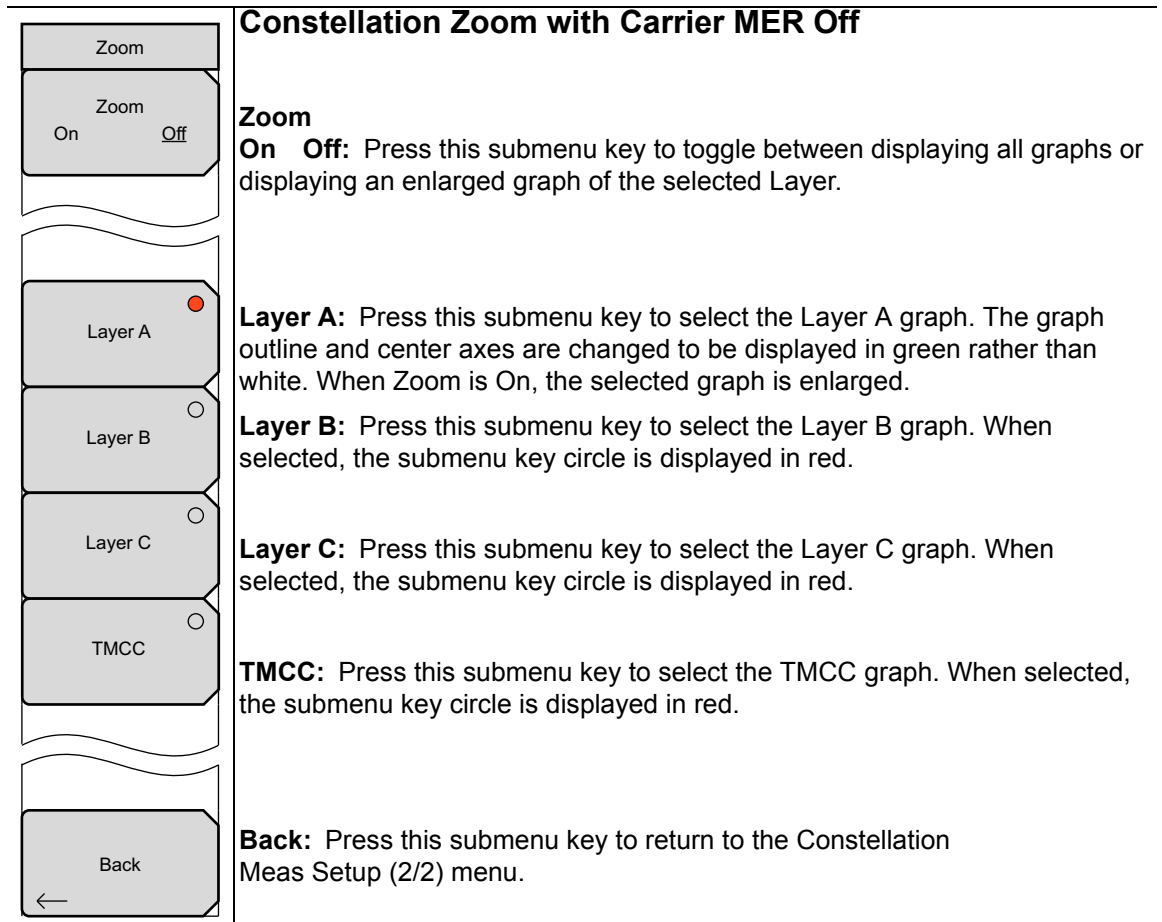


Figure 4-53. Modulation Analysis Constellation Zoom Menu (Sub-carrier MER Off)

While either the Meas Setup (2/2) menu or the Zoom menu is displayed, the Zoom On/Off feature can be toggled On and Off by pressing the **Enter** key. The graph that is enlarged when Zoom is On is the graph that is selected in the Zoom menu.

4-31 Modulation Delay Profile Configuration Menu

Custom

Key Sequence: **Meas Selection** > Modulation Analysis > **Meas Setup** > Delay Profile > More

Meas Setup(2/2)	
Mode, GI 2, 1/8	For descriptions of the top 4 submenu keys, refer to Section 4-34 “Common Modulation Keys in Meas Setup (2/2) menu” on page 4-85.
TMCC Information	
FFT Start 5/8	
Spectrum Reverse On Off	
Delay Profile Vertical Range →	Delay Profile Vertical Range: Press this submenu key to display the “ Delay Profile Vertical Range Menu ” on page 4-83, and then set the y-axis scale for both Delay Profile graphs.
Freq Response Vertical Range →	Freq Response Vertical Range: Press this submenu key to display the “ Delay Profile Freq Response Vertical Range Menu ” on page 4-84, and then set the y-axis scale for the Frequency Response graph.
Marker →	Marker: Press this submenu key to open the Marker menu.
Back ←	Back: Press this submenu key to return to the Meas Setup (1/2) menu.

Figure 4-54. Modulation Analysis Delay Profile Setup Menu (2/2)

4-32 Delay Profile Vertical Range Menu

Custom

Key Sequence:

Meas Selection > Modulation Analysis > **Meas Setup** > Delay Profile > More > Delay Profile Vertical Range

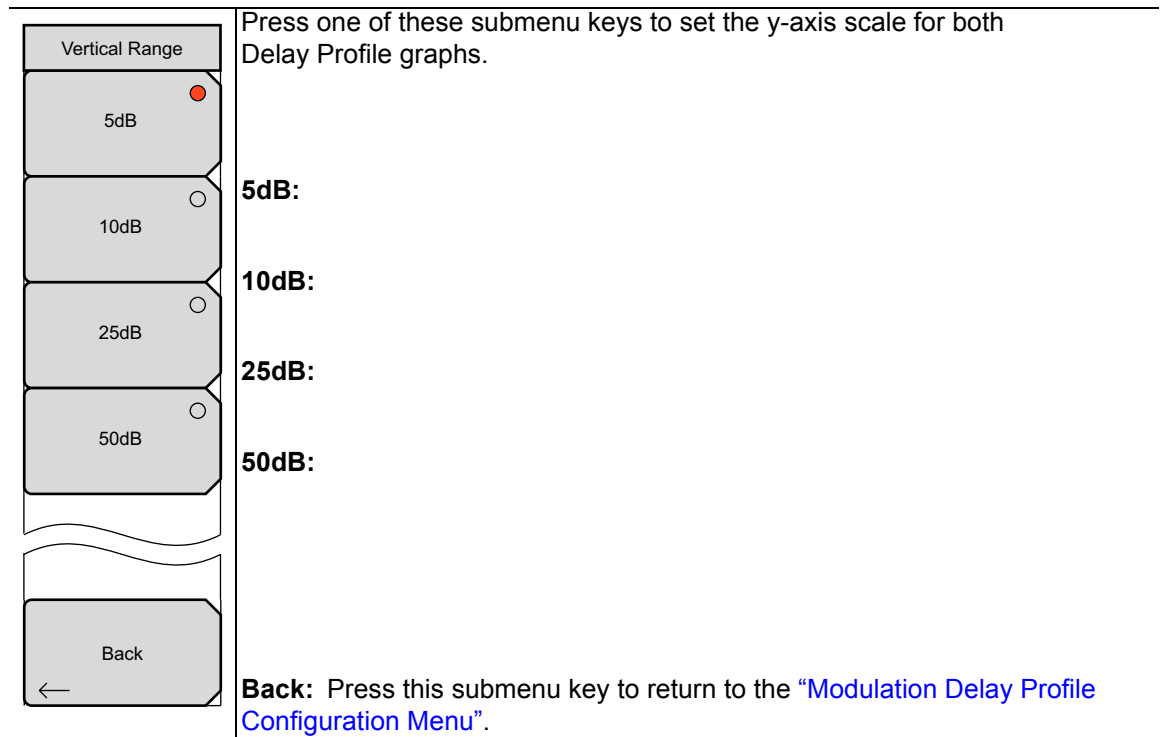


Figure 4-55. Modulation Analysis Delay Profile Vertical Range Menu

4-33 Delay Profile Freq Response Vertical Range Menu

Custom

Key Sequence:

Meas Selection > Modulation Analysis > **Meas Setup** > Delay Profile > More > Freq Response Vertical Range

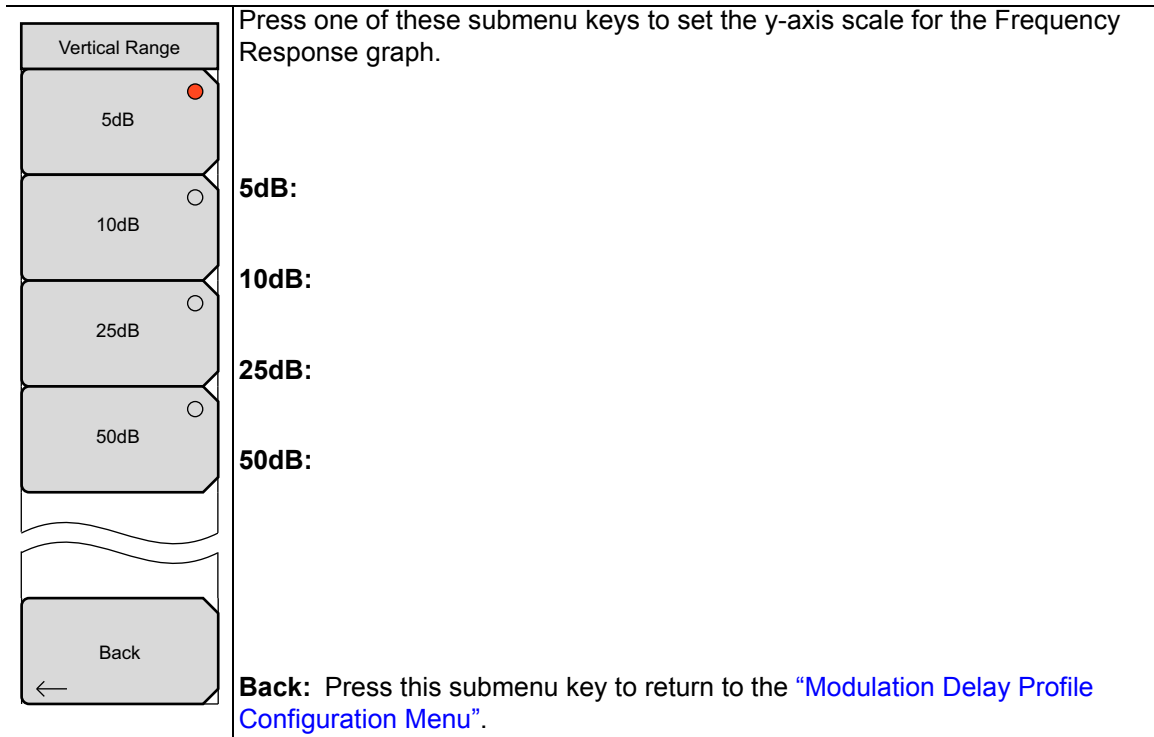


Figure 4-56. Modulation Analysis Delay Profile Freq Response Vertical Range Menu

4-34 Common Modulation Keys in Meas Setup (2/2) menu

Custom

Also refer to [Section 1-6 “Digital Television Signal Analyzer Technology”](#) on page 1-4.

Mode, GI

This submenu key opens the Select Mode, GI list box. Guard Intervals are used to ensure that distinct transmissions do not interfere with one another. The use of Guard Intervals introduces immunity to propagation delays, echoes, and reflection, to which digital data is normally very sensitive. Protection is inversely proportional to data rate efficiency. For example, a 1/4th guard interval (the largest choice) provides the best protection but also provides the lowest data rate efficiency.

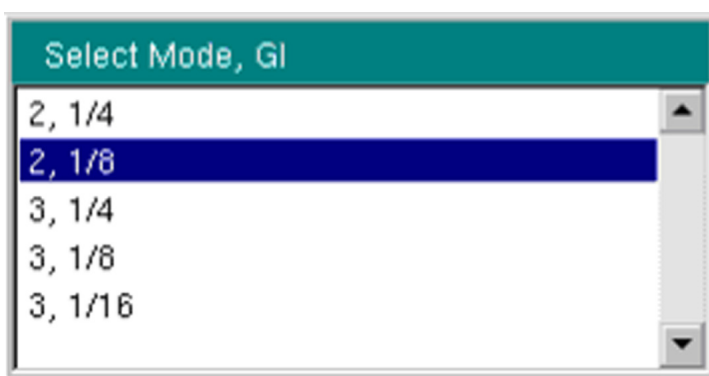


Figure 4-57. Select Mode, GI List Box

FFT Start

The instrument uses the FFT Start position to obtain the data that is used for measurement. The Select FFT Start list box allows selecting: 0/8, 1/8, 2/8, 3/8, 4/8, 5/8, 6/8, 7/8, 8/8 and 0/8 Fixed, 1/8 Fixed, 2/8 Fixed, 3/8 Fixed, 4/8 Fixed, 5/8 Fixed, 6/8 Fixed, 7/8 Fixed, 8/8 Fixed.

The relationship between FFT Start Position and GI is described in [Section 1-6 “Digital Television Signal Analyzer Technology”](#) on page 1-4 and in [Figure 1-3, “FFT Start and Guard Interval”](#) on page 1-8.

Using a 0/8 FFT Start position means that the instrument is measuring the Effective symbol, but is not including any portion of the Guard Interval.

Using a 1/8 FFT Start position means that the instrument is measuring the Effective symbol plus 1/8 of the Guard Interval. Stated in another way, an FFT Start of 1/8 means that the measurement starts with 1/8 of the Guard Interval and includes the complete Effective symbol.

Using a 2/8 FFT Start position means that the instrument is measuring the Effective symbol plus 2/8 of the Guard Interval.

Using an 8/8 FFT Start position means that the instrument is measuring the Effective symbol plus 8/8 (all) of the Guard Interval.

When only a segment of the Guard Interval is included in the measurement, the instrument is truncating the beginning of the guard interval before interpreting the effective symbol.

0/8 Fixed to 8/8 Fixed:

When a fixed FFT Start position is selected, the FFT Start position is fixed to one of the Guard Intervals (0/8, 1/8, 2/8, to 8/8).

Signals without interference can be cut out and measured by adjusting the FFT Start position. This allows separating the effective symbol from a delayed wave or a pre-ghost signal.

Spectrum Reverse

Spectrum Reverse is used to measure a signal in which the sub carrier location is inverted on the frequency axis, such as the IF signal of the transmitter.

TMCC Information (Custom)

Layer Segment setting: The total sum of segments for all three layers (A, B, and C) must add up to 13. Layer Modulation is 64QAM, 16QAM, or QPSK.

Layer	Segment	Modulation
Layer A	13 Range: 1 to 13	<input checked="" type="radio"/> 64QAM <input type="radio"/> 16QAM <input type="radio"/> QPSK
Layer B	0 Range: 0 to 12	<input checked="" type="radio"/> 64QAM <input type="radio"/> 16QAM <input type="radio"/> QPSK
Layer C	0 Range: 0 to 11	<input checked="" type="radio"/> 64QAM <input type="radio"/> 16QAM <input type="radio"/> QPSK

Figure 4-58. TMCC Information Editor Dialog Box

4-35 Marker Menu

Modulation Analysis, Delay Profile, Custom

Key Sequence:

Meas Selection > Modulation Analysis > **Meas Setup** > Delay Profile > More > Marker

Use arrow keys or rotary knob to move markers and delta markers.

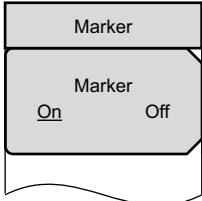
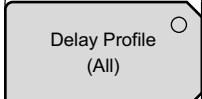
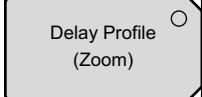
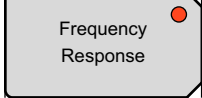

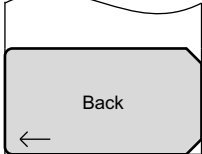
	<p>Marker On Off: Press this submenu key to toggle the marker On and Off. When On, the marker feature is displayed in the selected graph (submenu key with red circle). Also when On, the Delay Profile (All), Delay Profile (Zoom), and Frequency Response submenu keys are displayed.</p>
	<p>Delay Profile (All): Press this submenu key to enable this graph for marker configuration. The marker is a green highlighted rectangle. Use the arrow keys and the rotary knob to move the marker to the portion of the signal that you want to view in the Delay Profile (Zoom) graph.</p>
	<p>The Up/Down arrow keys move the maker approximately twice the distance as the Left/Right arrows or the rotary knob. The rectangular marker range, in microseconds, is displayed in the Delay Profile (Zoom) graph x-axis.</p>
	<p>Delay Profile (Zoom): Press this submenu key to enable this graph for marker configuration. This graph displays the portion of the signal that is highlighted in the Delay Profile (All) graph. The marker is a green diamond.</p>
	<p>The delay time of the marker position (in microseconds) based on maximum level, the distance (in meters) calculated from the delay time, and the relative (dB) level are displayed at the upper-right corner of the zoom graph.</p>
	<p>Frequency Response: Press this submenu key to enable marker configuration. The standard marker is a green diamond on the frequency response signal. The marker values, as displayed at the lower-right of the graph, are the relative frequency of the marker position (based on the center frequency of the channel) and the relative (dB) level of the marker position (based on the average level within the bandwidth). Selecting this submenu key adds the Delta Marker submenu key to the menu.</p>
	<p>Delta Marker On Off: This submenu key is displayed only when Frequency Response is the selected graph. Press this submenu key to toggle the Delta Marker On and Off. The delta marker appears initially at the same location as the standard marker (the 2 markers are superimposed).</p>
	<p>When the Delta Marker is On, the information at the lower-right corner of the graph is the relative difference between the signal components of the reference marker and the delta marker. These signal components are level, distance, and frequency. When the Delta Marker is Off, only the signal components of the standard marker are displayed.</p>
	<p>Back: Press this submenu key to return to the “Modulation Delay Profile Configuration Menu” on page 4-82.</p>

Figure 4-59. Marker Menu (Modulation Analysis Delay Profile)

4-36 Delay Profile Information Display (Custom)

Delay Profile is the selected measurement display format. The Marker function is Off.

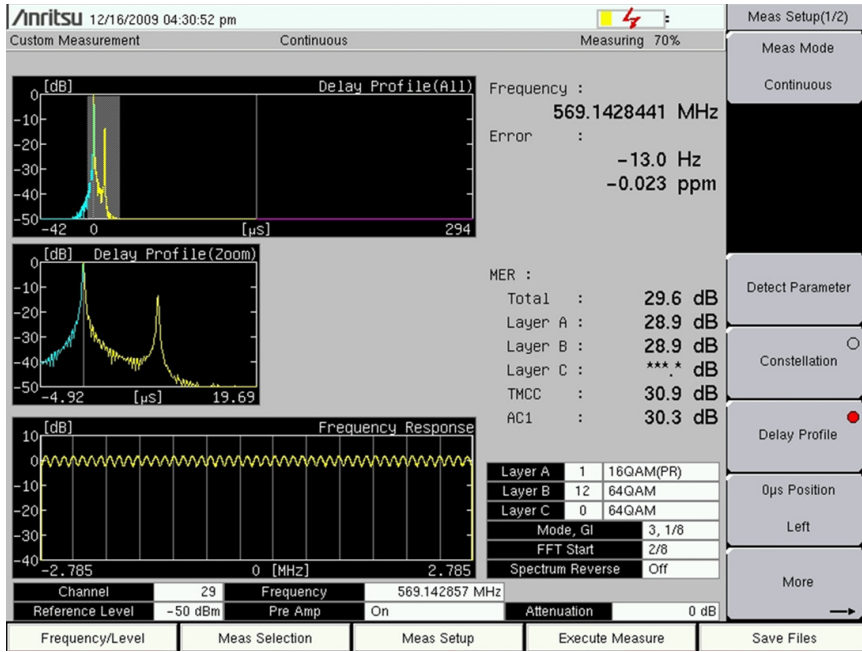


Figure 4-60. Modulation Analysis – Delay Profile Measurement Display

The Marker function is On, and the Marker menu shows that the Delay Profile (Zoom) graph is using the active marker.

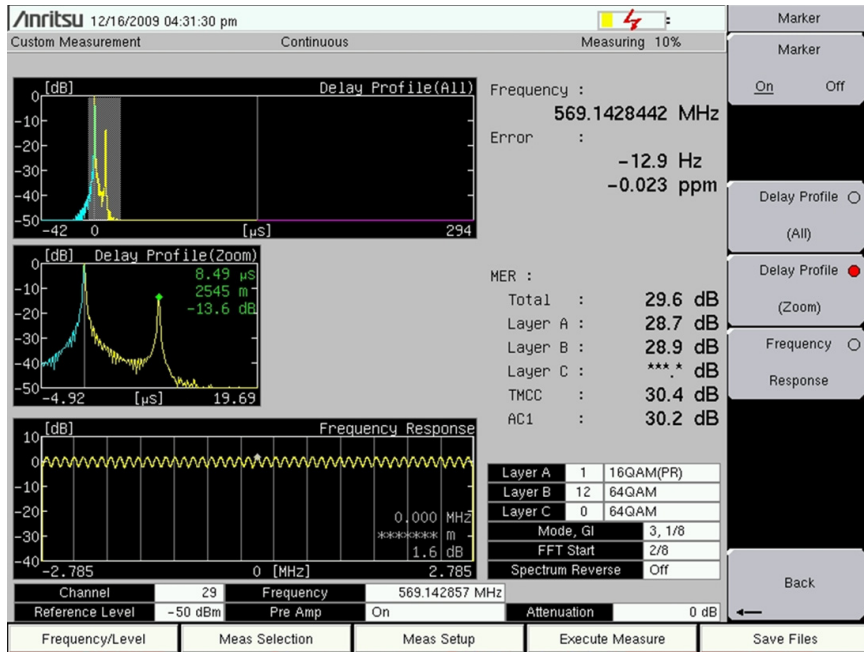


Figure 4-61. Marker Enabled in Delay Profile (Zoom) Graph

The Marker function is On, and the Marker menu shows that the Delay Profile (Zoom) graph is using the active marker.

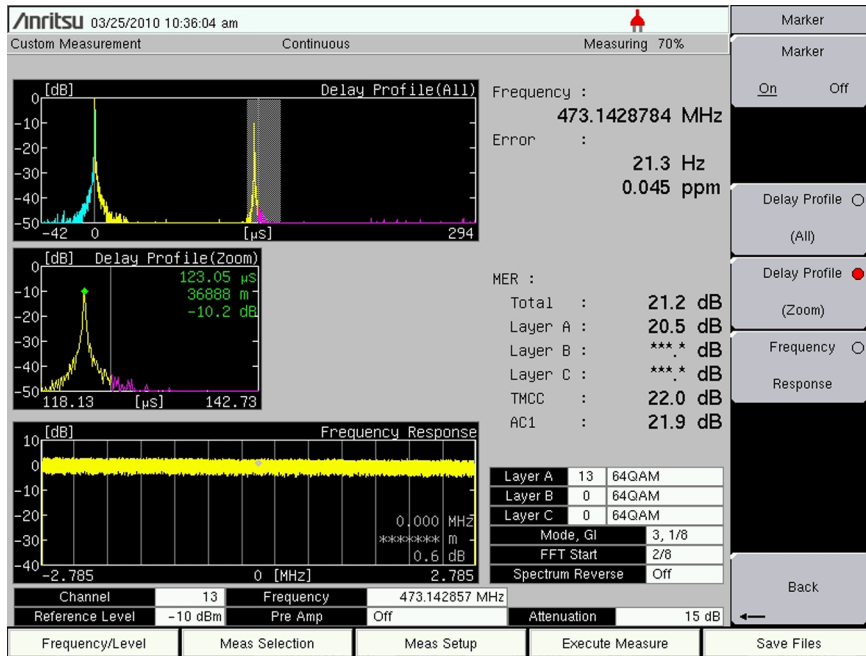


Figure 4-62. Marker Enabled in Delay Profile (Zoom) Graph

The blue range (visible in the Delay Profile (All) graph) shows signals that are delayed less than 0 μs if the largest signal (not necessarily the least delayed) is set at 0 μs . In both Delay Profile graphs, the yellow area shows delayed signals that are within the Guard Interval, and the magenta area shows signals that are delayed beyond the Guard Interval (which are potentially problematic). For more configuration details, refer to section “Delay Profile Configuration” on page 4-29.

Delay Profile (All) Graph, Marker Enabled

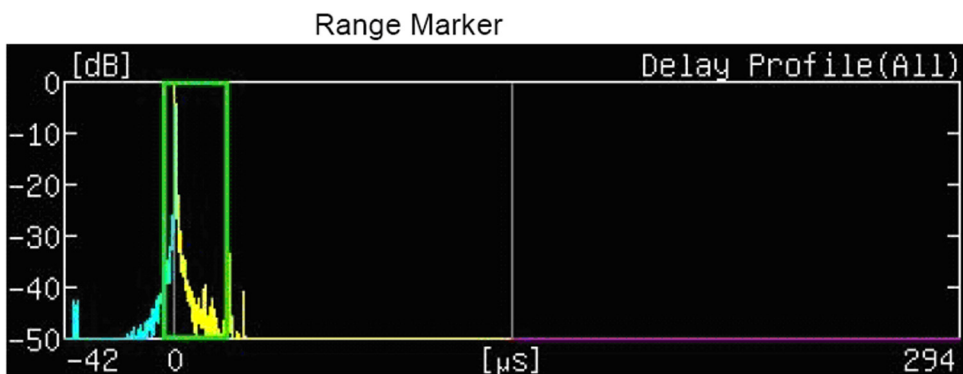


Figure 4-63. Entire (All) Graph of Delay Profile

Delay Profile (Zoom) Graph, Marker Enabled

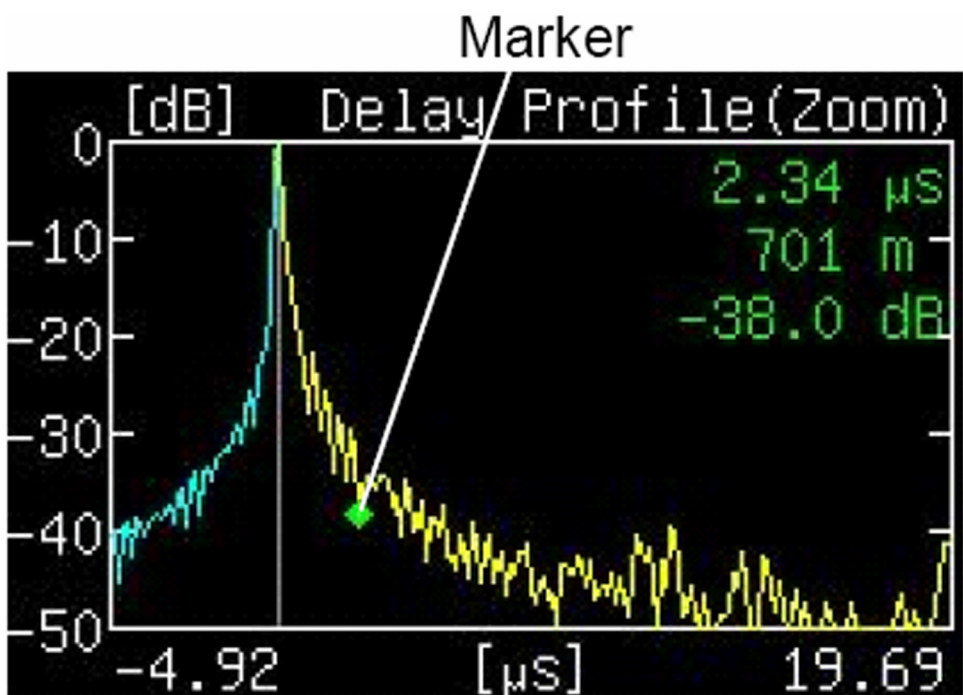


Figure 4-64. Enlarged (Zoom) Graph of Delay Profile

The formula to calculate the distance is as follows:

$$\text{Distance} = \text{Delay Time} \times \text{Velocity of Light (which is } 2.99792 \times 10^8 \text{ m/s)}$$

Delay Profile Frequency Response Graph, Marker Enabled

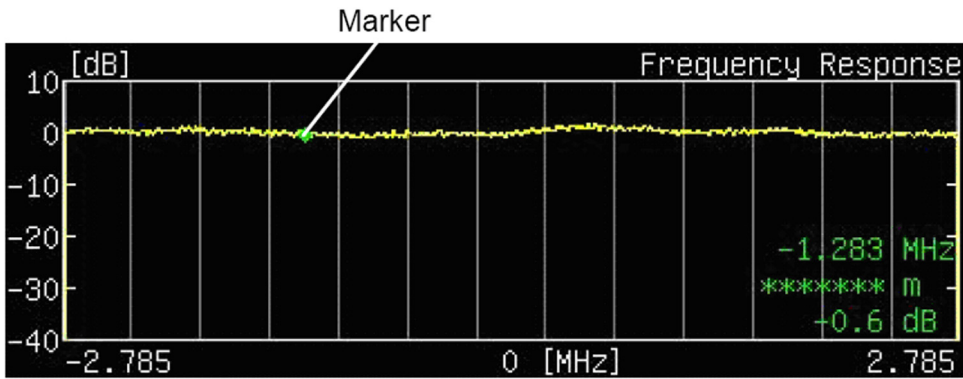


Figure 4-65. Frequency Response Graph with Standard Marker

Delay Profile Frequency Response Graph, Delta Marker Enabled

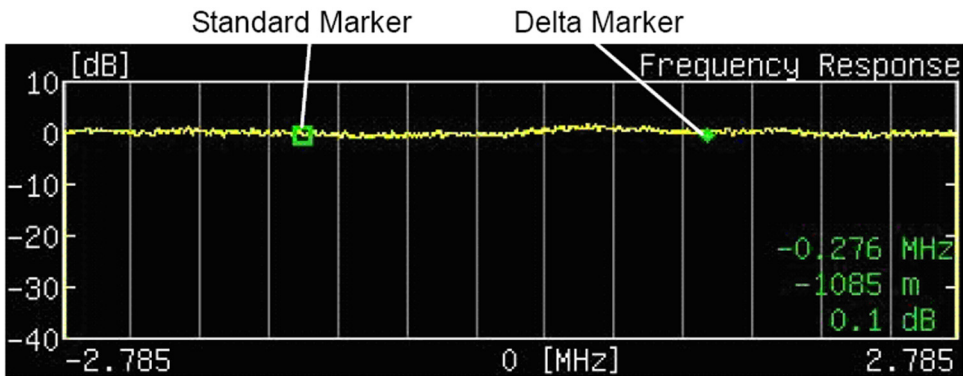


Figure 4-66. Frequency Response Graph with Delta Marker

4-37 Meas Setup Menu - Spectrum Mask Measurement

Custom

Key Sequence: **Meas Selection** > Spectrum Mask > **Meas Setup**

Meas Setup	<p>Mask Type: Press this submenu key to open the Select Mask Type list box. Choose from the 3 options: Critical Mask, Subcritical Mask, and Noncritical Mask. Refer to Section 4-13 “Spectrum Mask, Custom” on page 4-34.</p>
Mask Type	<p>Antenna Power: Press this submenu key to open the Antenna Power Editor dialog box and to display the Units menu. Use the arrow keys, the rotary knob, or the numeric keyboard to set the power. Press the W or mW submenu key, or press the Enter key. Pressing Enter is the same as pressing the W submenu key. The power range and available increments are displayed.</p>
Antenna Power	<p>This submenu key is displayed only when the selected Mask Type is Type B ($0.25W < P \leq 2.50W$) or Type B ($0.025W < P < 0.25W$) (only when UHF (Brazil) is not the Channel Map). Refer to Step 12 on page 4-40.</p>
Filter Selection	<p>Filter Selection: Press this submenu key to display open the Select Filter list box. Use the Default filter or select one of the three user-specified filters. Refer to Step 8 on page 4-38. This submenu key is displayed only when the Channel Map is UHF (Brazil).</p>
Filter Data On <u>Off</u>	<p>Filter Data On Off: Press this submenu key to toggle the setting On and Off. When On, the filter characteristics (normalized to -27.4 dB) are displayed in green. This is not part of the measurement. Refer to Step 9 on page 4-39. This submenu key is displayed only when the Channel Map is UHF (Brazil).</p>
Corrected Data On <u>Off</u>	<p>Corrected Data On Off: Press this submenu key to turn this feature On or Off. When On, the Corrected Data is displayed in yellow. This yellow measurement data is the measurement data after being corrected with the filter characteristics (the filter must first be applied). This submenu key is displayed only when the Channel Map is UHF (Brazil).</p>
UnCorrected Data On <u>Off</u>	<p>UnCorrected Data On Off: Press this submenu key to turn this feature On or Off. When On, the UnCorrected Data is displayed in gray. This represents the uncorrected measurement data before the filter correction has been applied. This submenu key is displayed only when the Channel Map is UHF (Brazil).</p>
Floor reduction On <u>Off</u>	<p>Floor reduction On Off: Press this submenu key to turn On or Off the floor reduction adjustment. Pressing this submenu key (to On or Off) triggers a measurement. Refer to Step 13 on page 4-41.</p>
Marker On <u>Off</u>	<p>Marker On Off: Press this submenu key to turn On or Off the marker feature. A green diamond marker is displayed on the measured signal. The values that are displayed in the upper-right corner of the graph are the relative frequency of the marker position (based on the graph center) and the relative level of the marker position (based on the 0 dB position of the graph).</p>

Figure 4-67. Measurement Setup Menu - Spectrum Mask Measurement (Custom)

For additional information about Spectrum Mask measurements, refer to [Section 4-13 “Spectrum Mask, Custom” on page 4-34](#). Type A and Type B masks are described in [Section 4-13](#) and in [Figure 4-22, “Type A Spectrum Mask” on page 4-43](#) and [Figure 4-20, “Type B Spectrum Mask” on page 4-41](#).

In the Easy Measurement mode, the Spectrum Mask Meas Setup menu has no available submenu keys. All measurement setup parameters are preset.

4-38 Meas Setup Menu - Phase Noise Measurement

Custom

Key Sequence: **Meas Selection** > Spectrum Mask > **Meas Setup**

Meas Setup	<p>Meas Mode: Press this submenu key to open the Select Meas Mode list box. Highlight a measurement mode and press the Enter key. Refer to Section 4-25 “Select Meas Mode List Box (Custom)” on page 4-74.</p>
Meas Mode Average	<p>Average Count: Press this submenu key to open the Average Count Editor edit box to set the Average Count. The setting is displayed on the submenu key. This submenu key is displayed only when Meas Mode is set to Average or to Moving Average.</p>
Average Count ##	<p>Marker</p>
	<p>On Off: Press this submenu key to toggle the Marker On and Off.</p>
Marker <u>On</u> Off	<p>When On, The Marker is a green diamond on the measurement waveform of the CW frequency/phase noise graph. Information in the upper-right corner of the Phase Noise graph includes:</p>
Integration <u>On</u> Off	<p>Relative frequency of the marker position based on level (Hz) Phase Noise (dBc/Hz) Signal-to-Marker ratio (dBc)</p>
	<p>Refer to “Phase Noise and Marker Function” on page 4-96.</p>
	<p>Integration</p>
	<p>On Off: This submenu key is displayed only when the Marker submenu key is set to On. Press the Integration submenu key to toggle On and Off the integration marker. When On, the range between the standard marker and the integration marker is displayed as a white band in the graph with the base at the point originally indicated by the standard marker. Change the marker range to left or right with the arrow keys or the rotary knob. The Up/Down arrow keys change the range approximately twice as much as the Left/Right arrow keys. The rotary knob changes the marker range in the smallest increments.</p>
	<p>The frequency range and the integration range that are displayed by the integration marker are shown in the upper-right corner of the graph.</p>
	<p>When turned Off, the standard marker is again displayed at its original position before using the integration marker.</p>
	<p>When the standard marker is On, you can also press the rotary knob or the Enter key to toggle the integration marker On and Off.</p>
	<p>Refer to “Phase Noise and Marker Function” on page 4-96.</p>

Figure 4-68. Measurement Setup Menu - Phase Noise Measurement (Custom)

In the Easy Measurement mode, the Phase Noise Meas Setup menu has no available submenu keys. All measurement setup parameters are preset.

Phase Noise and Marker Function

When using the standard marker, the phase noise is displayed in the graph in units of dBc/Hz.

Level arithmetic processing to convert to the 1-Hz bandwidth is performed on the assumption that the noise component level is fixed in the measurement of CW frequency and phase noise. Because the spurious component signal is calculated in the same way, the value cannot be correct. Signal-to-Marker ratio (in dBc) is therefore shown separately from phase noise (in dBc/Hz) as the measurement result for the spurious component.

4-39 Meas Setup Menu - Spurious Emissions

Custom and Easy

Key Sequence: **Meas Selection** > Spurious Emissions > **Meas Setup**

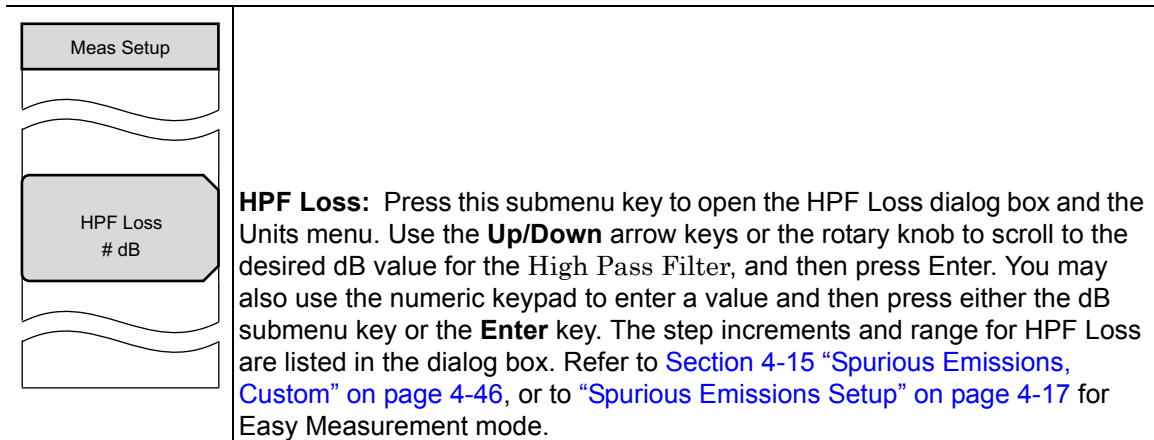


Figure 4-69. Measurement Setup Menu - Spurious Emissions Measurement (Custom and Easy)

4-40 Meas Setup Menu - BER

Custom

Key Sequence: **Meas Selection** > BER > **Meas Setup**

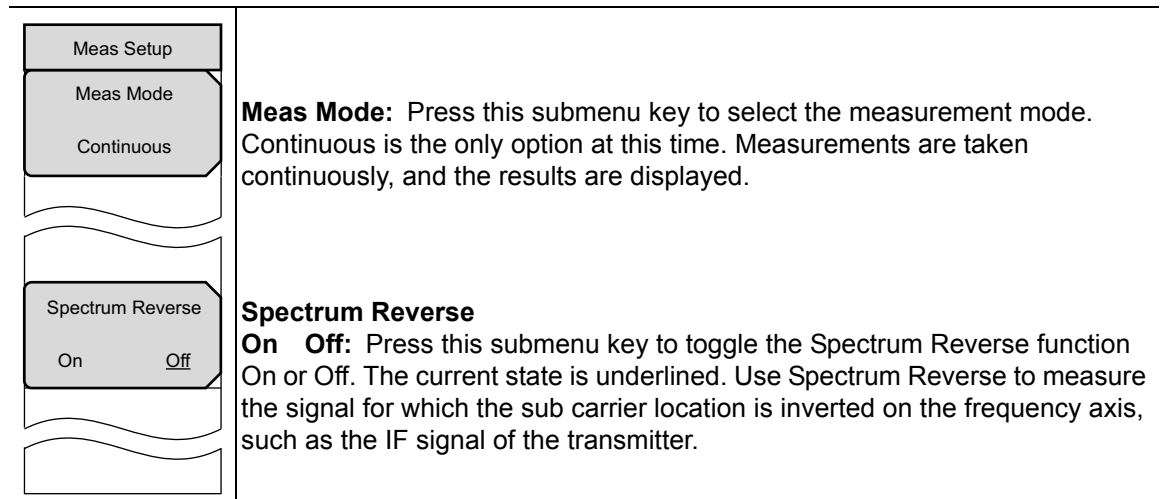


Figure 4-70. Meas Setup Menu - BER

4-41 Meas Setup Menu - Spectrum Monitor

Custom

Key Sequence: **Meas Selection** > Spectrum Monitor > **Meas Setup**

Meas Setup	<p>For additional details, refer to Section 4-17 "Spectrum Monitor, Custom" on page 4-49.</p> <p>Meas Mode: Press this submenu key to open the Select Meas Mode list box. Use the Up/Down arrow keys or the rotary knob to highlight the desired measurement mode and then press Enter. Choose from: Single and Continuous. For a description of these modes, refer to Section 4-25 "Select Meas Mode List Box (Custom)" on page 4-74.</p> <p>Span: Press this submenu key to open the Select Span list box and select the number of channels to display on the measurement screen (graph). Use the Up/Down arrow keys or the rotary knob to highlight the desired number of channels to span, and then press Enter. Refer to Table 4-15 on page 4-49 for the RBW, VBW, and Detection parameters for each Span setting. The values that are shown in this table are set internally and are not displayed on the instrument screen.</p> <p>Six span options are available: 1 CH, 3 CH, 5 CH, 11 CH, 31 CH, and 51 CH.</p> <p>The Span setting can be incremented (stepping through the six settings that are available in the Select Span list box) by pressing the Up/Down arrow keys.</p> <p>Zone Position to Center: Press this submenu key to move the currently marked channel (the channel that is within the green zone markers) to the center of the measurement display (the center of the sweep window). This also executes a measurement.</p> <p>Scrolling with the rotary knob moves the green zone markers to adjacent channels. The channel number, frequency, and power level are displayed in green in the upper-right corner of the graph for the channel that is within the green zone markers.</p> <p>Note: A blue diamond-shaped marker (within the green zone markers) indicates frequency and level information of the peak value within the channel. The data is displayed in blue in the upper-right corner of the graph. This is an automatic function that has no user controls.</p>
Meas Mode Continuous	
Span #CH	
Zone Position to Center	

Figure 4-71. Measurement Setup Menu - Spectrum Monitor Measurement (Custom)

In the Easy Measurement mode, the Spectrum Monitor Meas Setup menu has no available submenu keys. All measurement setup parameters are preset.

Chapter 5 — ISDB-T SFN Analyzer

(Option 32)

5-1 Introduction

This chapter provides a description of ISDB-T Single Frequency Network (SFN) setup and measurement for signal power and signal analysis with Option 32 on the instrument. Note that Option 9 (IQ Demodulation Hardware) may be required in your instrument in order to use Option 32. You can measure channel power along with the field strength and power of each incoming signal even when there are several incoming multi-path signals. The measurement time for delay profile measurements is longer to allow for the measurement of signals coming from distant sites in the network.

Field Strength Measurements in SFN Environments include Level, Delay, and DU Ratio of each incoming signal along with the time delay between signals.

The main menu keys in this instrument mode are:

Frequency/Level Blank (Unused) Meas Setup Execute Measure Save Files

Screen images of measurements, as shown in this document, are examples. The images on your instrument may differ in appearance.

5-2 Instrument Connections

Attach the antenna to the connector labeled Spectrum Analyzer RF In on top of your instrument. [Figure 1-1 on page 1-3](#) is an example of an Anritsu handheld instrument. Refer to your User Guide for a description of the connectors on your instrument.

5-3 Digital Television Signal Analyzer Technology

Carrier modes, OFDM carriers, Guard Intervals, the FFT Start position, and other ISDB-T functions are described in [Section 1-6 “Digital Television Signal Analyzer Technology” on page 1-4](#) and [Section 4-5 “ISDB-T Signal Analyzer Technology” on page 4-4](#).

5-4 Antenna Setup

The antenna attaches to the instrument with a coaxial cable. The antenna and coaxial cable are not supplied with the instrument and are to be obtained separately. The antenna factors are different for each antenna. Refer to the documentation for your antenna. Then select an antenna from the standard list that is available on the instrument. If your antenna is not on the list, then use the Antenna Editor function of Master Software Tools to define a custom antenna and to upload the antenna information into the antenna list on the instrument. You can use Master Software Tools (MST) to update your antenna and coaxial cable lists. For directions about updating these lists, refer to the Master Software Tools documentation (available from www.anritsu.com).

Antenna Setup Procedure:

1. Attach the antenna to the Spectrum Analyzer connector on top of the instrument (refer to your instrument User Guide for connector identification).

Antenna Selection:

2. Press the **Meas Setup** main menu key to open the “[Meas Setup \(1/2\) Menu](#)” on page 5-16.
3. Press the Delay Profile submenu key and then press the **MORE** submenu key.
4. Press the Correction Value submenu key.
5. Press the Antenna (Correction Level) submenu key. The Select Antenna list is displayed.
6. Use the arrow keys or the rotary knob to scroll to the desired Anritsu antenna model number and then press **Enter**. Each press of an **Up/Down** arrow key moves the selection highlight up and down by one line. The **Left** and **Right** arrow keys move the selection highlight to the top and bottom (respectively) of the antenna list.
7. Press the **Back** submenu key twice to return to the “[Meas Setup \(1/2\) Menu](#)”.

5-5 Measurement Setup and Execution

Frequency and Reference Level Configurations

Set up the frequency and reference level parameters by using the following procedure:

1. Press the **Frequency/Level** main menu key. Configure the following parameters as needed: Channel Map, Frequency, Auto Reference Level, Reference Level, and Pre Amp.
2. Press the **Channel Map** submenu key. The Select Channel Map list is displayed. Select UHF, UHF (Brazil), or None and then press **Enter**.
 - a. If you have selected UHF or UHF (Brazil), then press the **Channel** submenu key, scroll to the desired channel, and press **Enter**. The selected channel number is displayed on the face of the **Channel** submenu key.
 - b. If you have selected None, then enter the center frequency manually.
 - c. Press the **Frequency** submenu key to open the Frequency Editor dialog. The Units menu is also displayed.

The Units menu displays four unit submenu keys: GHz, MHz, kHz, and Hz. If any of these units are not appropriate, then pressing the key displays “Out of range” at the bottom of the Frequency Editor window. Set the frequency by using the **Up/Down** arrow keys, the rotary knob, or the number keys. When the desired range is displayed, press the appropriate unit submenu key, the rotary knob, or the **Enter** key. Pressing **Enter** is the same as pressing the MHz submenu key.

3. Press the **Auto Reference Level** submenu key to allow the instrument to set an optimum reference level, or press the **Reference Level** submenu key to open the Reference Level Editor dialog box. To manually set the dBm reference level, use the **Up/Down** arrow keys, the rotary knob, or the number keys, then press the rotary knob or the **Enter** key. After entering a value by using the number keys, press the **+/-** key to create a negative value.
4. Press the **Pre Amp** submenu key to toggle this function On or Off. The current setting is displayed on the submenu key.

5-6 Measurements

Set Up the Test

1. Press the **Meas Setup** main menu key to display the “**Meas Setup (1/2) Menu**”.
2. Press the Meas Mode submenu key to open the Select Meas Mode list, and then choose either Single or Continuous measurement.
3. Press the Detect Parameter submenu key to automatically detect for Mode, GI and TMCC Information from the input signal.

Delay Profile Measurement Setup

Press the Delay Profile submenu key to view the Delay Profile measurement screen. Press the More submenu key to display the “**Meas Setup (2/2) (Delay Profile) Menu**” and continue configuring the Delay Profile parameters.

1. Press the Mode, GI submenu key, then highlight the desired Mode, Guard Interval parameter in the Select Mode, GI list. Then press **Enter**.
2. Press the TMCC Information submenu key. The TMCC Information Editor dialog box and “**TMCC Information Menu**” are displayed.
 - a. Set up the Layer Segments. The total sum of segments among segments A, B, and C must add up to 13.
 - b. Press the desired Layer Segment submenu key to select layer segment Layer A, B, or C.
 - c. Use the **Up/Down** arrow keys or the rotary knob to change the segment number.
 - d. Press the desired Layer Modulation submenu key (Layer A, Layer B, or Layer C) to set up the Layer Modulations.
 - e. Press the Layer (A, B, or C) submenu key to scroll to the desired modulation: 64QAM, 16QAM, or QSPK.
 - f. Press the **Enter** key. The setup function returns to the “**Meas Setup (2/2) (Delay Profile) Menu**”.
3. Press the FFT Start submenu key to open the Select FFT Start list box, then select the desired start position with a guard interval (0/8 indicates no guard interval).
4. Press the Spectrum Reverse submenu key to toggle between On and Off. The active state is underlined.
5. Press the Correction Value submenu key to display the “**Correction Value Menu**”.
 - a. Press the Antenna (Correction Level) submenu key, highlight the desired Anritsu antenna model number, and then press **Enter**.
 - b. Press the Impedance submenu key and choose: 50 ohm, 75 ohm, or Other.
 - c. If you select Other, then the Impedance Loss submenu key is displayed in the Correction Value menu. Press the Impedance Loss submenu key to open the Impedance Loss Editor dialog box and enter a dB loss level within the displayed range.
 - d. Press the Back submenu key to return to the “**Meas Setup (2/2) (Delay Profile) Menu**”.

6. Press the Delay Profile Vertical Range submenu key to display the “Delay Profile Vertical Range Menu”. Press the desired vertical range (dB) value submenu key. The red dot on the submenu key denotes the selected vertical range. Then press the Back submenu key to return to the “Meas Setup (2/2) (Delay Profile) Menu”.
7. Press the Display Waveform submenu key to display the “Display Waveform Menu”. Press the appropriate submenu key to turn On or Off the following parameters:
 - a. Press the Last Result submenu key to toggle it to On in order to view the last waveform (yellow) result.
 - b. Press the Power Method submenu key to toggle it to On in order to display the delay path profile waveform (light blue) that is created by the power spectrum method.
 - c. Press the Transfer Method submenu key to toggle it to On in order to display the delay path profile waveform (magenta) that is created by the transfer function method.
 - d. Press the Back submenu key to return to the “Meas Setup (2/2) (Delay Profile) Menu”.
8. Press the Back submenu key to return to the “Meas Setup (1/2) Menu”.
9. Press the Marker submenu key to open the “Marker Menu (Delay Profile)”.
 - a. Press the Marker submenu key to toggle the function to Move or Fix the marker.
 - b. Press the Delay Profile submenu key to select and configure the marker in the Delay Profile (All) view or Delay Profile (Zoom) view.
 - c. If Delay Profile (Zoom) is selected, then press the Marker Mode submenu key to select either Normal or Zone.
 - d. Press the Detect MaxLevel submenu key.
 - e. Press the Main to Center of Zoom submenu key.
 - f. Press the Path to Center of Zoom submenu key.
 - g. Press the Back submenu key to return to the “Meas Setup (1/2) Menu”.

Inband Spectrum Measurement Setup

Press the Inband Spectrum submenu key to view the Inband Spectrum measurement screen. Press the More submenu key to display the “Meas Setup (2/2) (Inband Spectrum) Menu” Meas Setup (2/2) menu and continue configuring the Inband Spectrum parameters.

1. Press the Mode, GI submenu key. Highlight the desired Mode, Guard Interval parameter in the Select Mode, GI list, and then press **Enter**.
2. Press the TMCC Information submenu key. The TMCC Information Editor dialog box and TMCC Information menu are displayed.
 - a. Set up the Layer segment. The total sum of segments among segments A, B, and C must add up to 13.
 - b. Press the desired Layer segment submenu key to select the desired layer segment A, B, or C.
 - c. Use the **Up/Down** arrow keys or the rotary knob to change the segment number.

- d. Set up the Layer Modulation.
 - e. Press the desired Layer Modulation submenu key.
 - f. Press the specific Layer Modulation submenu key to scroll to the desired modulation: 64QAM, 16QAM, or QSPK.
 - g. Press the **Enter** key. The setup returns to the “Meas Setup (2/2) (Inband Spectrum) Menu”.
3. Press the FFT Start submenu key to open the Select FFT Start list box, and then select the desired start position with a guard interval (0/8 indicates no guard interval).
4. Press the Spectrum Reverse submenu key to toggle between On and Off. The active state is underlined.
5. Press the Correction Value submenu key to display the “Correction Value Menu”.
 - a. Press the Antenna (Correction Level) submenu key, highlight the desired Anritsu antenna model number in the Select Antenna list, and then press **Enter**.
 - b. Press the Impedance submenu key to toggle among the choices: 50 ohm, 75 ohm, or Other.
 - c. If you select Other, then the Impedance Loss submenu key is displayed in the Correction Value menu. Press the Impedance Loss submenu key to open the Impedance Loss Editor dialog box and enter a dB loss level within the displayed range.
 - d. Press the Back submenu key to return to the “Meas Setup (2/2) (Inband Spectrum) Menu”.
6. Press the Inband Spectrum Vertical Range submenu key to display the “Inband Spectrum Vertical Range Menu”. Select a range (dB). The red dot on the submenu key denotes the selected vertical range. Press the Back submenu key to return to the “Meas Setup (2/2) (Inband Spectrum) Menu”.
7. Press the Back submenu key again to return to the “Meas Setup (1/2) Menu”.
8. Press the Marker submenu key to display the “Marker Menu (Inband Spectrum)” Marker menu (refer to Figure 5-9 on page 5-18). (Use the arrow keys or rotary knob to move the marker and delta marker.)
 - a. Press the Marker submenu key to toggle the marker on the graph On or Off.
 - b. Press the Delta Marker submenu key to toggle the delta marker On or Off.
 - c. Press the Back submenu key to return to the “Meas Setup (1/2) Menu”.

Execute the Test

Press the **Execute Measure** main menu key to begin testing. If the input signal cannot be measured, then a message is displayed with red highlighting near the top of the display area, as follows:

Under Level : Increase input level

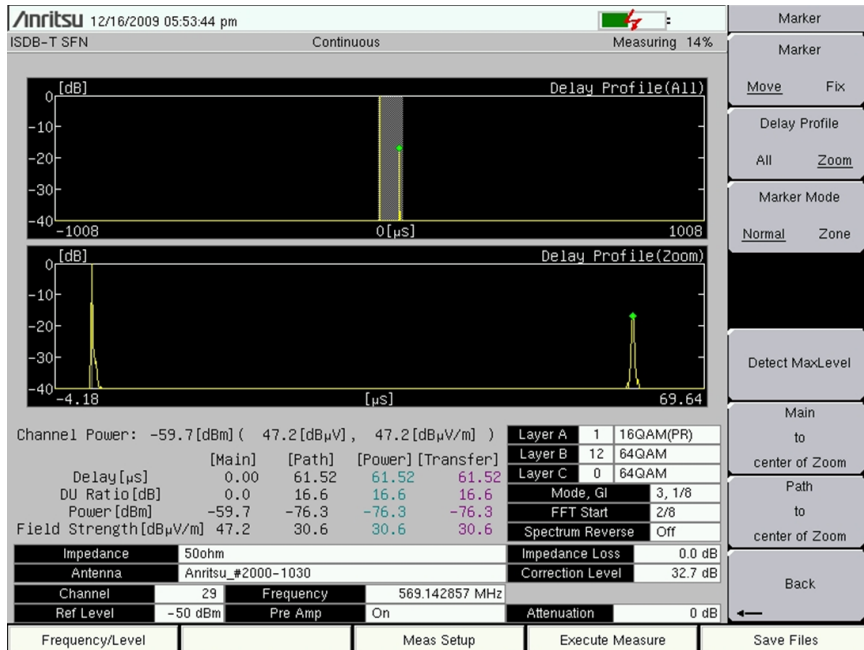


Figure 5-1. SFN Delay Profile Measurement

Save the Test Results

Press the **Save Files** main menu key to save a measurement. A confirmation window opens briefly to indicate that the measurement has been saved.

5-7 Saving Measurement Results

Measurement files are stored automatically or manually. Pressing the **Save Files** main menu key creates a title for the measurement file and stores the file into the instrument memory. Manually saving a file requires multiple steps for naming the file before storing into the instrument memory.

Automatic File Saving

Files are saved in the JPEG format and the CSV format. The filename format uses a string of 3 characters followed by a string of digits for the date and time. The entire character string appears as follows:

Delay Profile

SFPYYYYMMDD_HHMMSS.csv

SFPYYYYMMDD_HHMMSS.jpg

Inband Spectrum

SFSYYYYMMDD_HHMMSS.csv

SFSYYYYMMDD_HHMMSS.jpg

The date is expressed as year (YYYY), month (MM), and day (DD) followed by an underscore, and then the time is expressed as hour (HH), minute (MM), and second (SS), all followed by a period and then the file extension (CSV or JPG).

Manual File Saving

To save a measurement manually, refer to your instrument User Guide.

5-8 ISDB-T SFN Menus

In ISDB-T SFN Analyzer mode (Option 32), the instrument displays the following four main menu key menus: **Frequency/Level**, **Meas Setup**, **Execute Measure**, and **Save Files**.

In some Anritsu manuals, **main menu keys** may also be called **hard keys**, and submenu keys may also be called soft keys.

Frequency/Level Menus

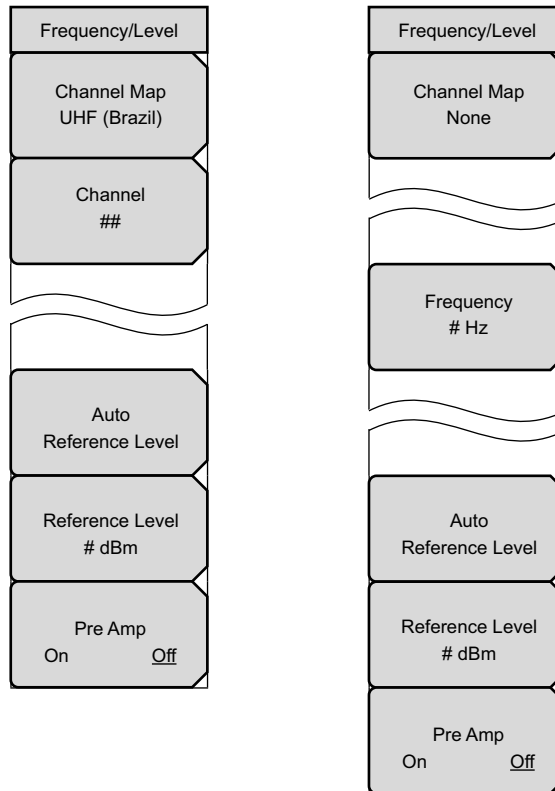


Figure 5-2. Frequency/Level Menus

Measurement Setup Menus

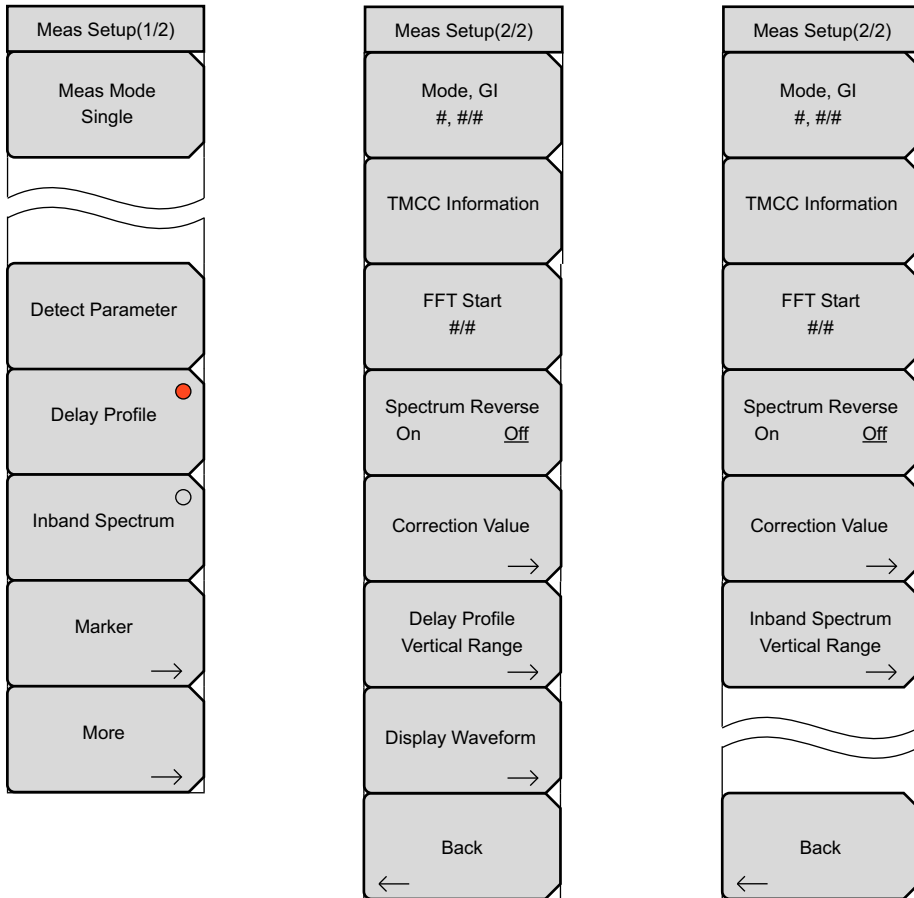


Figure 5-3. Measurement Setup Menus

Measurement Menus Group

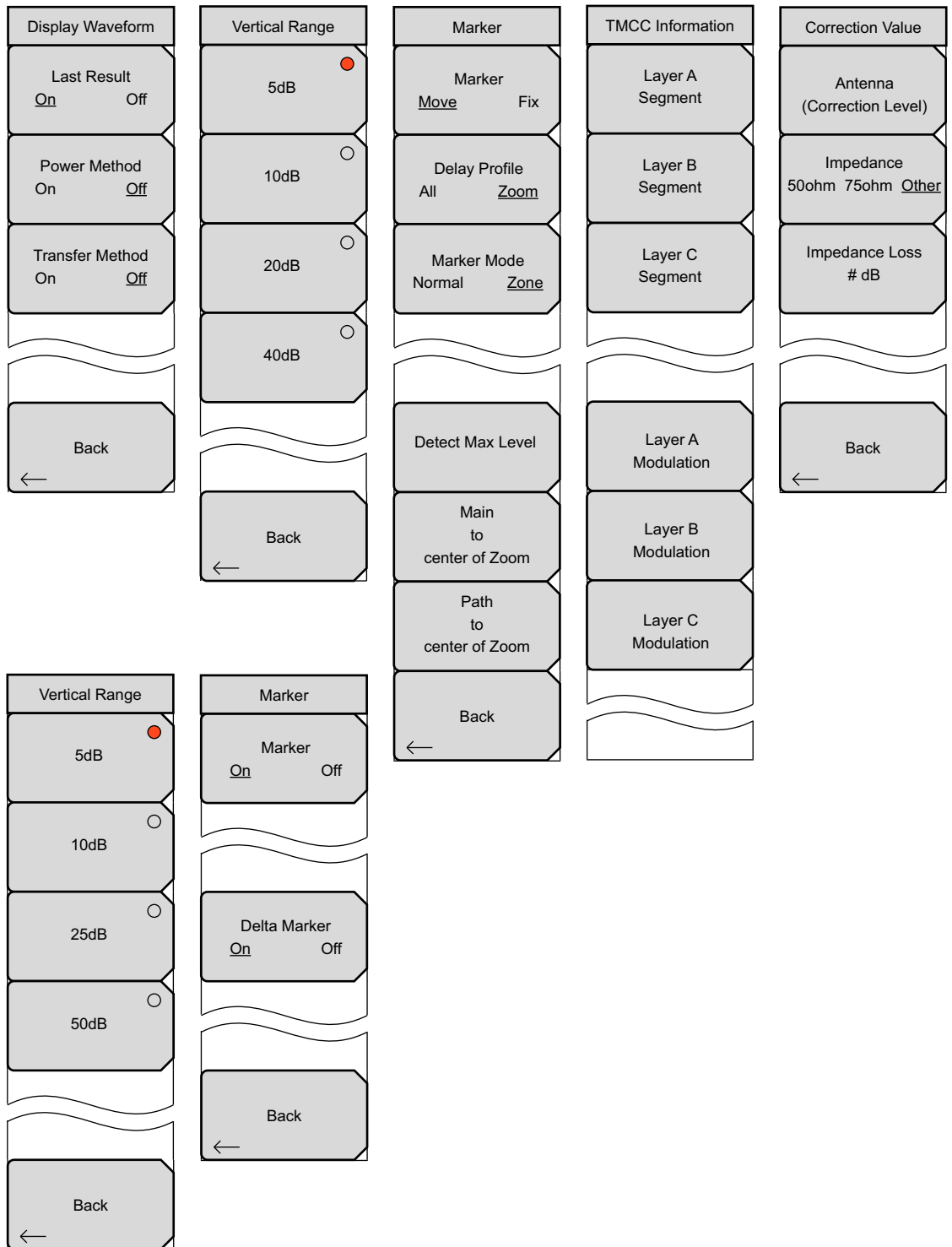


Figure 5-4. Measurement Menus for Delay Profile and Inband Spectrum

5-9 Frequency/Level Menu (Channel Map = UHF)

Key Sequence: **Frequency/Level**

This menu is displayed when Channel Map is set to UHF.

Frequency/Level	Channel Map: Press this submenu key to open the Channel Map list box. Choose from UHF, UHF (Brazil), or None.
Channel Map UHF (Brazil)	If UHF or UHF (Brazil) is selected, then the Channel submenu key is also displayed. If None is selected, then the Channel submenu key is not displayed, but the Frequency submenu key is also displayed.
Channel ##	Channel: If UHF is selected, then this submenu key is displayed. Press this submenu key to open the Channel Editor dialog box to select a UHF channel within the range of 13 to 62 that is displayed in the window. If UHF (Brazil) is chosen, then the channel range is 14 to 69.
Auto Reference Level	Frequency: If None is selected as the Channel Map parameter, then the Frequency submenu key is displayed in the menu. Press this submenu key to open the Frequency Editor dialog box to manually select a frequency within a specified range that is displayed in the window. The Units menu displays the following units: GHz, MHz, kHz, and Hz.
Reference Level # dBm	Auto Reference Level: Press this submenu key to automatically set the reference level to an optimum value. This reference level indicates the signal level that is being measured by the instrument. For more information, refer to section “Auto Reference Level” on page 5-14 .
Pre Amp On <u>Off</u>	Reference Level: Press this submenu key to open the Reference Level Editor dialog box and set a signal reference value within the specified range that is displayed in the window. If the Pre Amp submenu key is On, then the reference level range is from –10 dBm to –50 dBm in 10 dB increments. If the Pre Amp submenu key is Off, then the reference level range is from –25 dBm to +20 dBm in 5 dB increments.
	Pre Amp On Off: Press this submenu key to toggle the Pre Amp On and Off. The current state is underlined on the submenu key. When the preamplifier is switched On, the reference level is automatically set to –30 dBm. When the preamplifier is switched Off, the reference level is automatically set to –25 dBm. Refer to Table 5-1 on page 5-15 for the relationship between Reference Level and Input Attenuator.
	Warning: The upper limit level, up to which the instrument is not damaged, depends on the preamplifier state. Refer to the Warning message on page 5-14 .

Figure 5-5. Frequency Menu

5-10 Frequency/Level Menu (Channel Map = None)

Key Sequence: **Frequency/Level**

This menu is displayed when Channel Map is set to None.

Frequency/Level	<p>Channel Map: Press this submenu key to open the Channel Map list box. Choose from UHF, UHF (Brazil), or None.</p>
Channel Map None	<p>If UHF or UHF (Brazil) is selected, then the Channel submenu key is also displayed. If None is selected, then the Channel submenu key is not displayed, but the Frequency submenu key is also displayed.</p>
Frequency # Hz	<p>Channel: If UHF is selected, then this submenu key is displayed. Press this submenu key to open the Channel Editor dialog box to select a UHF channel within the range of 13 to 62 that is displayed in the window. If UHF (Brazil) is chosen, then the channel range is 14 to 69.</p>
Auto Reference Level	<p>Frequency: If None is selected as the Channel Map parameter, then the Frequency submenu key is displayed in the menu. Press this submenu key to open the Frequency Editor dialog box to manually select a frequency within a specified range that is displayed in the window. The Units menu displays the following units: GHz, MHz, kHz, and Hz.</p>
Reference Level # dBm	<p>Auto Reference Level: Press this submenu key to automatically set the reference level to an optimum value. This reference level indicates the signal level that is being measured by the instrument. For more information, refer to section “Auto Reference Level” on page 5-14.</p>
Pre Amp On <u>Off</u>	<p>Reference Level: Press this submenu key to open the Reference Level Editor dialog box and set a signal reference value within the specified range that is displayed in the window. If the Pre Amp submenu key is On, then the reference level range is from –10 dBm to –50 dBm in 10 dB increments. If the Pre Amp submenu key is Off, then the reference level range is from –25 dBm to +20 dBm in 5 dB increments.</p>
	<p>Pre Amp On Off: Press this submenu key to toggle the Pre Amp On and Off. The current state is underlined on the submenu key. When the preamplifier is switched On, the reference level is automatically set to –30 dBm. When the preamplifier is switched Off, the reference level is automatically set to –25 dBm. Refer to Table 5-1 on page 5-15 for the relationship between Reference Level and Input Attenuator.</p>
	<p>Warning: The upper limit level, up to which the instrument is not damaged, depends on the preamplifier state. Refer to the Warning message on page 5-14.</p>

Figure 5-6. Frequency Menu

The upper limit level, up to which the instrument is not damaged, depends on the preamplifier state.

Preamplifier On: –10 dBm

Warning Preamplifier Off: +20 dBm

Switching the preamplifier On, while applying greater than –10 dBm with preamplifier Off, may damage the internal electronic circuit. Pay attention to the input level when switching the preamplifier On or Off while applying a signal.

Auto Reference Level

The reference level range for input to the instrument is determined by the reference level setting. Immediately after a signal is applied to the instrument, the input attenuator is automatically set according to the reference level. The relationship between the reference level and the input attenuator is fixed. [Table 5-1 on page 5-15](#) shows the relationship between the reference level and the input attenuator for each measurement item. Raising the reference level increases attenuation of the input attenuator, enabling the user to handle a high input level. Note that the noise floor rises in proportion to the attenuation of the input attenuator.

When applying a signal to the instrument, provide a signal level that does not exceed the reference level value. If the signal level exceeds the reference level, then raise the reference level. For example, if the signal level is 0.5 dBm with preamplifier off, then set the reference level to 5 dBm, not to 0 dBm.

If an interfering wave other than the intended signal exists, and if the power within the frequency range of approximately 100 kHz to 7.1 GHz is 15 dB or more higher than the measurement signal level, then set the reference level to take the large signal into account.

Pre Amp, Reference Level, and Input Attenuator

Table 5-1. Relationship between Reference Level and Input Attenuator

Preamplifier	Reference Level (dBm)	Input Attenuator (dB)
Off	20	45
Off	15	40
Off	10	35
Off	5	30
Off	0	25
Off	-5	20
Off	-10	15
Off	-15	10
Off	-20	5
Off	-25	0
On	-10	40
On	-20	30
On	-30	20
On	-40	10
On	-50	0

5-11 Meas Setup (1/2) Menu

Key Sequence: **Meas Setup**

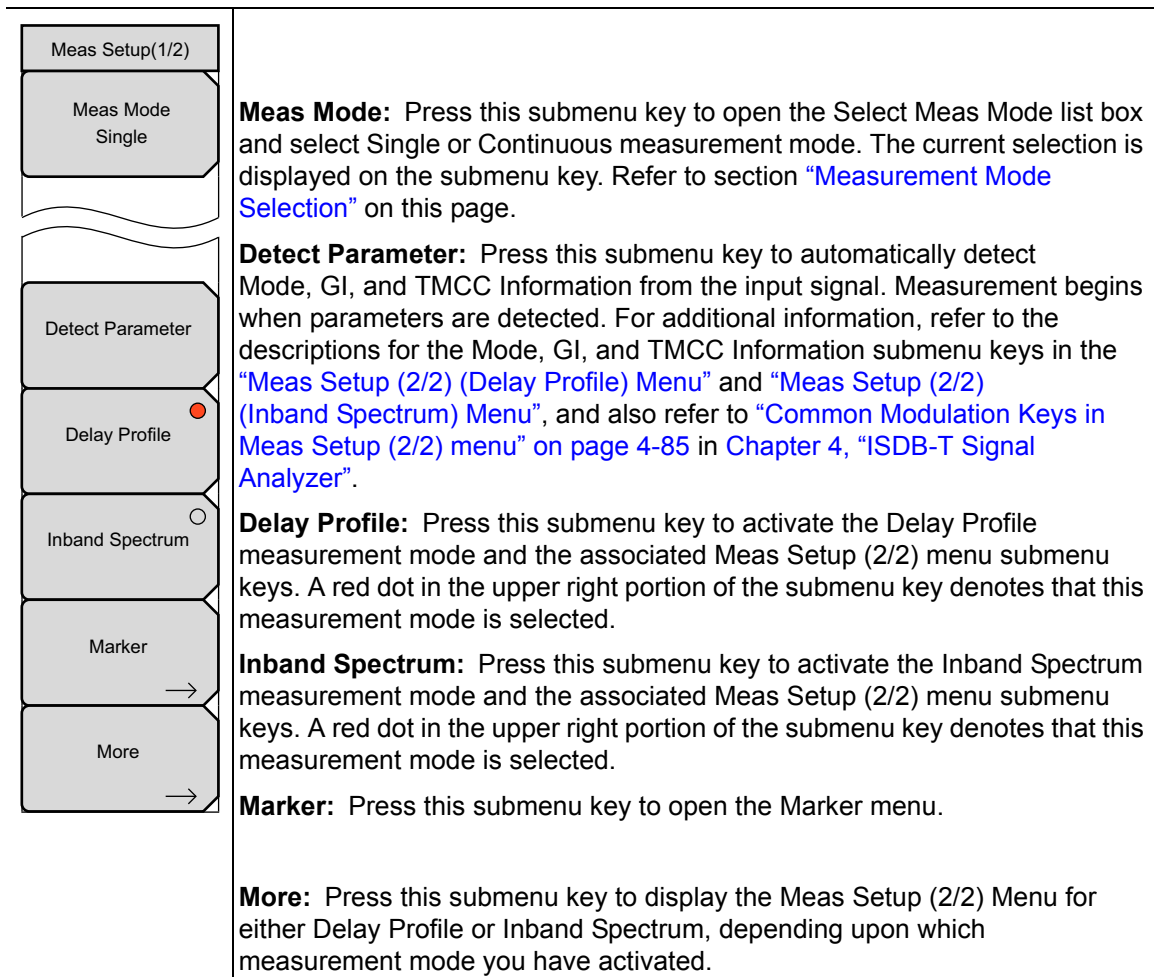


Figure 5-7. Meas Setup (1/2) Menu

Measurement Mode Selection

Single measurement mode sets up the test for one measurement. A measurement is taken, and the results are displayed on the screen. This mode is useful for capturing screen images.

Continuous measurement mode sets up the test to take measurements continuously and to display the results. This mode is helpful for real-time signal analysis.

5-12 Marker Menu (Delay Profile)

Key Sequence: **Meas Setup** > Delay Profile > Marker


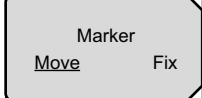
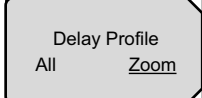
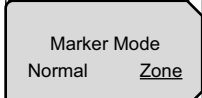

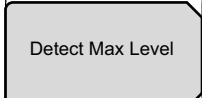
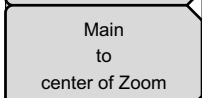
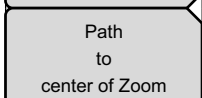

	<p>Marker Move Fix: Press this submenu key to toggle between Fix and Move.</p>
	<p>Selecting Fix locks in place the markers of Delay Profile (All) and Delay Profile (Zoom). For this reason, the Delay Profile, Marker Mode, Detect Max Level, Main to center of Zoom, and Path to center of Zoom submenu keys are not displayed.</p>
	<p>Selecting Move displays the other submenu keys for further marker setup: Delay Profile, Detect Max Level, Main to center of Zoom, and Path to center of Zoom.</p>
	<p>Delay Profile All Zoom: Press this submenu key to toggle the setting between All and Zoom. When set to All, the marker is displayed within the enlarged window on the Delay Profile (All) graph. The enlarged window presents the displayed range of the enlarged Delay Profile (Zoom) graph. Selecting Zoom adds the Marker Mode submenu key to the Marker menu.</p>
	
	<p>Delay Profile (All) detects the maximum level of the last result within the enlarged window and adjusts the marker to the maximum level.</p>
	<p>Delay Profile (Zoom) with Marker Mode set to Normal detects the maximum level of the last result within the All graph and adjusts the marker to the maximum level.</p>
	<p>Delay Profile (Zoom) with Marker Mode set to Zoom detects the maximum level of the last result within the All graph and adjusts the zone marker to the maximum level, so that the detection position of the maximum level is located at the center. When the maximum level is located at either edge of the All graph, the marker frame is automatically resized in the graph.</p>
	<p>Marker Mode Normal Zone: This submenu key is displayed only when the Delay Profile is set to Zoom. Press this submenu key to toggle the setting between Normal and Zone.</p>
<p>Toggleing to Zone turns on the Zone Marker in the Delay Profile (Zoom) graph.</p>	
<p>Detect Max Level: Press this submenu key to detect the various maximum levels of the Delay Profile (All) and Delay Profile (Zoom) graphs.</p>	
<p>Main to center of Zoom: Press this submenu key to move the enlarged window of the All graph so that the main wave (delay time of 0 μs) can be displayed, focusing around the enlarged graph.</p>	
<p>Path to center of Zoom: Press this submenu key to move the enlarged window so that the current marker position can be displayed, focusing around the enlarged graph.</p>	
<p>Back: Press this submenu key to return to the “Meas Setup (1/2) Menu” on page 5-16.</p>	

Figure 5-8. Marker Menu (Delay Profile)

5-13 Marker Menu (Inband Spectrum)

Key Sequence: **Meas Setup** > Inband Spectrum > Marker

<p>Marker</p>	<p>Marker On Off: Press this submenu key to toggle the Marker On and Off. The current setting is underlined. When On is selected, the diamond shaped marker is displayed. The marker frequency, distance, and level are displayed in green at the lower-right corner of the graph.</p>
<p>Marker <u>On</u> Off</p>	
<p>Delta Marker <u>On</u> Off</p>	<p>Delta Marker On Off: Press this submenu key to toggle the Delta Marker On and Off. The current setting is underlined. When On is selected, both the Standard Marker (square) and Delta Marker (diamond) are displayed on the graph. Delta Marker data for frequency, distance, and level are in reference to the standard marker position.</p>
<p>Back ←</p>	<p>Back: Press this submenu key to return to the “Meas Setup (1/2) Menu” on page 5-16.</p>

Figure 5-9. Marker Menu (Inband Spectrum)

5-14 Meas Setup (2/2) (Delay Profile) Menu

Key Sequence: **Meas Setup** > Delay Profile > More

Meas Setup(2/2)	Mode GI: Press this submenu key to open the Select Mode, GI list box. Scroll through the list to select the Mode (number of subcarriers) and the size of the Guard Interval. Table 5-2, “Mode and Guard Interval” on page 5-20 shows the relationship between Mode and guard Interval. For more information about Mode or Guard Interval, refer to Section 4-5 “ISDB-T Signal Analyzer Technology” on page 4-4 .
Mode, GI #, ##	
TMCC Information	TMCC Information: Press this submenu key to open the TMCC Information menu and the TMCC Information Editor dialog box.
FFT Start ###	FFT Start: Press this submenu key to open the Select FFT Start list box. Scroll to select an FFT Start position to synchronize with the data that is used for measurement. A setting of 0/8 uses none of the guard interval and includes only the effective symbol (the data portion of the OFDM frame). A setting of 1/8 adjusts the FFT Start position to use 1/8 of the guard interval, and a setting of 8/8 adjusts the FFT Start position to use all of the guard interval. Refer to Table 5-3, “Guard Interval Lengths in Microseconds” on page 5-20 .
Spectrum Reverse On <u>Off</u>	For a picture of the relationship between the FFT Start position and the guard intervals, refer to Figure 1-3 on page 1-8 . Signals that arrive with or without interference can be synchronized and measured by adjusting the FFT Start position. When measuring a delayed wave (a signal that is mixed with one or more earlier, but weaker, signals), changing the FFT Start position can filter interference.
Correction Value →	Spectrum Reverse On Off: Press this submenu key to toggle Spectrum Reverse On or Off. The current state is underlined. Use this function to measure a signal with its subcarrier position inverted on the frequency axis, such as a transmitter or medium frequency signal (IF signal) of a relay station.
Delay Profile Vertical Range →	Correction Value: Press this submenu key to display the “Correction Value Menu” on page 5-23 .
Display Waveform →	Delay Profile Vertical Range: Press this submenu key to open the “Delay Profile Vertical Range Menu” . Press the desired submenu key to set the y-axis scale for both Delay Profile graphs.
Back ←	Display Waveform: Press this submenu key to open the “Display Waveform Menu” . Back: Press this submenu key to return to the “Meas Setup (1/2) Menu” on page 5-16 .

Figure 5-10. Meas Setup (2/2) (Delay Profile) Menu

Mode, GI Relationship

Table 5-2. Mode and Guard Interval

Mode	Guard Interval
2	1/4
2	1/8
3	1/4
3	1/8
3	1/16

Guard Interval Lengths

Table 5-3. Guard Interval Lengths in Microseconds

Length	Mode 2	Mode 3
1/4	126 μ s	252 μ s
1/8	63 μ s	126 μ s
1/16	Not Supported	63 μ s

5-15 Meas Setup (2/2) (Inband Spectrum) Menu

Key Sequence: **Meas Setup** > Inband Spectrum > More

Meas Setup(2/2)	<p>Mode GI: Press this submenu key to open the Select Mode, GI list box. Scroll through the list to select the Mode (number of subcarriers) and the Guard Interval. Table 5-2, “Mode and Guard Interval” on page 5-20 shows the relationship between Mode and guard Interval. For more information about Mode or Guard Interval, refer to Section 4-5 “ISDB-T Signal Analyzer Technology” on page 4-4.</p>
Mode, GI #, ##	
TMCC Information	<p>TMCC Information: Press this submenu key to open the TMCC Information menu and the TMCC Information Editor dialog box.</p>
FFT Start ###	<p>FFT Start: Press this submenu key to open the Select FFT Start list box. Scroll to select an FFT Start position to synchronize with the data that is used for measurement. A setting of 0/8 uses none of the guard interval and includes only the effective symbol (the data portion of the OFDM frame). A setting of 1/8 adjusts the FFT Start position to use 1/8 of the guard interval, and a setting of 8/8 adjusts the FFT Start position to use all of the guard interval. Refer to Table 5-3, “Guard Interval Lengths in Microseconds” on page 5-20.</p>
Spectrum Reverse On <u>Off</u>	
Correction Value →	<p>For a picture of the relationship between the FFT Start position and the guard intervals, refer to Figure 1-3 on page 1-8. Signals that arrive with or without interference can be synchronized and measured by adjusting the FFT Start position. When measuring a delayed wave (a signal that is mixed with one or more earlier, but weaker, signals), changing the FFT Start position can filter interference.</p>
Inband Spectrum Vertical Range →	
Back ←	<p>Spectrum Reverse On Off: Press this submenu key to toggle Spectrum Reverse On or Off. The current state is underlined. Use this function to measure a signal with its subcarrier position inverted on the frequency axis, such as a transmitter or medium frequency signal (IF signal) of a relay station.</p> <p>Correction Value: Press this submenu key to display the “Correction Value Menu”.</p> <p>Inband Spectrum Vertical Range: Press this submenu key to open the “Inband Spectrum Vertical Range Menu”.</p> <p>Back: Press this submenu key to return to the “Meas Setup (1/2) Menu” on page 5-16.</p>

Figure 5-11. Meas Setup (2/2) Inband Spectrum Menu

5-16 TMCC Information Menu

Key Sequence: **Meas Setup** > Delay Profile > More

or

Key Sequence: **Meas Setup** > Inband Spectrum > More

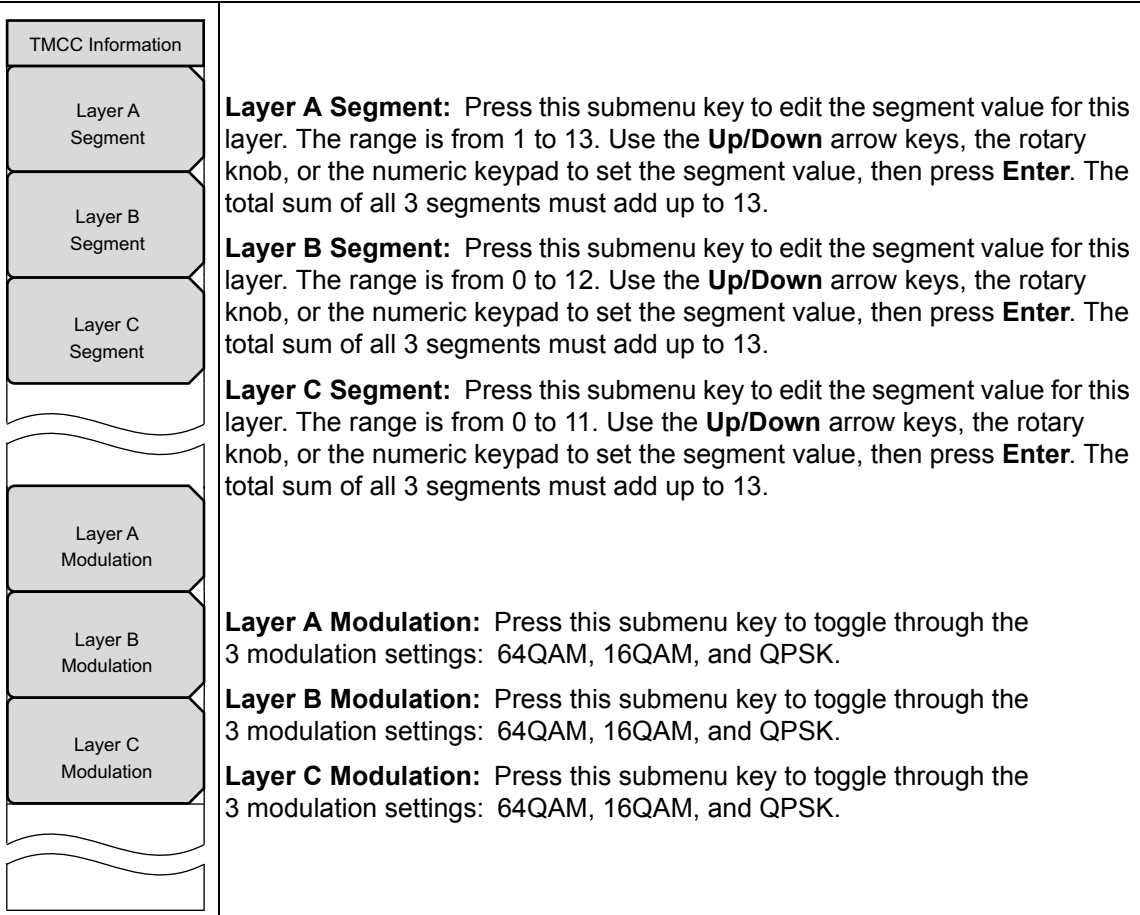


Figure 5-12. TMCC Information Menu

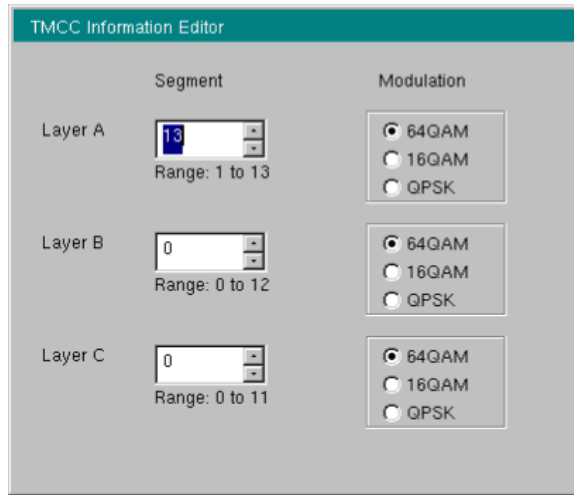


Figure 5-13. TMCC Information Editor Dialog Box

5-17 Correction Value Menu

Key Sequence: **Meas Setup** > Delay Profile > Correction Value

or

Key Sequence: **Meas Setup** > Inband Spectrum > Correction Value

<div style="border: 1px solid black; padding: 5px; margin-bottom: 5px;">Correction Value</div> <div style="border: 1px solid black; padding: 5px; margin-bottom: 5px;">Antenna (Correction Level)</div> <div style="border: 1px solid black; padding: 5px; margin-bottom: 5px;">Impedance 50ohm 75ohm <u>Other</u></div> <div style="border: 1px solid black; padding: 5px; margin-bottom: 5px;">Impedance Loss # dB</div> <div style="border: 1px solid black; padding: 5px; margin-bottom: 5px;">Back ←</div>	<p>Antenna (Correction Level): Press this submenu key to open the Select Antenna list box and select an antenna.</p> <p>Impedance 50ohm 75ohm Other: Press this submenu key to toggle through the 3 settings. The current setting is underlined.</p> <p>Select 50 ohms impedance when no converter is used. Impedance loss is automatically set to 0.0 dB.</p> <p>Select 75 ohms impedance when impedance converter 12N50-75B is used. Impedance loss is automatically set to 7.5 dB.</p> <p>Select Other impedance when an impedance converter other than the 12N50-75B is used. Selecting Other displays the Impedance Loss submenu key.</p> <p>Impedance Loss: This submenu key is displayed only when the Impedance submenu key is set to Other. Press this submenu key to open the Impedance Loss Editor dialog box and set a dB value.</p> <p>Set the impedance loss in the range of 0.0 dB to 100.0 dB (in 0.1 dB steps) when the impedance is set to Other (75 ohms). Set to 1.9 dB when using the MA1621A impedance transformer as the impedance converter.</p> <p>Back: Press this submenu key to return to the “Meas Setup (2/2) (Delay Profile) Menu” or to the “Meas Setup (2/2) (Inband Spectrum) Menu”.</p>
---	--

Figure 5-14. Correction Value Menu

5-18 Delay Profile Vertical Range Menu

Key Sequence: **Meas Setup** > Delay Profile > More > Delay Profile Vertical Range

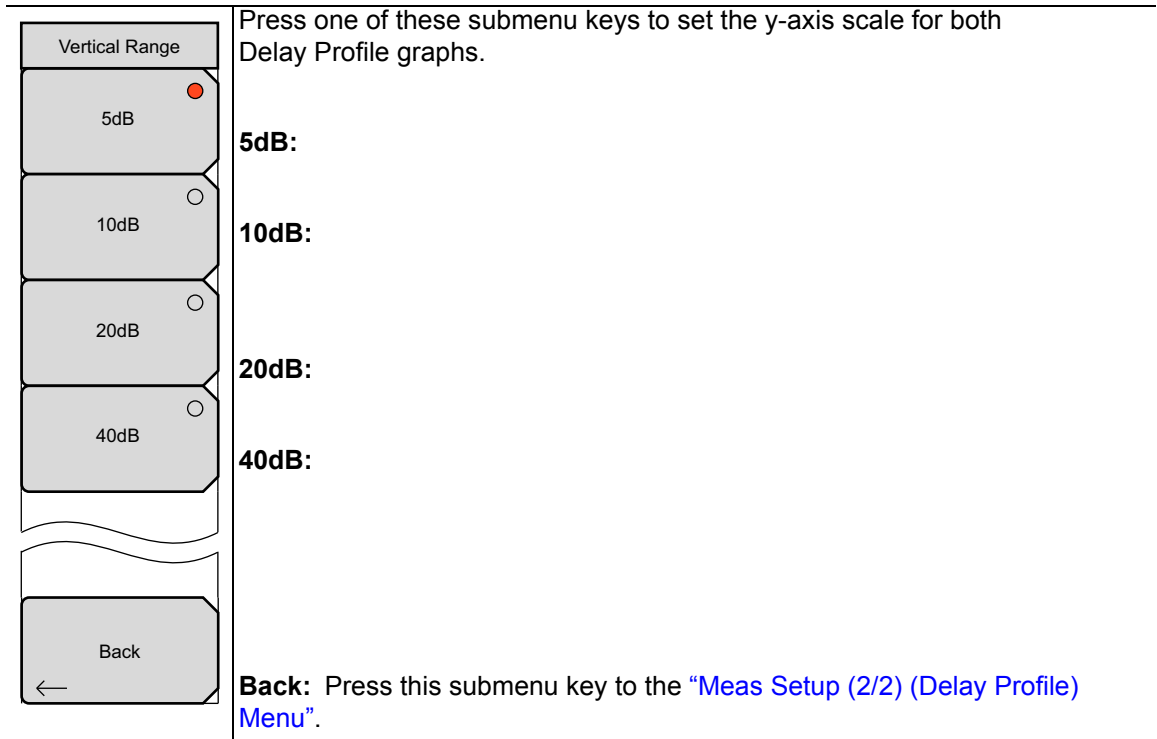


Figure 5-15. Vertical Range Menu (Delay Profile)

5-19 Display Waveform Menu

Key Sequence: **Meas Setup** > Delay Profile > More > Display Waveform

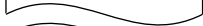


Display Waveform	
Last Result <input type="radio"/> On <input type="radio"/> Off	Last Result On Off: Press this submenu key to toggle On and Off a display of the last measurement waveform (yellow).
Power Method <input type="radio"/> On <input type="radio"/> Off	Power Method On Off: Press this submenu key to toggle On and Off a display of the delay path profile waveform (light blue) that is created by the power spectrum method.
Transfer Method <input type="radio"/> On <input type="radio"/> Off	Transfer Method On Off: Press this submenu key to toggle On and Off a display of the delay path profile waveform (magenta) that is created by the transfer function method.
	
	
Back 	Back: Press this submenu key to the “Meas Setup (2/2) (Delay Profile) Menu” .

Figure 5-16. Display Waveform Menu

5-20 Inband Spectrum Vertical Range Menu

Key Sequence: **Meas Setup** > Inband Spectrum > More > Inband Spectrum Vertical Range

Press one of these submenu keys to set the y-axis scale for the Inband Spectrum graphs.

5dB:

10dB:

25dB:

50dB:

Back: Press this submenu key to return to the [“Meas Setup \(2/2\) \(Inband Spectrum\) Menu”](#).

Figure 5-17. Vertical Range Menu (Inband Spectrum)

Vertical Range and Correlating dB Values

Table 5-4. Vertical Range with Correlating dB Value

Vertical Range (dB)	Value (dB)
5	1 to -4
10	2 to -8
25	5 to -20
50	10 to -40

Index

Numerics

- 0 microsecond position
 - DVB-T/H FFT Start 2-4
 - DVB-T/H Impulse Response 2-34
 - ISDB-T Delay Profile 4-31
 - ISDB-T FFT Start 4-4
- 1, 2, 3 modes in ISDB-T 1-4, 4-4
- 2K, 4K, 8K modes in DVB-T/H ... 1-4, 2-3

A

- advanced settings menu, DVB-T/H .. 2-50
- amplitude menu
 - DVB-T/H 2-45, 2-46
 - DVB-T/H SFN 3-12
- amplitude setup, DVB-T/H 2-22
- Anritsu, contact 1-2
- antenna setup
 - DVB-T/H 2-19
 - DVB-T/H SFN 3-4
 - DVB-T/H SFN 3-5
 - ISDB-T 4-5
- ASI Out
 - connector, ISDB-T 4-47
- auto detect parameter
 - DVB-T/H 2-23
 - DVB-T/H submenu key 2-48
- auto reference level
 - DVB-T/H 2-22, 2-46
 - DVB-T/H SFN 3-12
 - ISDB-T 4-6, 4-72
 - ISDB-T SFN 5-14
 - with DVB-T/H input attenuator . 2-47
 - with DVB-T/H SFN input attenuator . 3-13
 - with ISDB-T SFN input attenuator 5-15
- automatic parameter detection
 - DVB-T/H, concepts 2-16
 - DVB-T/H, FFT Start 2-50
 - DVB-T/H, quick measurements . 2-23
 - DVB-T/H, submenu keys 2-48

B

- bandwidth setup
 - DVB-T/H 2-21
 - DVB-T/H SFN 3-5
 - ISDB-T modulation analysis 4-22
 - ISDB-T quick start 4-6

- bandwidth submenu key
 - DVB-T/H 2-44
 - DVB-T/H SFN 3-11
 - ISDB-T 4-6, 4-68
- batch measurements in ISDB-T 4-9
- BER
 - DVB-T/H measurement 2-37
 - ISDB-T meas setup, custom 4-47
 - ISDB-T meas setup, easy 4-15
 - setup menu, DVB-T/H 2-59, 2-60, 2-61
 - setup menu, ISDB-T 4-63, 4-97
 - submenu key, DVB-T/H 2-51
 - submenu key, ISDB-T 4-64
- bit error rate (BER)
 - option 57, DVB-T/H 2-15
 - option 79, ISDB-T 4-47

C

- carrier MER menu, DVB-T/H 2-58
- carrier MER view, DVB-T/H 2-35
- carrier-to-noise ratio, MPE-FEC 2-4
- channel map
 - DVB-T/H signal standards 2-44
 - DVB-T/H SFN signal standards .. 3-11
 - ISDB-T batch setup 4-9
 - ISDB-T batch setup common items 4-13
 - ISDB-T channel or frequency ... 4-22
 - ISDB-T configuration 4-6
 - ISDB-T critical mask, UHF Brazil 4-35
 - ISDB-T easy setup common items 4-17
 - ISDB-T masks for channel map . 4-34
 - ISDB-T noncritical mask, UHF Brazil 4-37
 - ISDB-T subcritical mask, UHF Brazil 4-36
- composite view, DVB-T/H 2-30
- constellation configuration menu
 - ISDB-T 4-79
- constellation menu, DVB-T/H 2-55
- constellation view, DVB-T/H 2-32
- constellation zoom menus
 - ISDB-T 4-80
- contacting Anritsu 1-2
- converter, external impedance 4-76
- correction value menu
 - ISDB-T SFN 5-23
- custom measurements, ISDB-T 4-20

D

damage warning, pre amp 4-69

default filter parameter
 ISDB-T channel map 4-38

delay profile configuration menu
 ISDB-T 4-82

delay profile freq response
 vertical range menu, ISDB-T 4-84

delay profile vertical range menu
 ISDB-T 4-83
 ISDB-T SFN 5-24

display waveform menu
 DVB-T/H SFN 3-18
 ISDB-T SFN 5-25

Doppler effect
 DTV signals 1-4
 DVB-T/H 2-3
 ISDB-T 4-4

DVB ASI Out
 connector, DVB-T/H 2-37

DVB-H described 2-3

DVB-T described 2-2

DVB-T/H
 menu group 2-40

DVB-T/H SFN
 menu group 3-8

E

easy measurement parameters, ISDBT 4-17

easy measurements, ISDB-T 4-15

echo interference, guard interval
 DTV 1-7
 DVB-T/H 2-3
 ISDB-T 4-4

error correction, DVB-H 2-3

example, DVB-T/H
 amplitude setup 2-22
 BER measurement 2-38
 carrier MER 2-35
 composite view 2-30
 constellation 2-32
 impulse response 2-34
 quick measurement setup 2-23
 shoulder attenuation 2-29
 signal power 2-25
 spectrum monitor 2-27

example, DVB-T/H SFN

 amplitude 3-5
 antenna setup 3-4
 bandwidth 3-5
 frequency setup 3-4
 impulse response measurement . . 3-7
 inband spectrum measurement . . . 3-7
 measurement setup 3-5

example, ISDB-T

 quick start in all modes 4-5
 antenna setup 4-5
 batch measurement preparation . . 4-9
 batch setup 4-11
 custom BER setup 4-47
 custom constellation setup 4-26
 custom delay profile setup 4-31
 custom field strength setup 4-20
 custom modulation analysis setup 4-22
 custom phase noise setup 4-44
 custom setup 4-20
 custom spectrum mask setup . . . 4-34
 custom spectrum monitor setup . . 4-49
 custom spurious emissions setup 4-46
 easy field strength setup 4-15
 easy measurements, general setup 4-15
 easy modulation analysis setup . . 4-16
 easy spectrum mask setup 4-16
 easy spurious emissions setup . . . 4-17
 freq and reference level config . . . 4-6
 saving file manually 4-54

example, ISDB-T SFN

 antenna setup 5-2
 delay profile setup 5-4
 inband spectrum setup 5-5
 measurement setup 5-3

external impedance converter 4-76

F

FFT Start

 description of purpose 1-7
 DVB-T/H auto detection 2-17
 DVB-T/H position 2-4
 DVB-T/H submenu key 2-50
 ISDB-T auto detection 4-4
 ISDB-T submenu key 4-85

- field strength
 - DVB-T/H SFN 3-1
 - ISDB-T batch mode 4-14
 - ISDB-T custom mode 4-20
 - ISDB-T easy mode 4-18
 - ISDB-T measurement 4-7
 - ISDB-T setup 4-15
 - ISDB-T setup menu 4-73
 - menu group, ISDB-T 4-67
- file menu, ISDB-T 4-54
- freq menu
 - DVB-T/H 2-44
 - DVB-T/H SFN 3-11
- frequency measurement setup
 - DVB-T/H 2-20
 - DVB-T/H SFN 3-4
- frequency/level menu
 - IF Channel Map 4-70
 - ISDB-T SFN 5-12, 5-13
 - None Channel Map 4-71
 - UHF Channel Map 4-68
- G**
- guard interval (GI)
 - DVB-T/H 2-3
 - ISDB-T 4-4
 - purpose 1-7
- H**
- hierarchical modulation, DVB-T/H ... 2-5
- HP
 - data stream, hierarchical modulation 2-5
 - high priority data stream 2-2
- http, contacting Anritsu 1-2
- I**
- impedance
 - external converter 4-76
 - instrument, default 4-76
- impulse response
 - DVB-T/H measurement 2-33
 - DVB-TH SFN measurement .. 3-2, 3-7
 - menu, DVB-T/H 2-56
- impulse response menu
 - DVB-T/H SFN 3-16
- inband spectrum
 - DVB-TH SFN measurement .. 3-3, 3-7
- inband spectrum menu
 - DVB-T/H SFN 3-19
- inband spectrum vertical range menu
 - ISDB-T SFN 5-26
- instrument damage warning, pre amp 4-69
- instrument impedance, default 4-76
- IP datagrams, DVB-H 2-3
- ISDB-T
 - 8 MHz bandwidth measurement . 4-51
 - antenna setup 4-5
 - bandwidth submenu key 4-6, 4-68
 - batch measurements 4-9
 - custom measurements 4-20
 - delay profile graph colors 4-32
 - easy measurements 4-15
 - freq and reference level 4-6
 - menu group 4-55
 - one-seg measurement 4-33
 - one-seg submenu key 4-68
 - TMCC information editor 4-86
 - TMCC submenu key 4-81
 - UHF (Brazil) channel map filter . 4-38
- L**
- link layer, DVB-H 2-3
- links
 - contacting Anritsu 1-2
- LP
 - data stream, hierarchical modulation 2-5
 - low priority data stream 2-2
- M**
- marker menu
 - DVB-T/H 2-52
 - DVB-T/H SFN 3-20, 3-21
 - ISDB-T 4-87
 - ISDB-T SFN, delay profile 5-17
 - ISDB-T SFN, inband spectrum .. 5-18
- meas selection menu
 - DVB-T/H 2-51
 - DVB-T/H SFN 3-16
 - ISDB-T 4-64

measure setup menu	
DVB-T/H	2-48
DVB-T/H SFN	3-15
ISDB-T field strength	4-73
ISDB-T modulation analysis	4-77, 4-78
ISDB-T modulation, custom	4-82
ISDB-T phase noise	4-95
ISDB-T phase noise, custom	4-95
ISDB-T spectrum mask	4-93
ISDB-T spectrum monitor, custom	4-98
ISDB-T spurious emissions	4-96
ISDB-T spurious emissions, custom	4-96
ISDB-T, spectrum monitor	4-98
ISDB-T SFN	5-16, 5-19, 5-21
ISDB-T SFN inband spectrum	5-21
ISDB-T SFN measurement	5-10, 5-16, 5-19
measurement	
DVB-T/H BER	2-37
DVB-T/H carrier MER	2-35
DVB-T/H composite view	2-30
DVB-T/H constellation view	2-32
DVB-T/H frequency setup	2-20
DVB-T/H impulse response	2-33
DVB-T/H modulation analysis	2-13, 2-30
DVB-T/H RF shoulder attenuation	2-29
DVB-T/H RF signal power	2-25
DVB-T/H RF spectrum monitor	2-27
DVB-T/H SFN antenna setup	3-5
DVB-T/H SFN bandwidth setup	3-5
DVB-T/H SFN freq setup	3-4
DVB-T/H SFN impulse response	3-2, 3-7
DVB-T/H SFN inband spectrum	3-3, 3-7
ISDB-T 8 MHz bandwidth	4-51
ISDB-T one-seg	4-33
measurement results, saving	4-52
menu group	
DVB-T/H	2-40
DVB-T/H SFN	3-8
ISDB-T	4-55
ISDB-T field strength	4-67
menu, DVB-T/H	
advanced settings	2-50
amplitude	2-45, 2-46
BER setup	2-59, 2-60, 2-61
carrier MER	2-58
constellation	2-55
freq	2-44
impulse response	2-56
marker	2-52
meas selection	2-51
meas setup	2-48
modulation analysis	2-55
RF measurements	2-53
signal power	2-53
spectrum monitor	2-54
vertical range, carrier MER	2-58
vertical range, impulse response	2-57
menu, DVB-T/H SFN	
amplitude	3-12
display waveform	3-18
freq	3-11
impulse response	3-16
inband spectrum	3-19
marker	3-20, 3-21
meas selection	3-16
setup	3-14, 3-15
vertical range, impulse response	3-17
vertical range, inband spectrum	3-19
menu, ISDB-T	
constellation configuration	4-79
constellation zoom	4-80
delay profile configuration	4-82
delay profile freq response vertical range	4-84
delay profile vertical range	4-83
frequency/level IF Channel Map	4-70
frequency/level None Channel Map	4-71
frequency/level UHF Channel Map	4-68
marker	4-87
meas selection	4-64
meas setup, BER	4-97
meas setup, field strength	4-73
meas setup, modulation analysis	4-77, 4-78
meas setup, phase noise	4-95
meas setup, spectrum mask	4-93
meas setup, spectrum monitor	4-98
meas setup, spurious emissions	4-96

- menu, ISDB-T SFN
 - correction value 5-23
 - delay profile vertical range 5-24
 - display waveform 5-25
 - frequency/level 5-12, 5-13
 - inband spectrum vertical range 5-26
 - marker, delay profile 5-17
 - marker, inband spectrum 5-18
 - meas setup 5-16, 5-17, 5-19, 5-21
 - TMCC information 5-22
- MER
 - carrier MER menu, DVB-T/H 2-58
 - carrier MER, DVB-T/H 2-35
 - carrier MER, illustration 2-14
 - carrier, DVB-T/H described 2-14
 - ISDB-T modulation analysis 4-7
 - ISDB-T sub-carrier MER 4-16
 - ISDB-T sub-carrier MER key 4-77, 4-78
 - ISDB-T, constellation zoom 4-80, 4-81
 - with option 57 2-15
- modes 1, 2, 3 in ISDB-T 1-4, 4-4
- modes 2K, 4K, 8K in DVB-T/H 1-4, 2-3
- modulation analysis
 - DVB-T/H measurement 2-13, 2-30
 - menu, DVB-T/H 2-55
- modulation error ratio (MER), option 57 2-15
- MPE-FEC, DVB-H link layer 2-3
- MPE-FEC, DVB-T/H uses 2-4
- MPEG-TS data output 2-37
- MSB (most significant bits) 2-2
- multi-protocol encapsulation (MPE) 2-3
- N**
- noise floor and input attenuation
 - ISDB-T SFN 5-14
- O**
- OFDM and guard interval 1-7
- OFDM, DVB-T/H 2-3
- OFDM, ISDB-T 4-4
- one-seg submenu key, ISDB-T 4-68
- option
 - 30, ISDB-T 4-1
 - 32, ISDB-T SFN 5-1
 - 57, DVB-T/H BER, main topic 2-1
 - 64, DVB-T/H, main topic 2-1
 - 78, DVB-T/H SFN, main topic 3-1
 - 79, ISDB-T BER, main topic 4-47
 - 9, IQ Demod hardware 2-1, 3-1, 4-1
 - MS8911B-0050 1-1
 - MS8911B-0055 1-1
- P**
- packet error rate (PER)
 - option 57 2-15
 - option 79 4-47
- parameter detection
 - DVB-T/H 2-16
- parity information, MPE-FEC 2-4
- PER
 - option 57 2-15
 - option 79 4-47
- physical layer, DVB-H 2-3
- Pilot signals 2-3
- pre amp
 - instrument damage warning 4-69
- propagation delays, guard interval
 - DTV 1-7
 - DVB-T/H 2-3
 - ISDB-T 4-4
- Q**
- QAM 2-2
- QPSK 2-2
- quick measurement, DVB-T/H 2-23
- R**
- reference level, DVB-T/H 2-22
- RF measurement, DVB-T/H 2-25
- RF measurements menu, DVB-T/H 2-53
- S**
- saving file manually, ISDB-T 4-54
- saving measurement results 4-52
- setup ISDBT
 - batch measurements 4-9
 - delay profile 4-29
 - easy measurements 4-15
- setup menu
 - DVB-T/H 2-48
 - DVB-T/H BER 2-59, 2-61
 - DVB-T/H quick measurement 2-23
 - DVB-T/H SFN 3-14, 3-15
 - ISDB-T BER 4-63
 - ISDB-T constellation 4-61
 - ISDB-T delay profile 4-62
 - ISDB-T field strength 4-67
 - ISDB-T field strength, custom 4-73
 - ISDB-T modulation analysis 4-60
 - ISDB-T modulation analysis, custom

4-77

ISDB-T modulation analysis, easy 4-78

ISDB-T modulation, custom 4-82

ISDB-T phase noise, custom 4-95

ISDB-T SFN inband spectrum . . 5-21

ISDB-T SFN measurement 5-10, 5-16, 5-19

ISDB-T spectrum mask 4-93

ISDB-T spectrum monitor, custom 4-98

ISDB-T spurious emissions, custom 4-96

setup procedure ISDBT

 batch measurements 4-11

 batch, easy, custom 4-7

 custom BER 4-47

 custom field strength 4-20

 custom measurements 4-20

 custom modulation analysis 4-22

 custom phase noise 4-44

 custom spectrum mask 4-34

 custom spectrum monitor 4-49

 custom spurious emissions 4-46

 easy field strength 4-15

 easy measurements, general 4-15

 modulation analysis 4-16

 spectrum mask 4-16

 spurious emissions 4-17

shoulder attenuation

 DVB-T/H RF measurement 2-29

signal power

 DVB-T/H RF measurement 2-25

 menu, DVB-T/H 2-53

signal standard, DVB-T/H 2-21

spectrum mask

 UHF (Brazil) 4-16

spectrum monitor

 DVB-T/H RF measurement 2-27

 menu, DVB-T/H 2-54

symbol duration

 DTV signals 1-4

 DVB-T/H 2-3

 ISDB-T 4-4

T

test setup example

 DVB-T/H signal standard 2-21

 DVB-T/H BER 2-38

 ISDB-T BER 4-48

time-slicing

 DVB-H 2-3

 DVB-T/H 2-4

TMCC information editor, ISDB-T . . 4-86

TMCC information menu

 ISDB-T 4-24

 ISDB-T SFN 5-22

TMCC submenu key

 ISDB-T 4-81

 ISDB-T SFN 5-19

TPS-bits 2-3

transmission parameter signaling

 TPS bits 2-3

U

UHF (Brazil), spectrum mask setup . 4-16

URL contacting Anritsu 1-2

V

vertical range menu

 DVB-T/H carrier MER 2-58

 DVB-T/H impulse response 2-57

 DVB-T/H SFN impulse response . 3-17

 DVB-T/H SFN inband spectrum . 3-19

W

warning

 damage at preamplifier setting . . 4-69

 instrument damage 5-12, 5-13

 instrument damage and preamp . 5-14

website, contacting Anritsu 1-2

Z

zero microsecond position, DVB-T/H . 2-33

Anritsu



Anritsu prints on recycled paper with vegetable soybean oil ink.

Anritsu Company
490 Jarvis Drive
Morgan Hill, CA 95037-2809
USA
<http://www.anritsu.com>