

**Measurement Guide**

# **CPRI LTE RF Analyzer and BBU Emulator**

**for Anritsu RF and Microwave Handheld Instruments**

CPRI – Common Public Radio Interface

BBU – Base Band Unit

The Anritsu logo is displayed in a blue, sans-serif font. The letter 'A' is stylized with a diagonal slash through it.



# Table of Contents

---

## Chapter 1—General Information

1-1	Introduction . . . . .	1-1
1-2	Selecting a Measurement Mode . . . . .	1-1
1-3	Contacting Anritsu . . . . .	1-2

## Chapter 2—CPRI LTE RF Analyzer

2-1	Introduction . . . . .	2-1
2-2	Setup Requirements and Checklist . . . . .	2-2
2-3	Typical CPRI Connection . . . . .	2-3
2-4	CPRI Parameters . . . . .	2-4
	Line Rate . . . . .	2-4
	CPRI Bandwidth . . . . .	2-5
	AxC Group . . . . .	2-5
	Reserve Containers . . . . .	2-5
	IQ Bit Width . . . . .	2-6
	Reserve Bits . . . . .	2-6
	CPRI Aggregation . . . . .	2-6
	IQ Bit Mapping . . . . .	2-7
2-5	CPRI Configuration . . . . .	2-7
	Radio Presets . . . . .	2-7
	CPRI Parameter Automatic Detection . . . . .	2-8
2-6	CPRI Measurement Display . . . . .	2-9
	CPRI Spectrum . . . . .	2-9
	Spectrogram . . . . .	2-10
2-7	CPRI Configuration Example . . . . .	2-12
2-8	Base Band Unit Emulation (Option 760) . . . . .	2-14
	Remote Electrical Tilt Device Test (Option 761) . . . . .	2-14
	BBU Script Download . . . . .	2-15
	LTE Waveform Download . . . . .	2-15
	BBU Test . . . . .	2-17
2-9	PIM Over CPRI (Option 754) . . . . .	2-29
	PIM Over CPRI Configuration Settings . . . . .	2-30
	PIM Configuration and Measurement Procedure . . . . .	2-34
	Results Table . . . . .	2-36
	Reset Measurements . . . . .	2-37

## Table of Contents (Continued)

---

2-10	CPRI Analyzer Menu Map	2-38
	Measurements Menu Map	2-40
	Sweep Menu	2-45
	Trace Menus	2-45
	Limit Menus	2-46
2-11	Freq Menu	2-47
2-12	Span Menu	2-50
2-13	Amplitude Menu	2-51
2-14	Units of External Gain or Loss	2-51
2-15	Bandwidth Menu	2-52
2-16	Measure Menu	2-53
2-17	BBU Emulation Menu (Option 760 Only)	2-55
2-18	Script Manager Menu	2-56
2-19	BBU Test Menu	2-58
2-20	RET Test Menu	2-60
2-21	BBU RF Test Menu	2-61
2-22	LTE Waveforms Menu	2-62
2-23	RL/VSWR Menu	2-65
2-24	CPRI Config Menu	2-66
2-25	SFP Port Config Menu	2-67
2-26	Radio Presets Menu	2-68
2-27	Custom Settings Menu	2-70
2-28	Auto Detect Menu	2-71
2-29	Display Config Menu	2-72
2-30	AxC Trace Config Menu	2-73
2-31	CPRI Spectrum Menu	2-74
2-32	Spectrogram Menu	2-75
2-33	Display Setup Menu	2-76
2-34	CPRI SFP Data Menu	2-78
2-35	PIM Over CPRI Menu (Option 754 Only)	2-80
2-36	Marker Menu	2-82
2-37	Marker 2/2 Menu	2-84
2-38	Sweep Menu	2-85
2-39	Trace Menu	2-86
2-40	Trace A Ops Menu	2-87
2-41	Trace B Ops Menu	2-88

## Table of Contents (Continued)

---

2-42	Trace C Ops Menu .....	2-89
2-43	Limit Menu .....	2-90
2-44	Limit Move Menu .....	2-91
2-45	Save Menu .....	2-92
2-46	Save Location Menu.....	2-94
2-47	Recall Menu .....	2-96

### **Index**



# Chapter 1 — General Information

## 1-1 Introduction

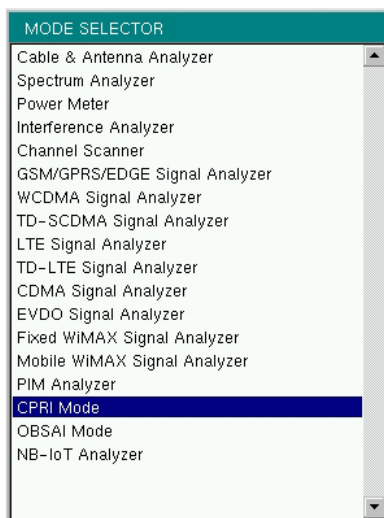
This measurement guide describes the Common Public Radio Interface (CPRI) analyzer test and measurement functions of Anritsu RF and Microwave Handheld Instruments. Basic spectrum analyzer functions are documented in the Spectrum Analyzer Measurement Guide. Other functions are available only when the related option is installed and activated. These features are documented in their respective Measurement Guides. Refer to the instrument User Guide for a list of options and their related manuals.

Screen captured images contained in this document are provided as examples. Illustrations of menu maps, or menu trees, may show submenu keys that display only under certain conditions. The actual displays, screen menus, and measurement details may differ based on instrument model, firmware version, installed options, and current instrument settings.

## 1-2 Selecting a Measurement Mode

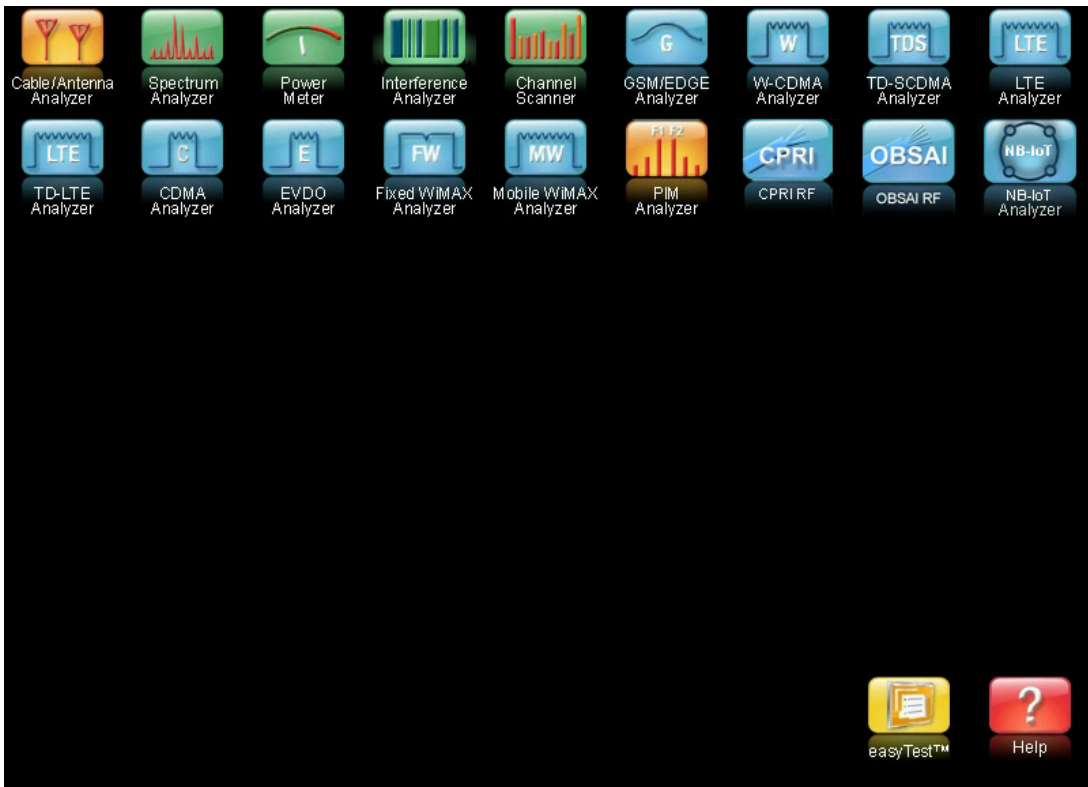
To switch from the current measurement mode, or application, to another:

1. Press the **Shift** front panel key, followed by **Mode (9)**. The Mode Selector dialog opens.
2. Use the arrow keys or rotary knob, or tap the touch screen to highlight the desired measurement mode. The list of available applications depends on the options that are installed and activated on your instrument. See [Figure 1-1](#).
3. Press **Enter**.



**Figure 1-1.** Mode Selector Dialog Box

On instruments that have a front panel **Menu** key, an alternate method of changing the measurement mode is to press **Menu**, then press the appropriate application icon on the touch screen.



**Figure 1-2.** Menu Key Screen – Application Icons and User-Defined Shortcuts

### 1-3 Contacting Anritsu

To contact Anritsu, please visit:

<http://www.anritsu.com/contact-us>

On this page, you can find links to sales, service, and support contact information for your country or region. You can also provide online feedback, complete a “Talk to Anritsu” form to have your questions answered, or obtain other services offered by Anritsu.

Updated product information can be found on the Anritsu website:

<http://www.anritsu.com/>

Search for the product model number. The latest documentation is on the product page, under the Library tab.

# Chapter 2 — CPRI LTE RF Analyzer

## 2-1 Introduction

The Common Public Radio Interface (CPRI) is a protocol standard for wireless communications between remote radio heads, also referred to as Radio Equipment (RE), and the Radio Equipment Controller (REC). The main differences with traditional RF signals are summarized in [Table 2-1](#).

**Table 2-1.** CPRI Signal Characteristics (Compared to RF)

RF	CPRI
Analog	Digital
Absolute measurements	Relative measurements
dBm	dB
Specific center frequency	Base Band
Absolute power levels	Relative power levels
Full Span capable	Max Span = Carrier BW + 50%

Anritsu's CPRI LTE RF Analyzer (Option 752) allows users to make RF-based measurements over a fiber optic CPRI link to look for interference problems affecting a Remote Radio Head (RRH). This is accomplished by tapping into the fiber link between the RRH and BBU (Base Band Unit), using an optical splitter to connect the RRH and BBU to the Anritsu test instrument. The instrument will decode the CPRI protocol IQ data and convert it to RF data.

**Note**

Option 752 requires Option 759, RF over Fiber Hardware. Depending on your Anritsu test instrument model, Option 759 may have a single or dual SFP ports. Refer to your instrument Technical Data Sheet for specifications. The combination of Option 759 and Option 752 is functionally identical to the obsolete Option 751.

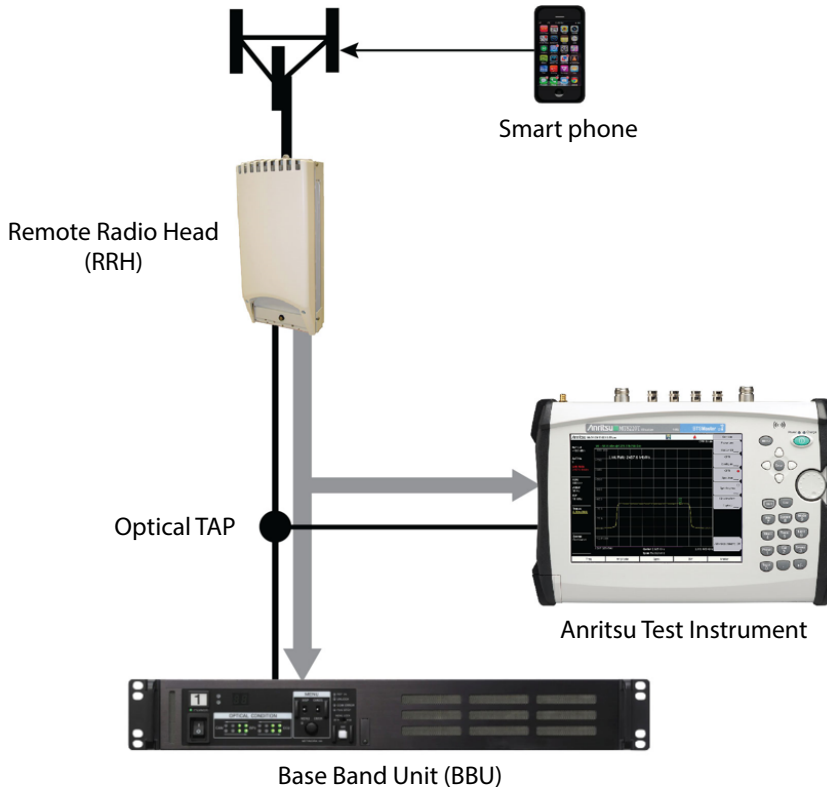
Screen displays vary with the installed option and instrument model being used. The screen captures illustrated in this document are examples and may differ from your instrument display.

Some functions and parameter settings described in this manual are available only in firmware version 2.6 and later. Refer to your instrument User Guide for instructions on upgrading firmware.

Two types of CPRI measurements are available:

- Spectrum mode is typically used to test the CPRI link in real time.
- Spectrogram mode lets users monitor for intermittent interference over a specifiable recording time.

These CPRI Analyzer test and measurement functions can be performed from ground level, eliminating the risk and costs of climbing towers. [Figure 2-1](#) illustrates a typical connection configuration for CPRI LTE RF testing with an Anritsu test instrument.



**Figure 2-1.** Connection Configuration for CPRI LTE RF Testing with Anritsu Test Instrument

## 2-2 Setup Requirements and Checklist

Following is a list of required accessories and questions to be answered to successfully set up a CPRI connection for testing. Refer to your Anritsu test instrument's Technical Data Sheet for available accessories.

- SFP optical transceiver used to connect the measurement device must match the link rate of SFPs on the BBU and RRH. Different options are available from Anritsu, with single or dual SFP ports.
- Optical splitter or TAP (Test Access Point), Single Mode or Single/Multi Mode
- Optical cables
- What is the bandwidth of LTE carrier?
- Who is the network equipment manufacturer (NEM)?
- What is the CPRI line rate (or link rate)?
- Is the fiber optic connection Single Mode (Yellow) or Multi Mode (Orange)?

### Caution



Exercise caution when handling SFPs that are connected to equipment in use, as they can become hot to the touch.

## 2-3 Typical CPRI Connection

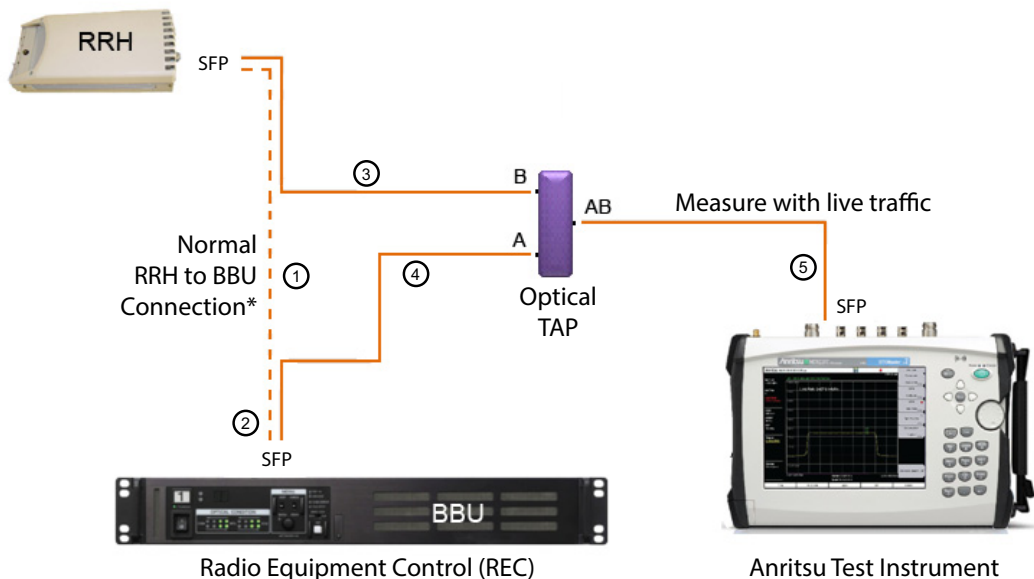
1. Lock down the RRH before disconnecting the fiber optic cable.
2. Disconnect the fiber cable from the BBU.
3. Connect the RRH to Port B on the optical TAP.
4. Connect a 3-meter LC/LC Duplex Jumper from Port A on the optical TAP to the BBU.
5. Use a compatible SFP transceiver and Simplex fiber cable to connect the Anritsu test instrument to Port AB on the optical TAP.

Port A Out from Port AB is the downlink BBU signal.

Port B Out from Port AB is the uplink RRH signal.


6. If your test instrument has dual SFP ports, you can optionally connect it to another RE, using the second port.
7. When all connections are complete, unlock the RRH.
8. Perform measurements using live traffic.

Radio Equipment (RE)



\* Lock down the Radio before disconnecting fiber from BBU

**Figure 2-2.** Connecting CPRI Link to Anritsu Test Instrument

<p><b>Warning</b></p> 	<p>Laser radiation may be present at fiber optic cable connectors and ports. This laser radiation could present a nominal ocular hazard from either direct viewing or by diffuse reflection. Do not view the emitted laser radiation directly or indirectly because permanent blindness may result.</p>
---	---

## 2-4 CPRI Parameters

When monitoring traffic over the CPRI link, the Anritsu test instrument will extract the IQ data and process the signal into data points to be plotted on the instrument screen. The CPRI parameters described in the following sections are needed for the CPRI Analyzer to process and display the data correctly. Note that configurations may be different for the uplink and downlink. The uplink signal represents mobile phone LTE data. The downlink signal is the display of BBU LTE signals to RRH.

All CPRI IQ data is at baseband frequency. To allow the CPRI signal to move off center (pan), turn the Center Frequency Reference setting on and adjust the center frequency to a different value. Depending on the value entered, this may automatically adjust the frequency span, as there cannot be panning without zooming. Refer to [“Freq Menu” on page 2-47](#).

### Note

Some CPRI parameter settings like line rate, LTE carrier bandwidth, and AxC group and port selections for traces can be selected both in the CPRI configuration and the PIM Over CPRI configuration (Option 754 only). Refer to [“PIM Over CPRI Configuration Settings” on page 2-30](#).

When saved and applied to PIM measurements from the PIM Aid configuration dialog, these settings remain in effect after you exit PIM Over CPRI mode and change to CPRI Spectrum mode, for example.

### Line Rate

Line Rate is the speed of the CPRI link. [Table 2-2](#) lists the selectable line rates and associated rate numbers, 1 through 8. The 10 Gbit/s line rate is available with firmware version 2.6 and later. If needed, refer to your instrument User Guide for firmware upgrade instructions.

The instrument display shows the line rate on the left side of the screen. On models with dual SFP ports, the top value is the line rate of SFP Port 1 and the bottom value is SFP Port 2 line rate. Refer to [“SFP Port Config Menu” on page 2-67](#).

**Table 2-2.** CPRI Line Rates

CPRI Rate	Line Rate (Mbit/s)
1	614.4
2	1228.8
3	2457.6
4	3072.0
5	4915.2
6	6144.0
7	9830.4
8	10137.6

## CPRI Bandwidth

This is the bandwidth of the LTE carrier that is transmitted via CPRI. Supported LTE carrier bandwidths are 5 MHz, 10 MHz, 15 MHz, and 20 MHz.

The IQ data includes the LTE carrier plus 50% dummy data, which appears as noise floor on either side of the spectrum. The maximum span is approximately 50% greater than the carrier bandwidth. For example, if the LTE carrier bandwidth is 10 MHz, the maximum span will be about 15 MHz.

In spectrum dual display mode, you can configure each of Display 1 and 2 for a different CPRI bandwidth. The selected bandwidth of the currently active display is shown on the left side of the sweep window. The dual display feature is available with firmware version 2.6 and later.

## AxC Group

The CPRI Antenna Carrier (AxC) Container transports the IQ data used to generate the RF spectrum. AxC mapping determines the location of IQ data for a given carrier. The number of AxC containers required to carry the CPRI data and the location of such AxC container groups in the data stream – as determined by an AxC group number starting from 0 – are specific to the carrier and bandwidth.

**Table 2-3.** Bandwidth and AxC Containers Required

Carrier Bandwidth	AxC Containers Required in a Group
5 MHz	2
10 MHz	4
15 MHz	6
20 MHz	8

Some LTE equipment manufacturers may choose to apply undersampling to compress 20 MHz CPRI signal data into 6 containers per group instead of 8. (Firmware version 2.6 or later is required.) In this instance, choose the Compress Sampling Rate setting under the AxC Trace menu. Refer to [“Sampling Rate” on page 2-73](#).

To associate an AxC group with an SFP port, go to the [“AxC Trace Config Menu”](#). The selected AxC group for each of traces 1 through 4 are displayed at the top left of the instrument screen.

## Reserve Containers

Most radio manufacturers start the IQ samples at the beginning of the CPRI stream. Some LTE carriers, however, may employ a frame structure where a number of containers at the start of the CPRI data flow are reserved, thereby offsetting the location of the first AxC group (AxC0). In this case, set a Reserve Container Count to shift the start location of the IQ data block. Refer to [“Custom Settings Menu” on page 2-70](#). For example, a Reserve Container Count of 4 will offset the location of container group AxC0 to container number 4, skipping the reserve containers 0 through 3. See [Figure 2-3](#).

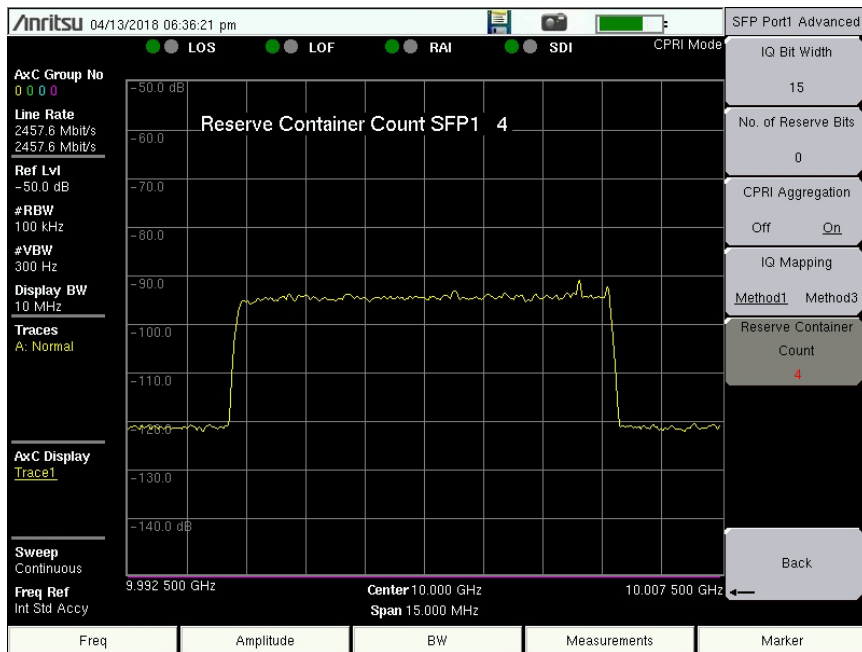


Figure 2-3. Reserve Container Count

### IQ Bit Width

This is the IQ bit width, or sample width, for the digitized uplink and downlink signals. The parameter value is determined by the Radio Equipment Manufacturers. Selectable values are 10, 12, 15, and 16.

### Reserve Bits

The reserve (or stuffing) bits are vendor-specific and are used with IQ bit width to align sample frequencies to the CPRI frame. Reserve bits can be set at 0 through 10. For LTE, 0 and 6 are the most common reserve bit values.

### CPRI Aggregation

Aggregation is common with some LTE equipment manufacturers. It refers to the aggregation of smaller carriers to make one large carrier within one AxC. For example, two 5 MHz carriers can be aggregated to make a single 10 MHz carrier.

**Note**

If you know the equipment manufacturer, such as Nokia/ALu (Alcatel-Lucent), Ericsson, Huawei, or Samsung, you may select the appropriate radio preset and let the application auto-detect the line rate, the carrier bandwidth, and any available antenna carrier (AxC) groups. Refer to [“CPRI Parameter Automatic Detection” on page 2-8.](#)

To select CPRI parameter settings without the aid of a radio preset, refer to the [“CPRI Config Menu” on page 2-66.](#)

## IQ Bit Mapping

Your Anritsu test instrument supports two IQ mapping methods. Method 1 is intended for dense packing of IQ data. Mapping method 3 is backward compatible with early releases of the CPRI specification.

## 2-5 CPRI Configuration

The primary application for CPRI LTE RF is to check for interference on the RRH-to-BBU uplink. The easiest way to configure the Anritsu instrument for CPRI testing is to select one of the radio presets provided with the CPRI application, then use the Auto Detect feature to automatically determine and apply the appropriate configuration settings.

If no radio preset is available for the RRH being tested or you don't know who the equipment manufacturer is, you can still use the Auto Detect feature by entering custom settings for the IQ bit width, number of reserve bits, and aggregation condition. Set these parameters via the [“Custom Settings Menu” on page 2-70](#) or the Auto-Detect dialog illustrated in [Figure 2-7](#).

Other parameters required in configuring the CPRI link are the line rate, the LTE carrier bandwidth, and the AxC group number. Refer to [“CPRI Parameters” on page 2-4](#) and [“CPRI Config Menu” on page 2-66](#).

### Radio Presets

Radio presets are currently available for the uplink and downlink signals associated with specific equipment manufacturers like Nokia/ALu (Alcatel-Lucent), Ericsson, Huawei, or Samsung.

- Uplink – RRH to BBU
- Downlink – BBU to RRH

To choose a radio preset:

1. Press the **Measurements** key in CPRI Mode.
2. Press CPRI Configure, then select SFP Port1 Config or SFP Port2 Config, as appropriate (dual-port models only).
3. Press Radio Presets.
4. Press the appropriate key or keys for the RRH vendor and uplink or downlink. Refer to [“Radio Presets Menu” on page 2-68](#).

Selecting No Preset will maintain the current settings for IQ Bit Width, Reserve Bit and Mapping Method, and Aggregation is set to Off.

5. If the selected preset is Ericsson UL or Ericsson DL, choose between CPRI Aggregation Off or On and set the Reserve Containers as needed. See [Figure 2-80 on page 2-69](#).

You can also select a radio preset by pressing Auto Detect instead of Radio Presets in [Step 3](#). On the CPRI Param Auto-Detect screen, press Radio Preset, then choose the desired preset from the drop-down list.

To manually set the IQ bit width, number of reserve bits, and aggregation condition instead of applying a radio preset, select Custom Settings from the Radio Preset drop-down list, then enter each parameter as appropriate. These parameters are also accessible under the Radio Presets Custom Settings menu for the SFP port being configured.

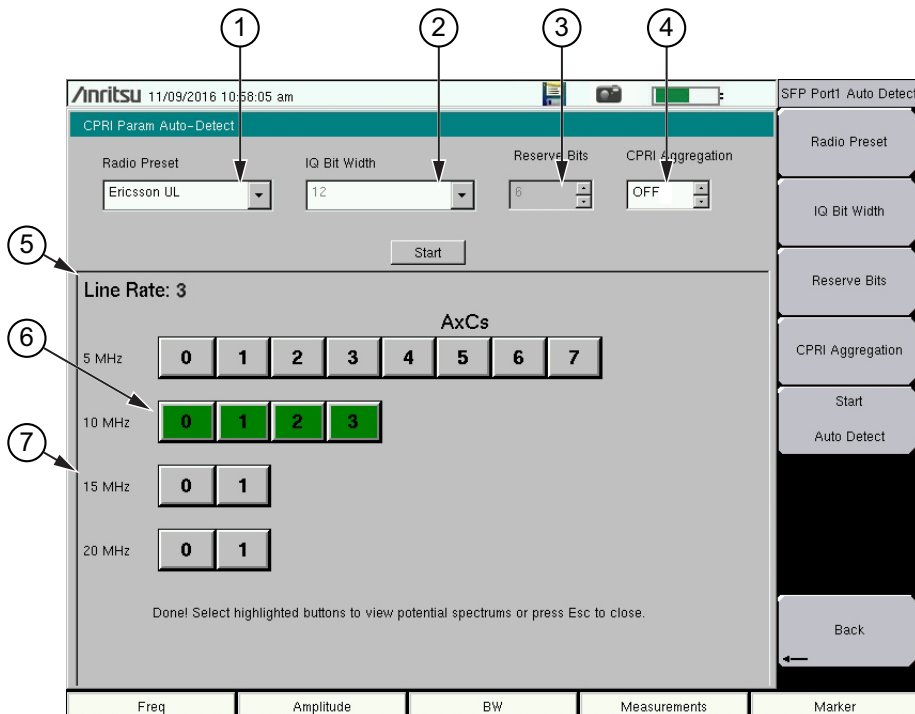
### CPRI Parameter Automatic Detection

Use the Auto Detect feature when you have limited information on the CPRI link to be tested. The test instrument will search for potentially matching signals based on the selected radio preset or the custom settings for IQ bit width, number of reserve bits, and CPRI aggregation on or off.

To start the CPRI automatic detection, select the radio preset or custom settings as described in “Radio Presets”, then press the Start Auto Detect key under the SFP Port1 (or Port2) Auto Detect menu.

The CPRI Analyzer will determine the line rate automatically and highlight in color any available AxC group in the specific carrier bandwidth. See Figure 2-4. More than one button may be highlighted. The results of Auto Detect provide a smaller number of potentially matching signals out of the possible results for a specific line rate. You must check each highlighted button until you find the desired signal.

When you press a highlighted button in the results area, the Auto Detect screen closes, and the signal trace is displayed.



1.	Radio Preset drop-down list (vendor preset or custom settings)
2.	IQ Bit Width (10, 12, 15, or 16)
3.	Reserve Bits (0 to 10)
4.	CPRI Aggregation (Off/On)
5.	Line Rate setting (1 through 8)
6.	Antenna Container Groups
7.	LTE Carrier Bandwidth (5 MHz, 10 MHz, 15 MHz, 20 MHz)

Figure 2-4. CPRI Parameter Auto-Detect Screen

## 2-6 CPRI Measurement Display

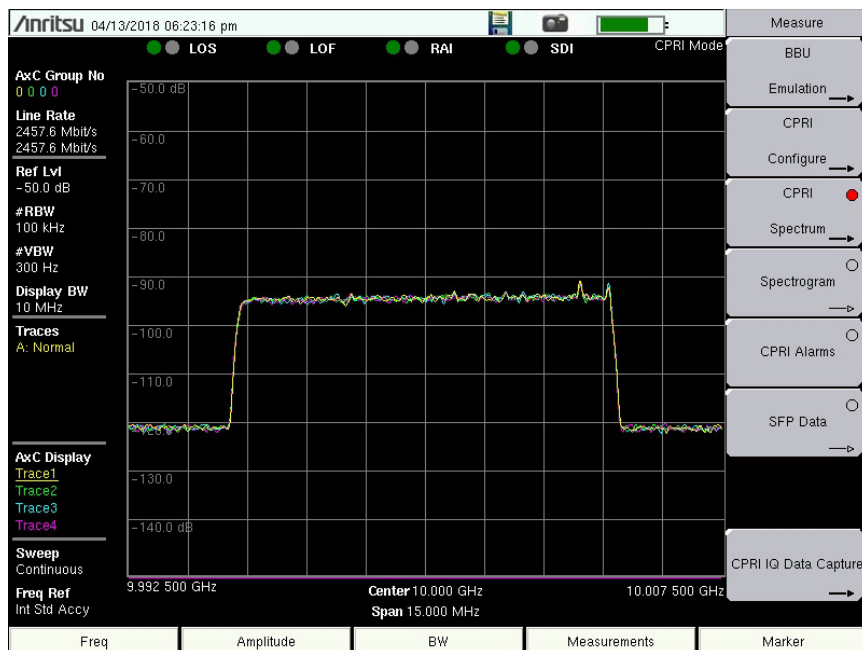
Two measurement display modes are available: spectrum and spectrogram. [Figure 2-5](#) and [Figure 2-6](#) show display screens on an Anritsu BTS Master MT8220T loaded with Option 752. The screens and menus on your instrument may differ depending on the model, installed option, and firmware version.

In both display modes, the connection status of the SFP ports is displayed on the instrument screen as colored dots above the sweep window. Green indicates a good connection, red indicates an error, and gray (no color) means no connection. In the examples below, a dual-port instrument model is shown and Port 2 has no connection.

- LOS – Loss of Signal
- LOF – Loss of Frame
- RAI – Remote Alarm Indication, returned to sender as a response to LOS or LOF
- SDI – SAP (Service Access Point) Defect Indication, when any of LOS, LOF, or RAI is detected

### CPRI Spectrum

Spectrum mode displays signals as a waveform in a traditional spectrum analyzer view.



**Figure 2-5.** CPRI Spectrum Display

- AxC Group No – Shows the AxC group containing the IQ data represented by each of the potential four traces. The AxC group numbers are color-coded to match the display colors of Trace 1 through Trace 4. Use the “[AxC Trace Config Menu](#)” on [page 2-73](#) to manually select the AxC group number for each trace. (This multiple AxC group feature requires firmware version 2.6 or later.)
- Line Rate – Displays the selected line rate for SFP Port 1 (top) and Port 2 (bottom).

- Ref Lvl – Indicates the maximum amplitude value on the Y-axis, that is, the top grid line, of the sweep window. Refer to “[Amplitude Menu](#)” on page 2-51. The value shown is the amplitude reference level of the currently active display: Display 1 or Display 2.
- RBW – Is the current resolution bandwidth. When present, a pound sign (#) in front of RBW indicates that the Auto RBW setting is off and the RBW value is or can be set independently of the frequency span. Refer to “[Bandwidth Menu](#)” on page 2-52.
- VBW – Is the current video bandwidth. When present, a pound sign (#) in front of VBW indicates that the Auto VBW setting is off and the VBW value is or can be set independently of RBW.
- Display BW – Shows the CPRI bandwidth of the currently active display. Refer to “[Display Config Menu](#)” on page 2-72.
- Traces – Displays the Trace A, B, and C Operations settings associated with Trace 1. Refer to “[Trace Menu](#)” on page 2-86. These settings are not displayed when Trace 1 is turned off.
- AxC Display – Lists the traces (1 through 4) that are currently turned on. Refer to “[AxC Trace Config Menu](#)” on page 2-73.
- Sweep – Shows the current sweep mode, single or continuous. Refer to “[Sweep Menu](#)” on page 2-85.

## Spectrogram

A spectrogram is a three-dimensional representation of frequency, time, and power. Color is used to represent the relative power levels.



**Figure 2-6.** CPRI Spectrogram Display

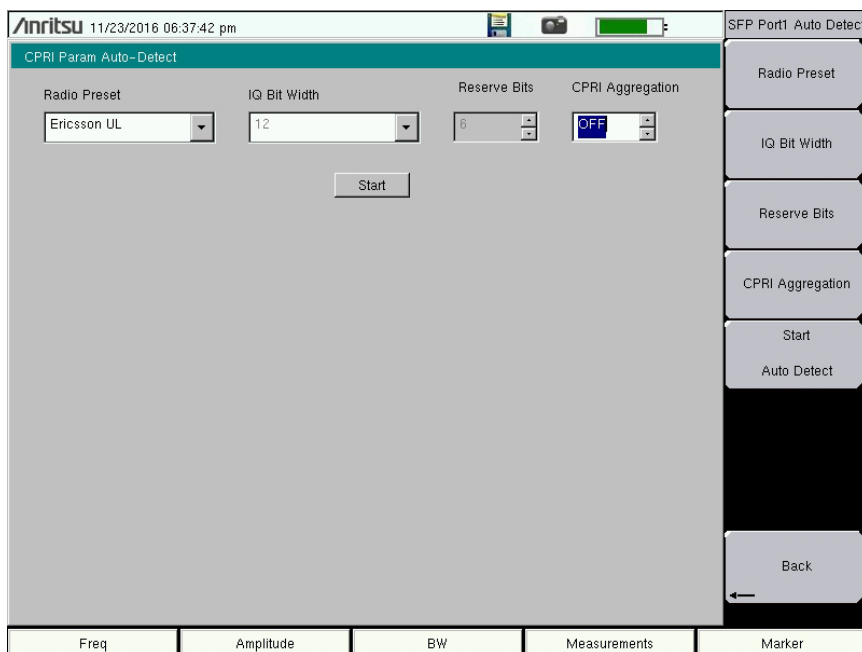
- Sweep Interval – Shows the sweep interval of the currently active trace. Refer to “[Spectrogram Menu](#)” on page 2-75.

- RBW – Is the current resolution bandwidth. When present, a pound sign (#) in front of RBW indicates that the Auto RBW setting is off and the RBW value is or can be set independently of the frequency span. Refer to [“Bandwidth Menu” on page 2-52](#).
- VBW – Is the current video bandwidth. When present, a pound sign (#) in front of VBW indicates that the Auto VBW setting is off and the VBW value is or can be set independently of RBW.
- Traces – Displays the Trace A, B, and C Operations settings associated with Trace 1. Refer to [“Trace Menu” on page 2-86](#). These settings are not displayed when Trace 1 is turned off.
- AxC Trace – Shows the number of the trace being displayed, N/A if no carrier trace is configured, that is, turned on. In dual display mode, a value is displayed for each of Spectrogram Display 1 and 2. When switching from dual to single mode, the currently active display will be shown as the single display. Refer to [“Display Setup Menu” on page 2-76](#).

## 2-7 CPRI Configuration Example

Following is an example of configuring the Anritsu instrument for CPRI testing on the RRH or uplink LTE signal (Port B Out from Port AB on the optical TAP), using one of the available uplink radio presets. The instructions pertain to an Anritsu BTS Master MT8220T loaded with Option 752. Your screen display and user menus may differ depending on your instrument model and firmware version.

1. If your test instrument is not in CPRI measurement mode, press the front panel **Menu** key, then press the CPRI RF application icon.
2. Press the **Measurements** main menu key at the bottom of the touch screen.
3. Press the CPRI Configure menu key.
4. Press SFP Port1 Config or SFP Port2 Config, as appropriate.
5. Press Auto Detect.
6. Press Radio Preset and select the desired radio manufacturer and uplink/downlink type from the drop-down list, then press **Enter**.
7. If the preset is Ericsson, turn the rotary knob to set CPRI aggregation on or off.



**Figure 2-7.** CPRI Parameter Auto-Detect Dialog

8. Press the **Start** button or the **Start Auto Detect** menu key.
9. The line rate is determined automatically. Antenna Carrier (AxC) groups that are available for selection are displayed in color. See [Figure 2-8](#).

10. Press one of the highlighted AxC groups.

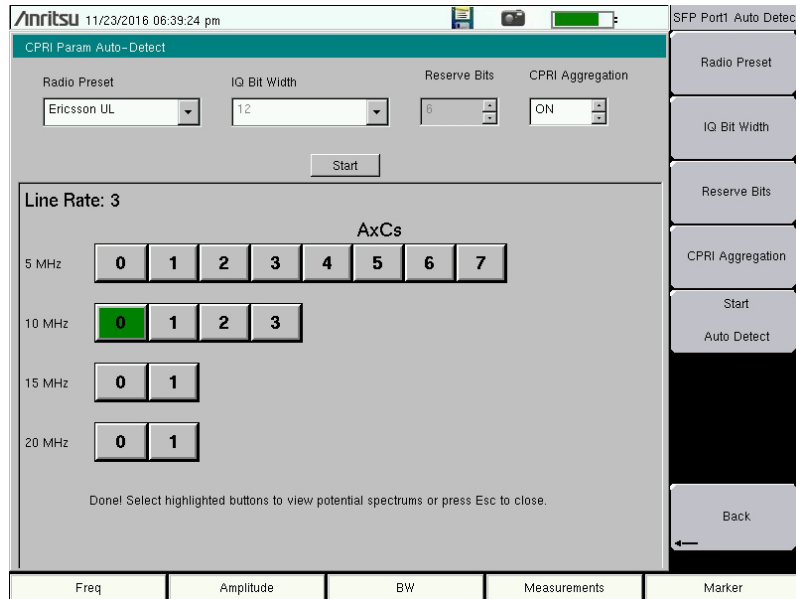


Figure 2-8. Line Rate and Available AxC Groups

11. A Spectrum view similar to Figure 2-9 is displayed.

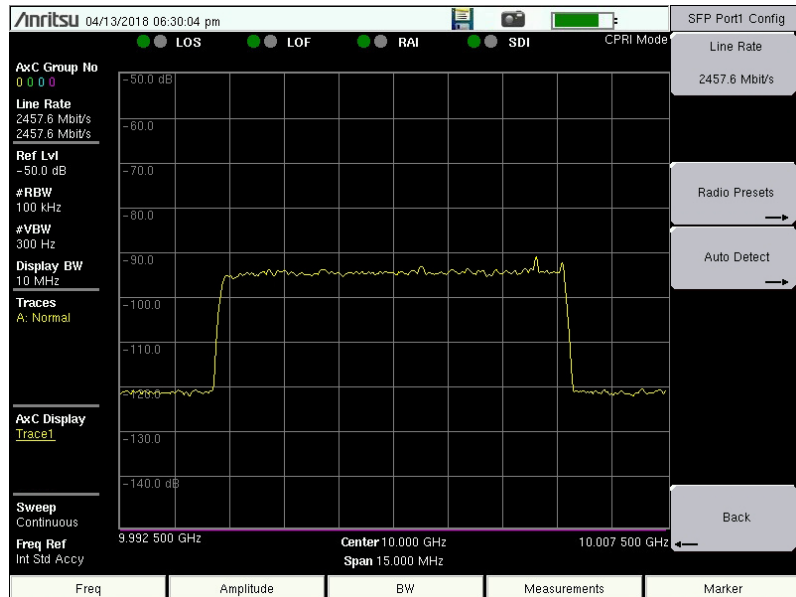


Figure 2-9. Sample Spectrum Display

12. To change the view to spectrogram, press the **Measurements** key, then Spectrogram. Refer to the Spectrum Analyzer Measurement Guide for details on Spectrum Analyzer and Interference Analyzer (Spectrogram) functions.

## 2-8 Base Band Unit Emulation (Option 760)

The Base Band Unit Emulation feature in the CPRI LTE RF application is available with Option 760. It provides RRH test functionalities through the CPRI measurement interface, allowing you to test the RRH connectivity before the BBU is actually installed.

<b>Note</b>	Option 760 requires CPRI LTE RF Analyzer Option 752 and may not be supported on all instrument models. Refer to your instrument's Technical Data Sheet for option availability.
-------------	---

You can send an LTE waveform pattern and have the RRH transmit it over the air, thereby verifying the transmit functionality. LTE waveforms are available for different bandwidths: 5 MHz, 10 MHz, 15 MHz, and 20 MHz.

The BBU LTE RF test performs RRH-based measurements and displays the results for Return Loss (RL) and Voltage Standing Wave Ratio (VSWR). Return Loss measures the reflected power of the system in decibels (dB). VSWR is the ratio of voltage peaks to voltage valleys caused by reflections. You can set the return loss limit and VSWR limit to detect any transmission problem between the instrument, RRH, and antenna system.

Prior to running BBU tests, you must select and initialize the RRH. BBU scripts are included with Option 760 and are specific to an RRH model. They contain commands required to perform actions such as RRH initialization or to get VSWR or SFP data. If necessary, you can reload the scripts or download new scripts from an external USB device to the Anritsu instrument's internal memory, as described in "[BBU Script Download](#)".

<b>Note</b>	For accurate measurements, be sure to either attain a GPS location fix for your instrument or select an external frequency reference before entering BBU Emulation Mode.
-------------	--

### Remote Electrical Tilt Device Test (Option 761)

Many RRHs have integrated Remote Electrical Tilt (RET) controllers, allowing operators to monitor and remotely make adjustments to the tilt angle of antennas. Option 761 adds RET device test capabilities to the BBU Emulation functions of Option 760. Without Option 761 installed and activated, you can still perform a scan of the CPRI links and view the status of any connected RET devices.

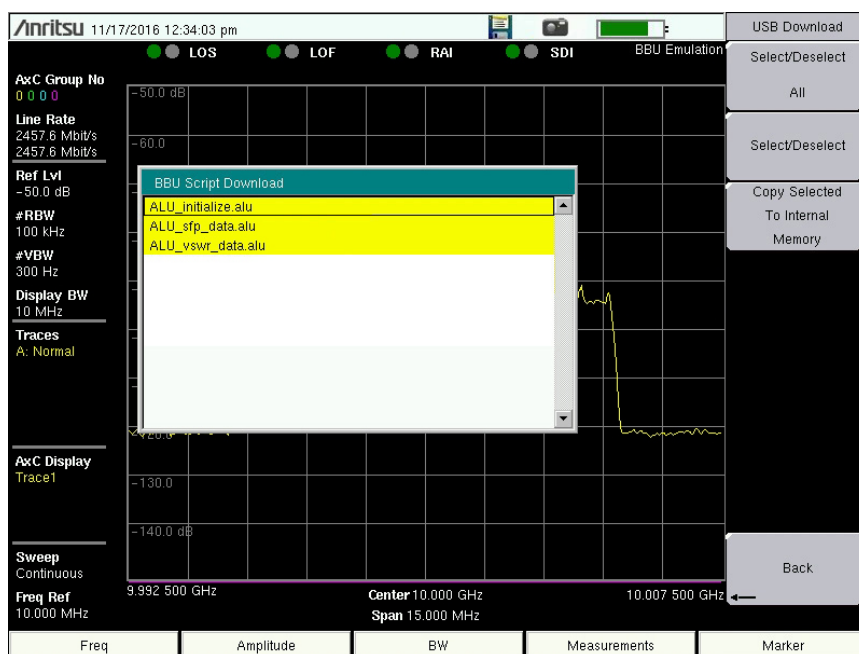
Option 761 provides a communications interface to the RET device via the RRH over a CPRI link. The device type can be Single Antenna, Multi-Antenna, eAntenna, or Tower-Mounted Amplifier (TMA).

The Anritsu test instrument scans for RET devices connected to the RRH and will report on device status and alarms. You can also calibrate and set up an RET device, query its status, and generate reports listing the current configuration of all the devices.

## BBU Script Download

Script files are included with the Option 760 firmware. Follow this procedure only if you have custom scripts that you want to download to the Anritsu test instrument. The script folder must be named `aluscripts` and reside in a directory named `BBUEmulationScripts` on a USB storage device.

1. Insert the USB device containing the script files into the test instrument USB port.
2. With the instrument running in CPRI Mode, press the **Measurements** main menu key at the bottom of the touch screen, then press BBU Emulation.
3. Press Script Manager followed by USB Download. An error message is displayed if no USB device is connected or no BBU script folder is found, with the correct name and directory structure. Refer to “[Script Manager Menu](#)” on page 2-56.
4. Select the scripts from the list and press Copy Selected To Internal Memory.



**Figure 2-10.** BBU Scripts Download Screen

5. Press Back to return to the BBU Emulation menu.

## LTE Waveform Download

As with BBU scripts, LTE waveforms are provided with Option 760. Skip this section unless you need to download your own LTE waveforms to the Anritsu test instrument. The waveform folder must be named `AN_LTE_Waveforms` and reside in the root directory of a USB storage device. Files must be contained in subfolders named for the bandwidths: 5MHz, 10MHz, 15MHz, and 20MHz.

1. Insert the USB device containing the waveform files into the test instrument USB port.
2. With the instrument running in CPRI Mode, press **Measurements**, then BBU Emulation.

## 3. Press Waveform USB Download.

An error message is displayed if no USB device is connected or no properly named waveform directory is found.

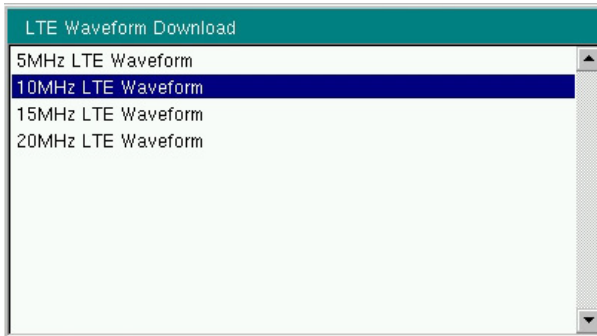
4. Select a bandwidth from the list, then press **Enter**.

Figure 2-11. LTE Waveform Bandwidth List

## 5. Scroll through the list associated with the chosen bandwidth and press Select/Deselect to highlight waveforms, then press Copy Selected To Internal Memory.

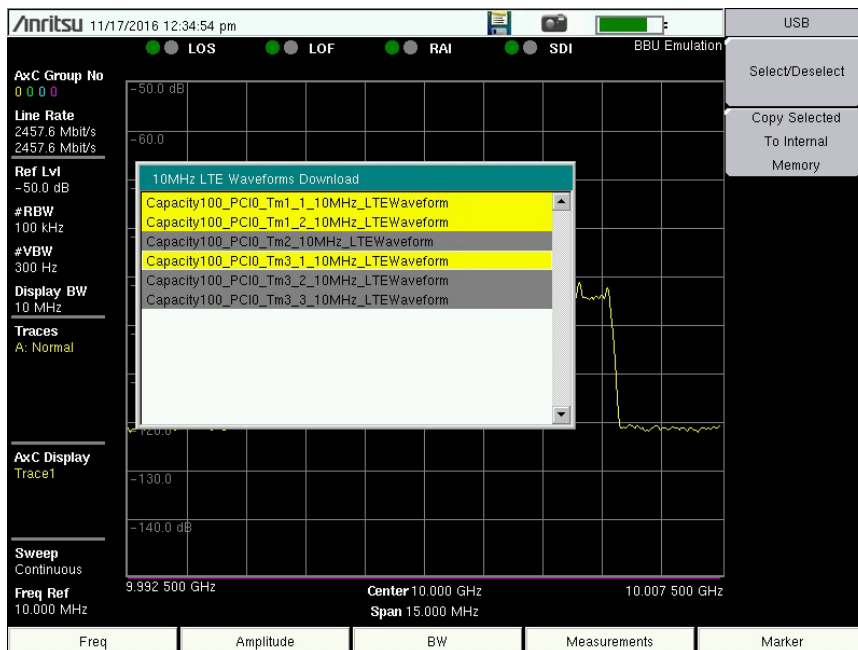


Figure 2-12. LTE Waveforms Download

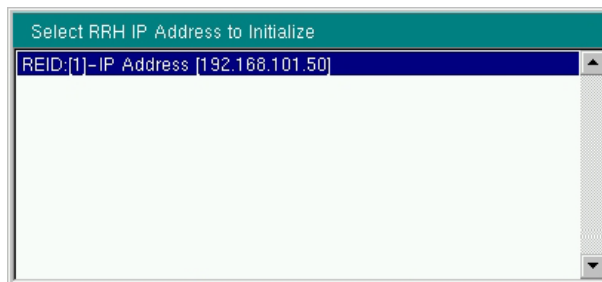
6. Repeat [Step 3](#) through [Step 5](#) as needed to download waveforms of different bandwidths.

## BBU Test

To run a BBU test, follow the steps described below. It is assumed that any needed scripts such as BBU scripts and LTE waveform patterns have been downloaded to the Anritsu instrument internal memory, as described in the previous sections.

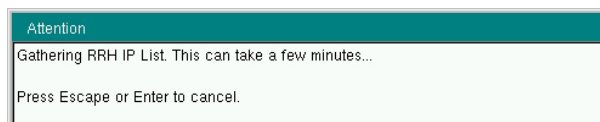
1. For accurate measurements, select an external frequency reference or establish a GPS location fix for your instrument *before* entering BBU Emulation mode.
2. Follow instructions in the “[CPRI Configuration Example](#)” on page 2-12 to set up the Anritsu instrument for the RRH you plan to test.
3. From the CPRI mode Measure menu, press BBU Emulation. The Anritsu instrument’s SFP port will go from slave to master mode.
4. If not connected, connect the instrument SFP to the RRH slave port using a suitable fiber cable.
5. Press Select Initialize RRH to start auto-negotiating the line rate with the RRH and establish a CPRI connection to the passive layer.

If multiple radios are connected in a daisy chain, the Anritsu instrument assigns an IP address to each, using its built-in DHCP server. It may take a few minutes for the instrument to gather RRH IP information, then a pop-up window is displayed, listing the RRHs that responded.



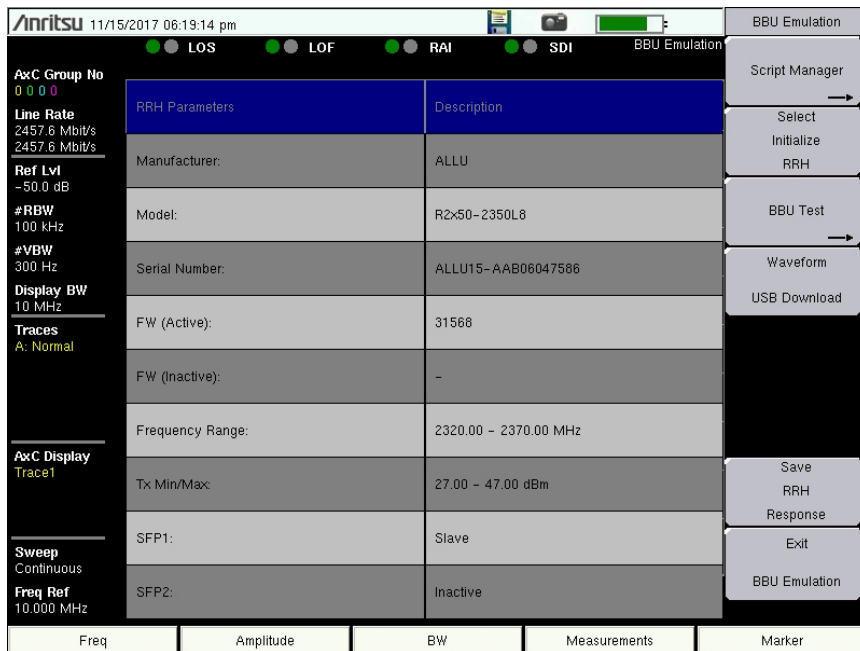
**Figure 2-13.** RRH IP Address List

6. Choose the desired IP address from the displayed list, then press **Enter**.
7. A message box is displayed while information on the selected RRH is collected.



**Figure 2-14.** Attention Message Box

8. Review the displayed RRH parameters as needed.



**Figure 2-15.** RRH Parameter Display

9. Press BBU Test. Note that this key is active only after you have initialized the RRH in the preceding steps.
10. Optionally, press RRH SFP Data and the appropriate submenu key to view information on the RRH SFP. See [Figure 2-66](#) and [Figure 2-67 on page 2-59](#). Press Back to return to the BBU Test menu.
11. To remotely monitor and control RET devices through the RRH, proceed with “[RET Test](#)”.  
To perform RRH-based measurements, skip to “[BBU RF Test](#)”.

## RET Test

The following instructions assume that you have loaded any necessary scripts and successfully connected to an RRH as described in the previous sections. Refer to “RET Test Menu” on page 2-60 for a description of individual menu keys.

**Note** Option 761 is required to perform RET Test. Without the option installed and activated, you can only scan for and update the status of connected devices.

1. Press RET Test under the BBU Test menu.

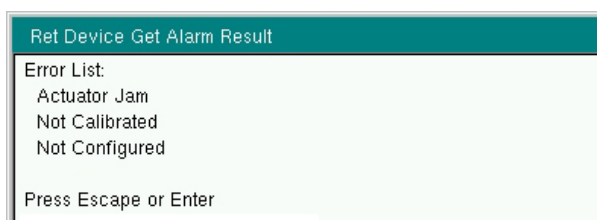
The instrument automatically scans for all RET devices connected to the selected RRH, then displays their current status on the instrument screen. See [Figure 2-16](#).

If no RET devices are found, a “No Devices Detected” message will display. You can optionally press the Device Update key to perform another scan.



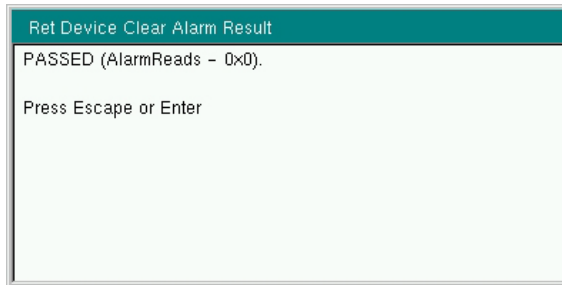
**Figure 2-16.** Available RET Devices

2. If all detected devices show “Pass,” skip to [Step 5](#). If a device displays a “Fail” status, use the **Up/Down** arrow keys, rotary knob or the touch screen to highlight, that is, to select it, then press **Get Alarms**. Only one device can be selected at any time.



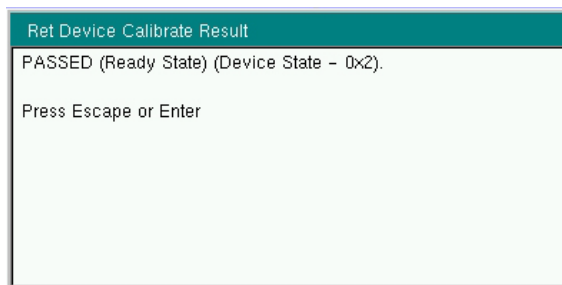
**Figure 2-17.** Get Alarm Results

3. Press **Clear Alarms** to attempt and clear the error(s). A message will display, indicating whether the attempt was successful.



**Figure 2-18.** Clear Alarm Results

4. If alarms remain after the clearing attempt, take the necessary corrective actions. You can also initiate a self-test on the selected device by pressing the **Self Test** key.
5. If needed, select a RET device, then press **Calibrate** to make the actuator move through its entire tilt range, thus determining the minimum and maximum electrical tilts. A calibration result window will display when the action is completed.



**Figure 2-19.** Device Calibration Results

6. Press **Configure Device** to display the configuration form. Some fields are pre-populated with the current configuration settings of the RET device. See [Figure 2-20](#).
7. Proceed through the next steps only if you need to make configuration changes. Otherwise, press **Exit** to return to the RET Test menu, then skip to [Step 14](#).

To edit a configuration field, use the touch screen, rotary knob, or **Up/Down** arrow keys to highlight it, then press the appropriate keys to change the value. Some of the fields are read-only.

**Note**

The menu keys change depending on the data type of the current configuration field. Text entry methods are also different for instrument models with and without a touch screen.

Press **Save Configuration** to save current settings to the RET device. Saved settings will appear in configuration reports generated during this RET Test session. Fields marked with an asterisk (\*) in the Device Configuration dialog are saved to the test instrument internal memory but cannot be permanently saved to the RET device, and are cleared when you exit RET Test mode.

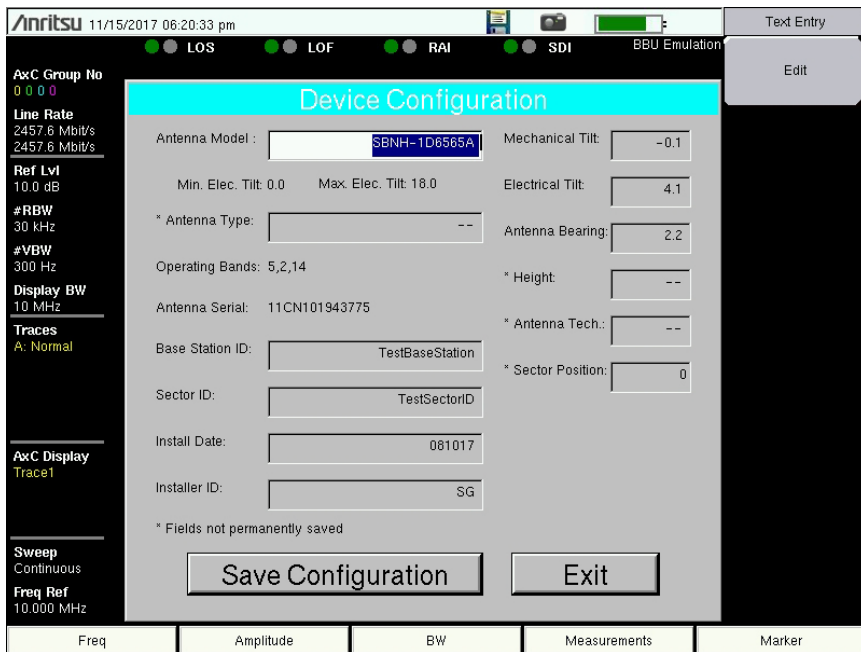


Figure 2-20. RET Device Configuration Dialog

8. To enter the antenna model in the associated field, press Edit in the screen illustrated above. A virtual keyboard is displayed if your instrument model has a touch screen. See [Figure 2-21](#).

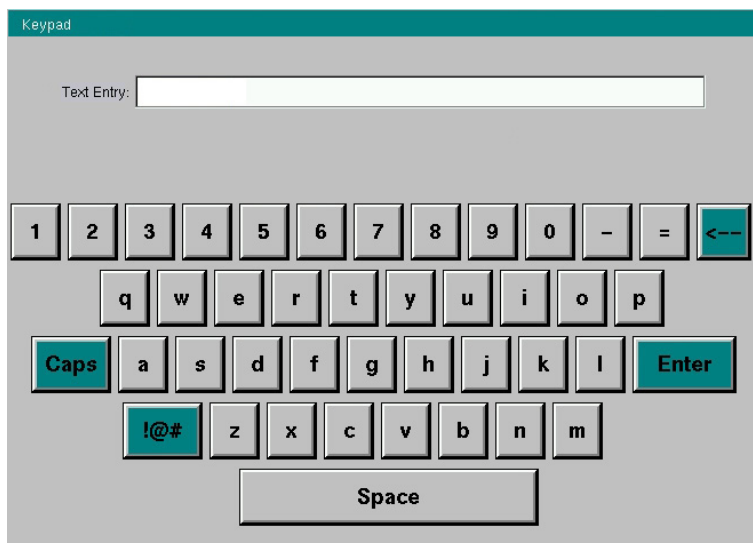


Figure 2-21. Virtual Keyboard (instrument models with touch screen)

If your Anritsu test instrument is not a touch screen model, use the soft keys illustrated in [Figure 2-22](#) to enter text, and follow the on-screen instructions to move the cursor.



Figure 2-22. Text Entry Menu (instrument models with no touch screen)

9. Select the Antenna Type either by pressing the Edit key to type in the text field or by pressing Quick Entry to select from a menu. See [Figure 2-23](#) and [Figure 2-24](#).

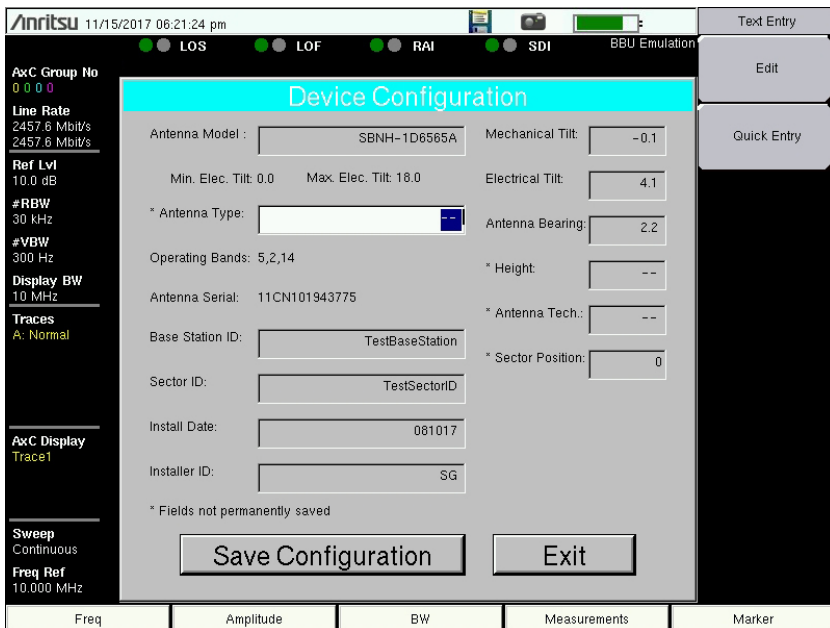


Figure 2-23. Antenna Type Selection

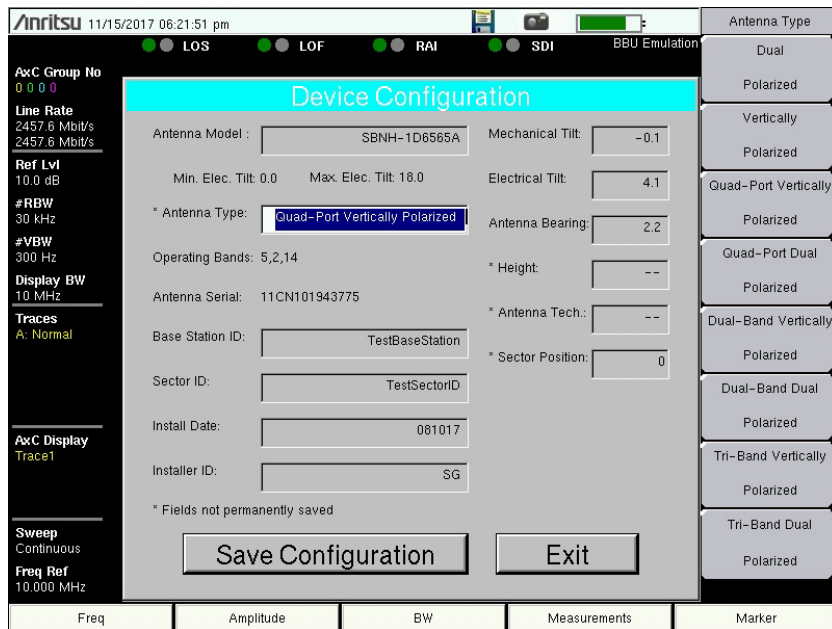


Figure 2-24. Antenna Type Quick Entry Menu

10. Configure other text fields in the same manner, using the Edit key or Quick Entry if present. For numeric fields, use the numeric keypad, then press Enter. The Antenna Height value is in meters. The Sector Position value ranges from 0 to 255.
11. To adjust the antenna tilt angle, select the field and use the numeric keypad to enter a new value for the Electrical Tilt. The value must be within the valid tilt range (minimum and maximum). Press Enter to submit the new value.



Figure 2-25. Electrical Tilt Entry

12. Edit the remaining fields as needed, then press **Save Configuration**. The saved values will be listed in configuration reports that you generate during this RET Test session. Newly entered settings are lost if you exit the Device Configuration dialog before saving.

Fields marked with an asterisk (\*) are saved to the test instrument internal memory but cannot be permanently saved to the RET device. These fields are cleared when you exit RET Test mode:

**Note** Antenna Type  
Tower Height  
Antenna Technology  
Sector Position

13. Press **Exit** to close the Device Configuration dialog and return to the RET Test menu. The Available RET Devices window will display the updated device status.
14. To output the current configurations of all detected RET devices to a text file, press the **Generate Report** key. The report file will be named with the current date and time and saved to the instrument's internal memory.



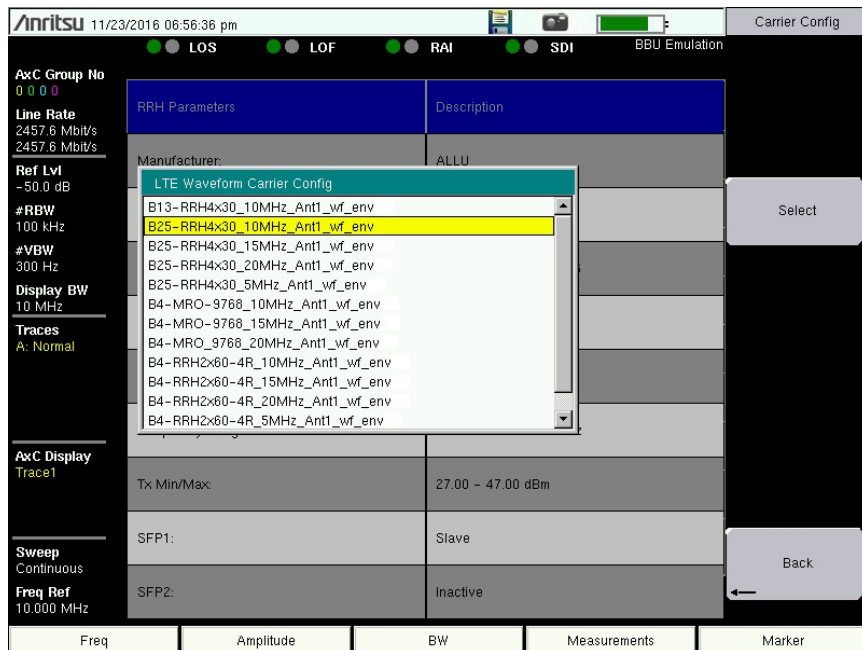
**Figure 2-26.** Report Generation State

15. Press **Back** to return to the BBU Test menu.

## BBU RF Test

The following procedure assumes that you have loaded any necessary scripts and successfully connected to an RRH as described in the previous sections.

1. Press BBU RF Test under the BBU Test menu.
2. Press LTE Waveforms.
3. Press Select Radio Type and choose from the list the carrier configuration that matches the radio type and bandwidth of the signal you want to transmit through the RRH. Press Select.



**Figure 2-27.** LTE Waveform Carrier Configuration

4. Optionally, press the Center Frequency key under the LTE Waveforms menu and adjust the carrier frequency of the radio. The frequency defaults to the center frequency of the selected RRH transmit band.
5. You may also adjust the transmit power from the RRH using the Output Power key. The default power is 3 dB below the maximum output power of the RRH being tested.
6. Press Apply Changes to update the RRH configuration.

7. Press **Select Waveform** and select a bandwidth from the list, then press **Enter**.

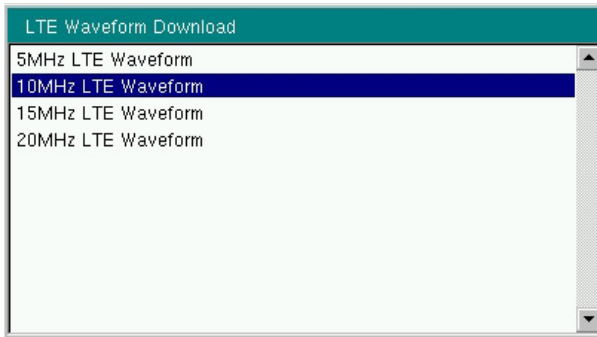


Figure 2-28. LTE Waveform Bandwidth List

8. Scroll to the waveform corresponding to the radio type selected earlier, then press **Select/Deselect** to highlight it. One waveform pattern may be transmitted at a time.

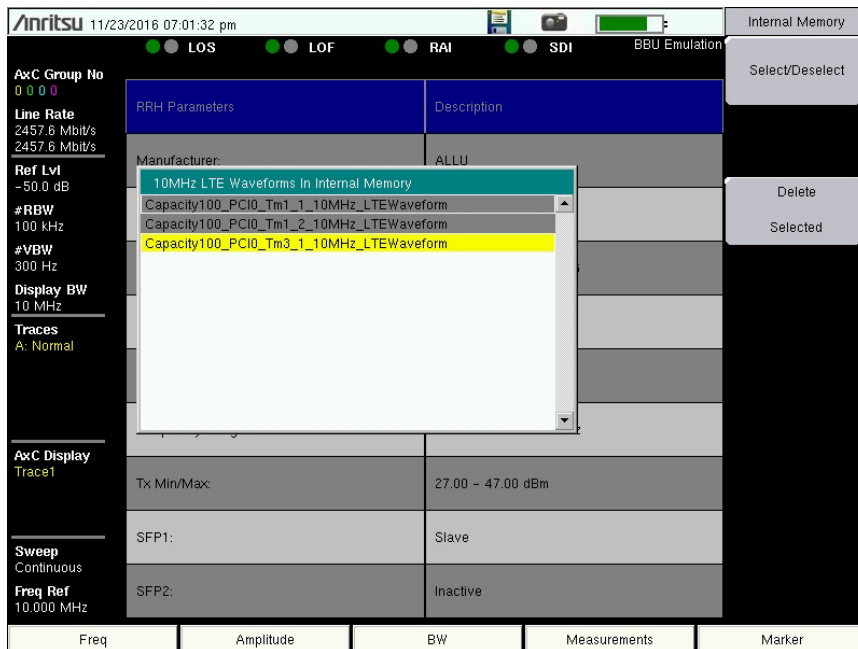


Figure 2-29. LTE Waveform Select

9. Press the **Enter** key to load the selected waveform.
10. Wait for the message indicating that loading was successful, at which point the **Play Waveform** key on the LTE Waveforms menu will become active.

11. Press Play Waveform to turn on the transmitter and send the waveform to the RRH.

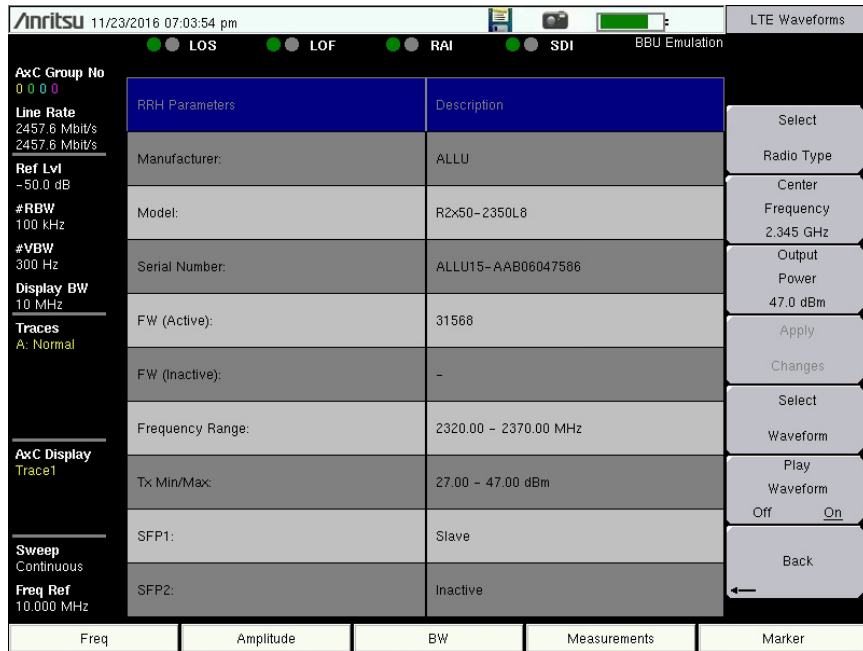


Figure 2-30. Play Waveform

12. Stand in front of the desired antenna with a spectrum analyzer and you should see the waveform transmitting from the antenna.

13. Press Back to return to the BBU RF Test menu, then press Return Loss/VSWR.  
 Provided the RRRH is transmitting, test results are displayed on the instrument screen.

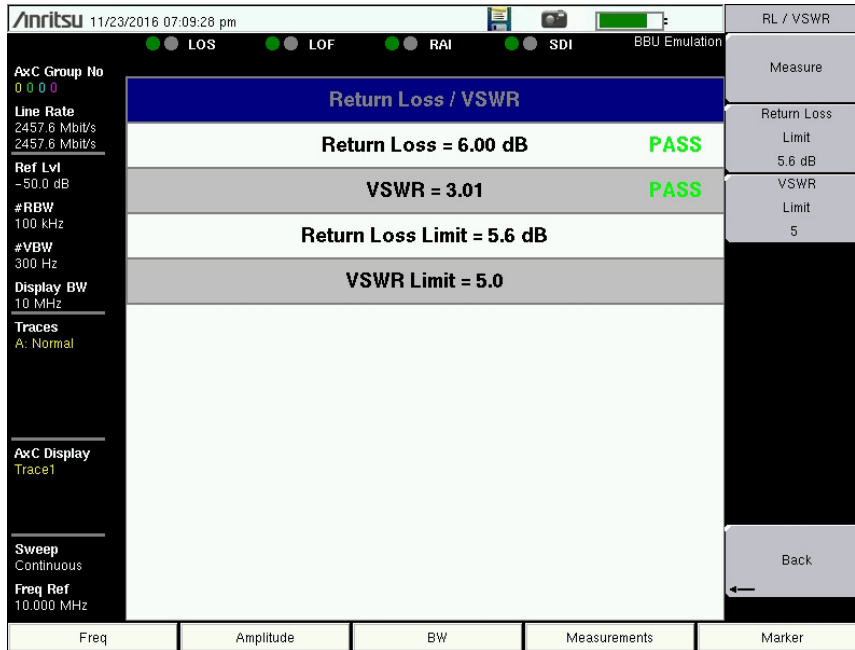


Figure 2-31. Return Loss/VSWR Measurement Results

14. You can optionally change the return loss limit and VSWR limit and press Measure to run the test again.

## 2-9 PIM Over CPRI (Option 754)

The PIM over CPRI feature in the CPRI LTE RF application is available with Option 754. It allows your Anritsu test instrument to detect and measure interference from Passive Intermodulation (PIM) on LTE signal carriers. Measurements are made via a CPRI connection over optical fiber, using live traffic data. This is in contrast to other PIM measurement solutions that use RF tones to create PIM in the RF network under test, which may be in violation of local regulations restricting the transmission of test tones on a live network.

**Note** Option 754 is not supported on all instrument models. It requires Option 752, CPRI LTE RF Analyzer, and Option 759, RF over Fiber Hardware (dual SFP ports). Refer to your instrument's Technical Data Sheet for option availability.

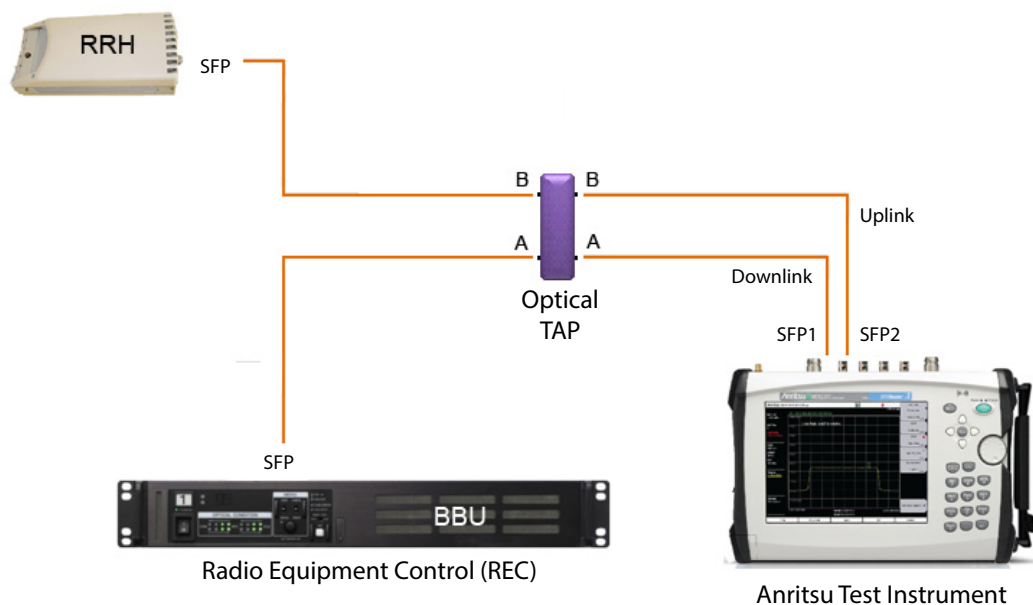
By inserting optical taps between the BBU and RRH for the uplink and downlink carriers, you can measure PIM without the need to take the system out of service. This eliminates the potential for PIM that might result if it were necessary to reset RF connections.

Unlike traditional RF PIM analyzers, which must be taken to the top of cell towers or close to the antenna to run measurements, Anritsu's PIM over CPRI software option enables true PIM measurements from ground level, increasing site safety while speeding up network performance validation.

Figure 2-32 and Figure 2-33 illustrate examples of CPRI link connections to an Anritsu test instrument in the following PIM cases:

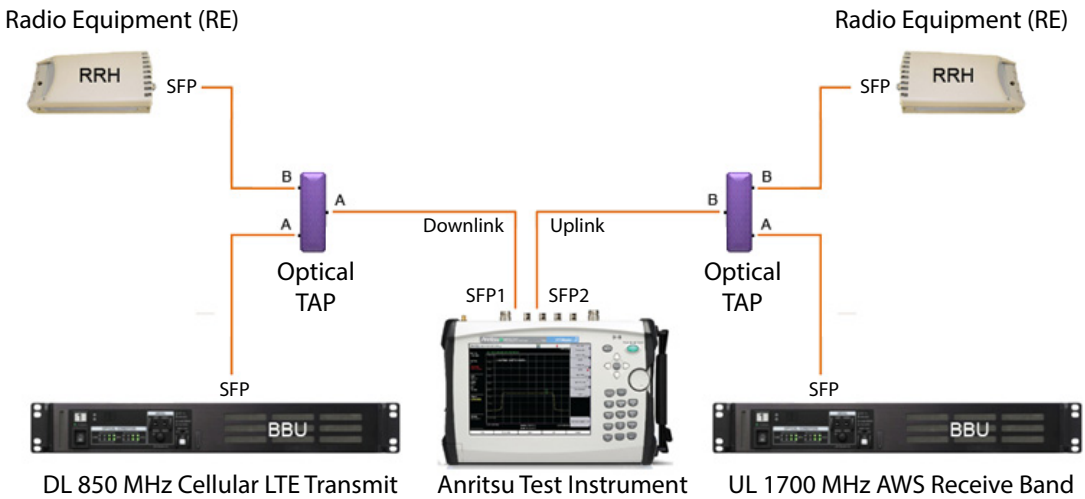
- Single carrier 2x2 MIMO LTE interfering with its own uplink (self-PIM interference) – An example may be a 10 MHz LTE carrier downlink centered at 751 MHz with 7th order intermodulations that fall in the 782 MHz uplink band.

Radio Equipment (RE)



**Figure 2-32.** Self-PIM Interference Test Instrument Connection

- Single carrier 2nd order intermodulation (2nd harmonic) – Examples may be a an 850 MHz cellular transmitter's 2nd harmonic landing in the 1700 MHz AWS receive band, or an 860 MHz cellular transmitter's harmonic falling in a 1720 MHz AWS uplink band.



**Figure 2-33.** 2nd Harmonic Test Instrument Connection

## PIM Over CPRI Configuration Settings

Before starting the PIM measurement, choose the appropriate settings in each of the following configuration categories:

- Site configuration
- PIM desensitization limit
- Downlink configuration
- Uplink configuration
- Uplink under test

### Note

These parameters are set in the PIM Aid configuration dialog. See [Figure 2-34](#). When saved, the selections made here override any conflicting settings previously chosen in the CPRI configuration, such as line rate, display bandwidth, and uplink AxC group and SFP port associations.

### Site Configuration

Anritsu's PIM over CPRI feature supports analysis of up to four simultaneous CPRI streams.

- SISO – Single downlink, single uplink
- 2x2 MIMO – 2 downlinks, 2 uplinks
- 2x4 MIMO – 2 downlinks, 4 uplinks

The CPRI downlink is connected to the Anritsu test instrument's SFP Port 1. The uplink is connected to SFP Port 2.

**Figure 2-34.** PIM Aid Dialog

### PIM Desensitization Limit

This is the user-selectable threshold for acceptable noise floor degradation, in dB. A measurement that exceeds the set limit will result in a Fail status and trigger the alarm.

### Frequency

The Frequency fields for downlink and uplink accept numeric values and are edited using the instrument keypad. The values entered are in MHz.

### LTE Bandwidth

The downlink and uplink LTE bandwidths are selectable from a menu of four supported LTE carrier bandwidths: 5 MHz, 10 MHz, 15 MHz, and 20 MHz. The applied uplink bandwidth will display on the left side of the trace window.

### AxC Group

Use the AxC fields to associate an AxC group number with each downlink and uplink trace. The number of configurable traces depends on the selected site configuration.

### Line Rate

The Line Rate buttons in the Downlink and Uplink sections of the PIM Aid dialog show the respective line rates currently selected. The buttons also function as Auto Detect keys and will display the actual downlink or uplink line rates anytime they are pressed.

When applied, the downlink (SFP Port 1) and uplink (SFP Port 2) line rates are displayed on the left side of the instrument screen.

**Radio Preset**

Radio presets are currently available for ALu/Nokia.

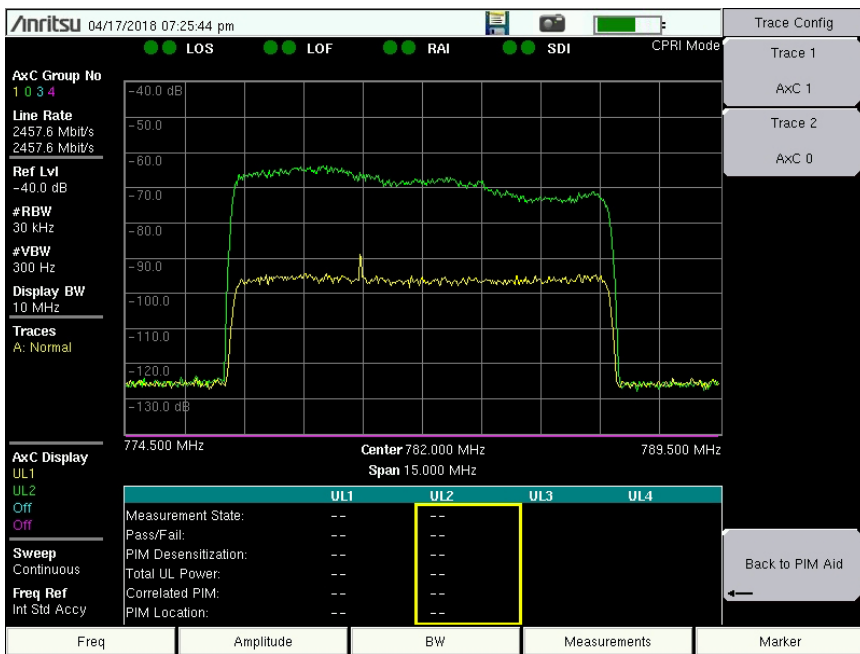
**View Downlink/Uplink Configuration**

Press the View DL Configuration or View UL Configuration button to apply the current settings and display the downlink or uplink traces, respectively. The PIM Aid dialog will close without exiting Configuration mode.

The number of traces displayed is determined by the chosen site configuration. For example, one trace is displayed if the configuration is SISO, and two downlinks or four uplinks in 2x4 MIMO. [Figure 2-35](#) illustrates two uplink traces in 2x2 MIMO.

To change the AxC group number for a trace, press the desired Trace number key under the Trace Config menu and edit the AxC group.

Press the Back to PIM Aid key to return to the configuration dialog.



**Figure 2-35.** View Uplink Configuration Example

**Uplink Under Test**

During PIM measurements, the Anritsu test instrument displays only the Uplink Under Test and the Correlated PIM as Trace 3 and Trace 4, respectively. Trace 1 and Trace 2 are off.

In 2x2 and 2x4 MIMO, you can elect to cycle through all uplinks or measure only one uplink. Choosing Cycle through All ULs will measure all available uplinks one at a time. To measure a single uplink, press the UL radio button (see [Figure 2-36](#)), then the UL number box to display the UL Under Test menu, and press the desired uplink number.

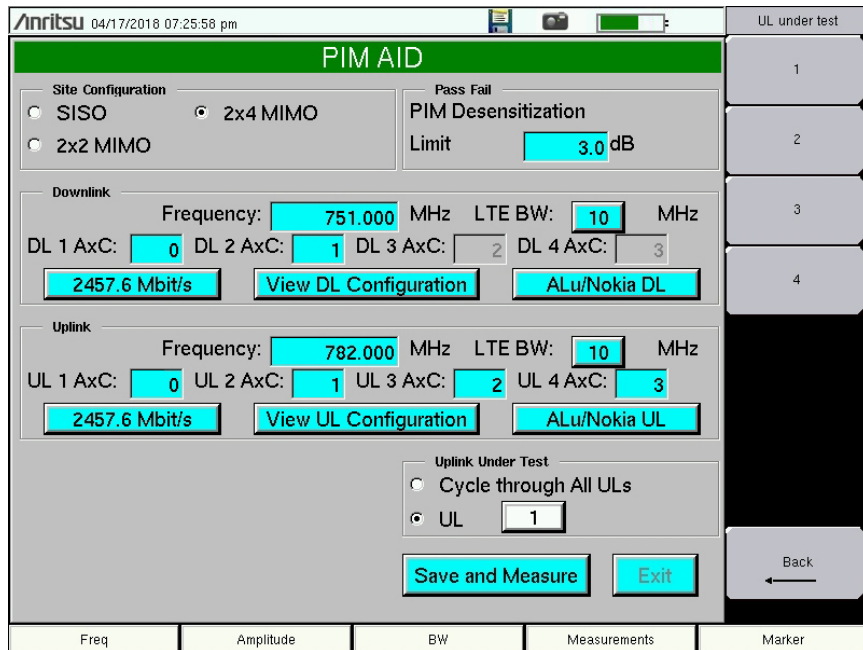



Figure 2-36. Select Uplink Under Test

**Save and Measure**

To save the current configuration settings and start PIM over CPRI measurements, press the Save and Measure button.

**Exit**

Press the Exit button or the instrument panel **Esc** key to close the PIM Aid dialog without making changes.

<p><b>Important</b></p> 	<p>The Exit button is active only if you have not made a change in the PIM Aid dialog. The button is disabled (grayed out) if you have modified one of the configuration fields. For all configuration settings to be applied properly to the PIM over CPRI measurements, use the Save and Measure button.</p>
---	--

### PIM Configuration and Measurement Procedure

To set up the PIM over CPRI measurement and start the test:

1. Make sure the instrument is in CPRI Mode, then press the **Measurements** key.
2. Press PIM Over CPRI.
3. Press PIM Aid to open the configuration dialog illustrated in [Figure 2-34](#).
4. Make the appropriate entries and selections.
5. When done, press **Save and Measure** to close the PIM Aid dialog and save the new settings. This action also starts the PIM measurement. The configuration window will close and a summary table of measurement results will display, with the Uplink Under Test and Correlated PIM traces.

**Note** For best results, it is highly recommended to maximize the downlink transmit power to emulate a worst-case scenario where unwanted PIM levels are at a maximum. With Nokia/ALu equipment, for example, set OCNS to turn on maximum power for all resource blocks.

The first measurement for each Uplink Under Test may take approximately 55 seconds to acquire data, synchronize the downlink carrier or carriers to the individual uplink carrier under test, and perform the measurement. See [Figure 2-37](#).



**Figure 2-37.** PIM Over CPRI Data Acquisition

After the initial acquisition and measurement cycle completes, subsequent measurements for each Uplink Under Test will take approximately 6 seconds. [Figure 2-38](#) and [Figure 2-39](#) show examples of the PIM over CPRI spectrum display and results table in 2x2 MIMO. For a description of each row item, refer to “[Results Table](#)” on page 2-36.

Trace 3 (in blue) is the latest uplink where testing has completed, and the corresponding measurement results are highlighted with a yellow border. Trace 4 (purple) is the Correlated PIM. Trace 1 and Trace 2 are always off during PIM over CPRI testing.

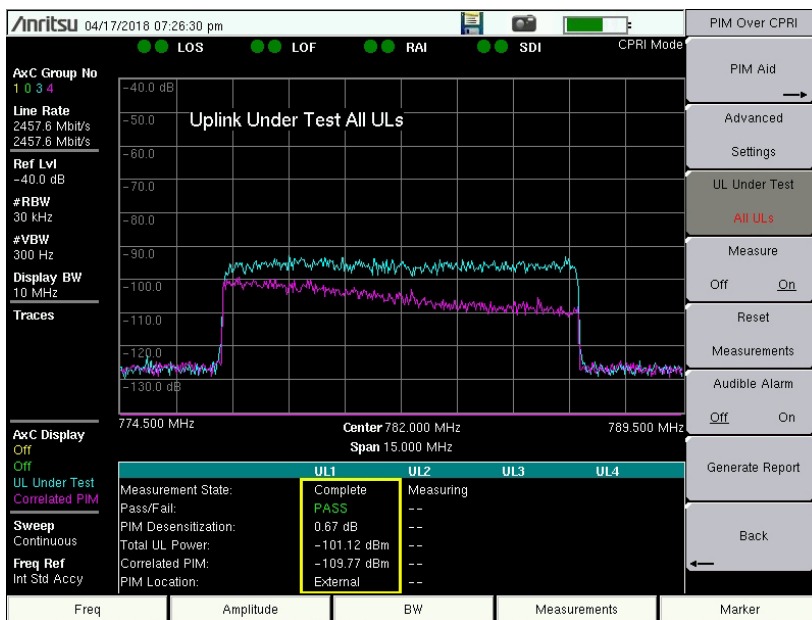


Figure 2-38. PIM Over CPRI Measurement Display – UL1 Pass

If the Uplink Under Test setting has been configured to cycle through all uplinks, the next uplink to be tested will display as Trace 3 when measurements are completed, and the yellow highlight border in the results table will shift to the appropriate UL number.

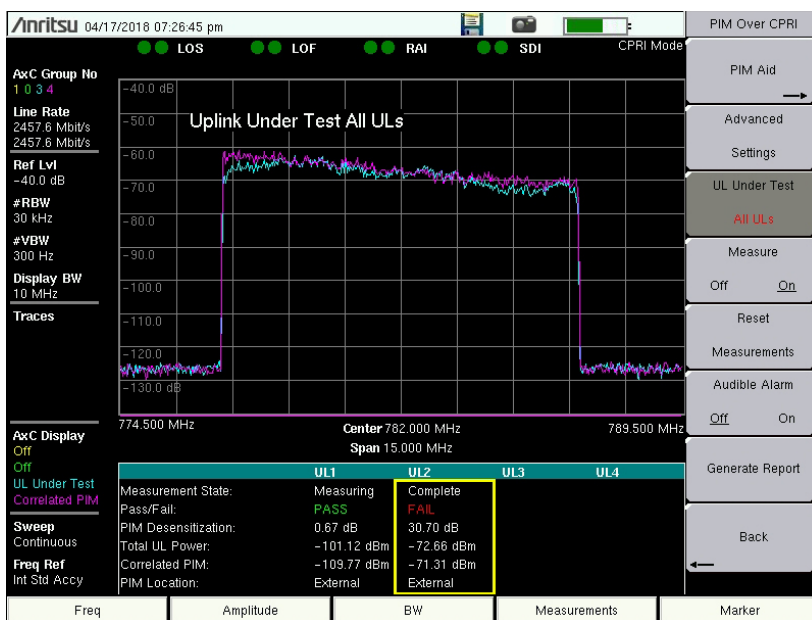


Figure 2-39. PIM Over CPRI Measurement Display – UL2 Fail

To stop the measurement and view the most recent results without the data continually updating, press the **Measure** key to turn it off. Data for each Uplink Under Test will be re-acquired and measurements will restart with the current configuration settings when you press **Measure On**.

## Results Table

The results table is empty if you have not yet run PIM over CPRI measurements or you have performed a reset (refer to “[Reset Measurements](#)”). The table will populate with data as measurement completes for each Uplink Under Test. The most recent uplink to complete measurement is highlighted with a yellow border.

Data from previous measurements remain in the results table until they are updated with new measurements or cleared with the **Reset Measurements** key.

## Measurement State

This field indicates the current stage in the uplink’s PIM over CPRI measurement cycle.

- **Acquiring** – The PIM over CPRI engine is acquiring data and synchronizing the downlinks and uplinks.
- **Measuring** – PIM over CPRI measurement is being performed on the uplink.
- **Complete** – Measurement has completed for the uplink and results are displayed in the table.
- **Switching UL** – The PIM over CPRI engine is finishing the operation currently in progress before starting acquisition or measurement on the uplink newly selected with the **UL Under Test** menu key.
- **Idle** – The measurement is running but cannot complete, possibly due to error conditions like insufficient transmit power, or incorrect configuration settings such as AxC group or radio manufacturer. Verify the current settings in the **PIM Aid** window and make changes as necessary, then press **Save and Measure**.
- **CPRI FAIL** – An error occurred on the CPRI link, as indicated by any of the SFP port connection status dots at the top of the display being red or gray, and not green. In the event of a CPRI link failure, the measurement will turn off and must be manually restarted. The new measurement will start with a new acquisition cycle.

## Pass/Fail

The measurement Pass/Fail status is based on the acceptable noise floor degradation level specified as the **PIM Desensitization Limit** configuration setting.

## PIM Desensitization

This is the calculated rise in noise floor level that can be attributed to PIM on the uplink contributed by the downlinks being analyzed.

## Total UL Power

This is the measured uplink signal strength. The displayed value can be converted from dBm to dBFS and back via the **Advanced Settings** dialog (see [Figure 2-96 on page 2-81](#)).

**Correlated PIM**

This is the expected PIM contribution from all downlinks that is found to correlate with the Uplink Under Test.

**PIM Location**

This field indicates the location of the PIM source, internal or external.

**Reset Measurements**

Pressing the **Reset Measurements** key under the PIM Over CPRI menu will stop the current measurements if a test is running, and clear all uplink data from the results table. The configuration settings that were last saved will remain in effect.

## 2-10 CPRI Analyzer Menu Map

Figure 2-40 and Figure 2-41 illustrate the CPRI Analyzer main menu map, showing all possible submenu keys, although some keys may be displayed on the instrument only under special circumstances. Additional menus and submenus are shown on the next pages.

Unless noted otherwise, menu maps, soft keys, and associated interface screens illustrated in this document depict an Anritsu test instrument equipped with a touch screen. If your instrument model has no touch screen, refer to the model's User Guide for a description of the user interface.

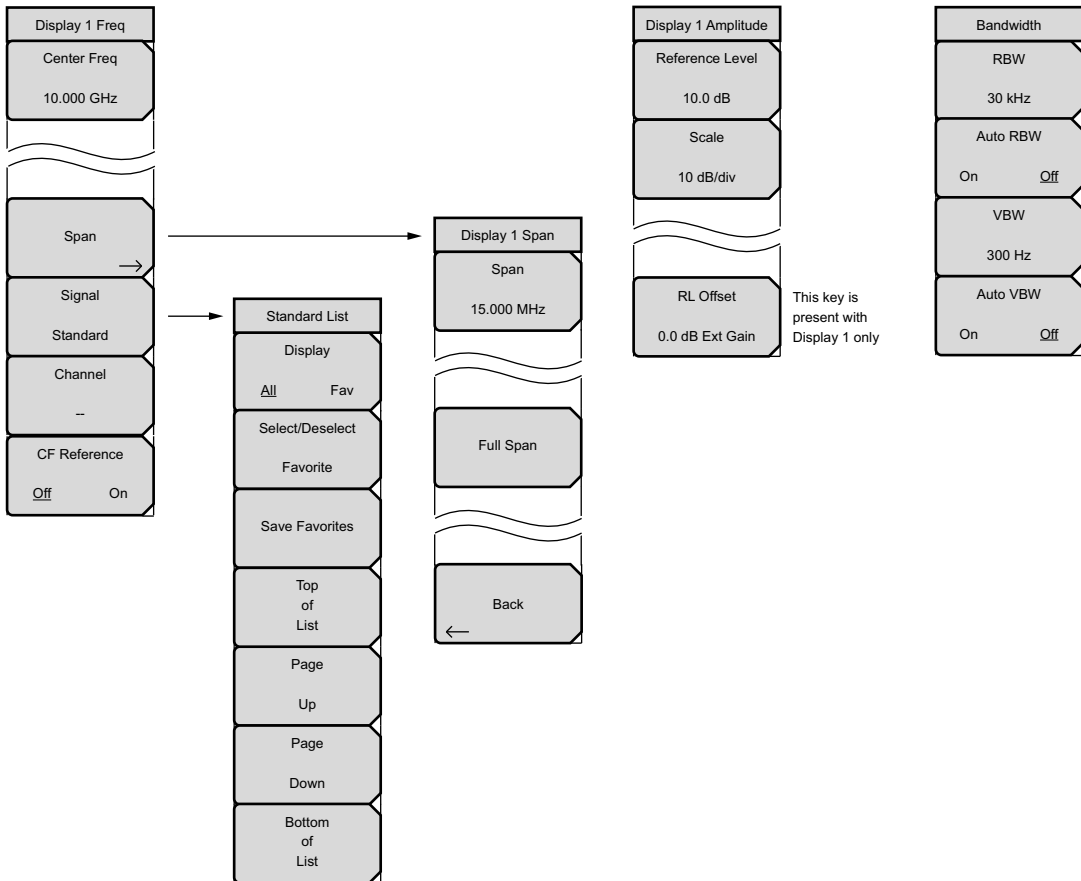


Figure 2-40. Main Menu Map (1 of 2)

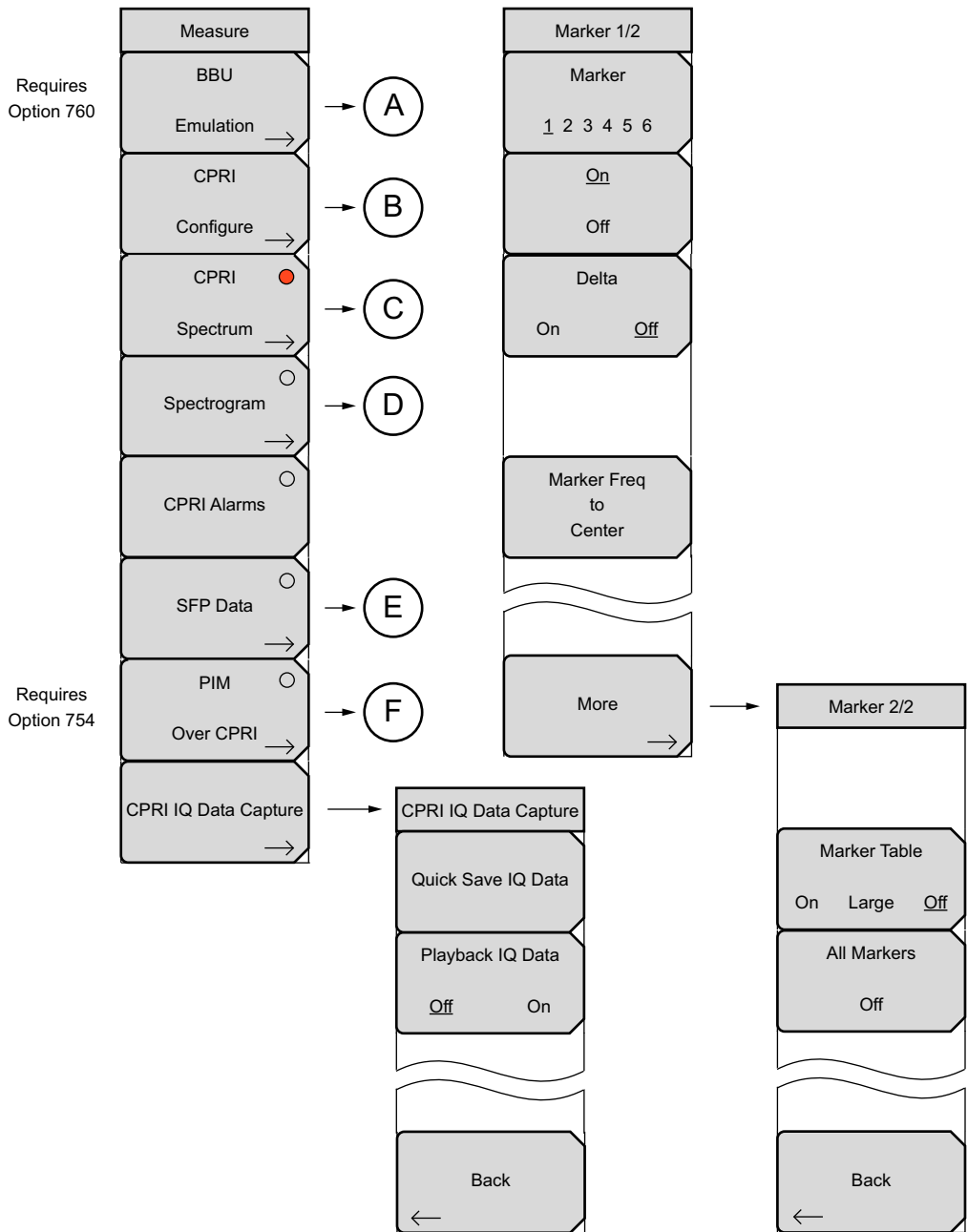


Figure 2-41. Main Menu Map (2 of 2)

### Measurements Menu Map

Figure 2-42 through Figure 2-46 show the CPRI Analyzer Measurements menu and submenus.

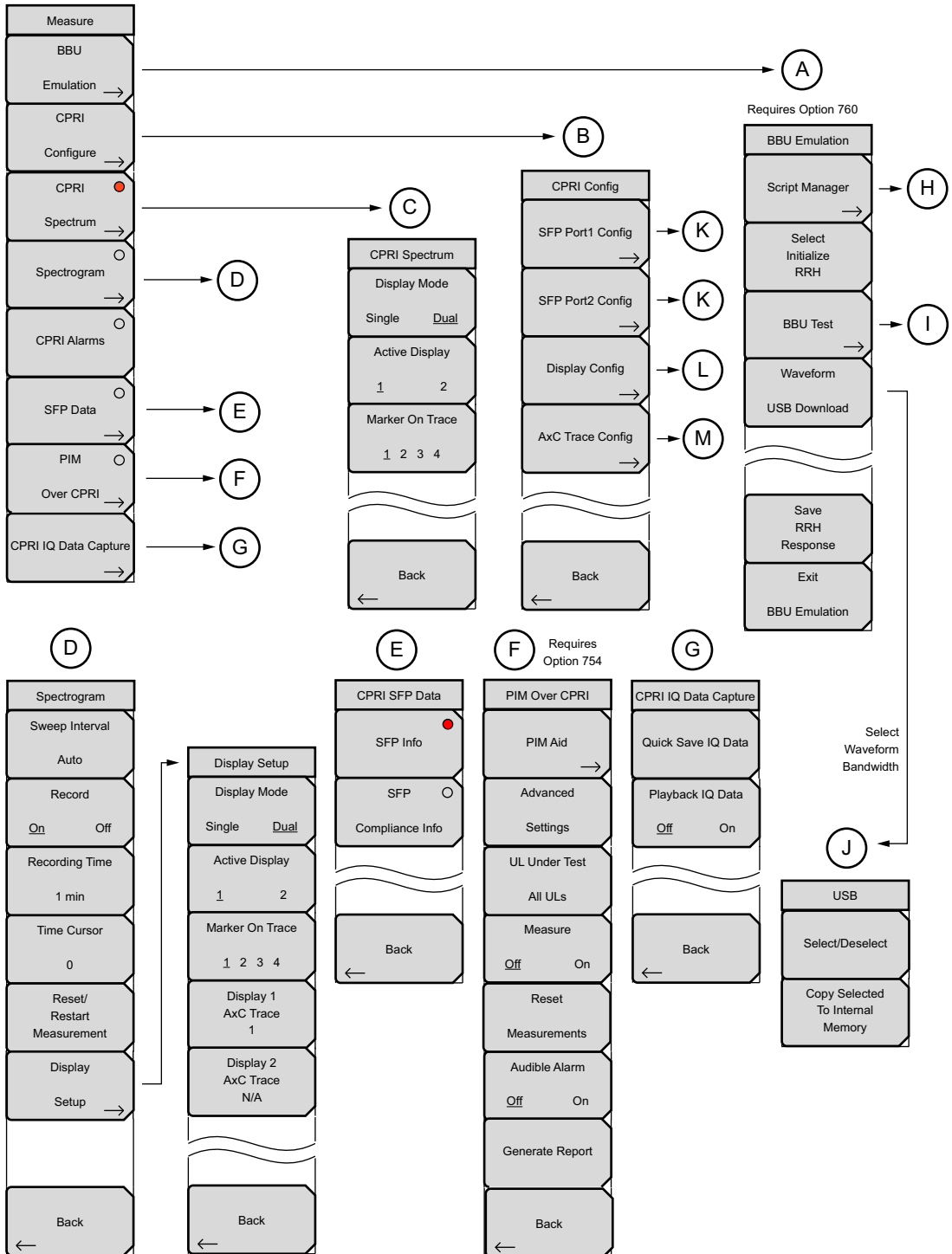


Figure 2-42. Measurements Menu Map (1 of 5)

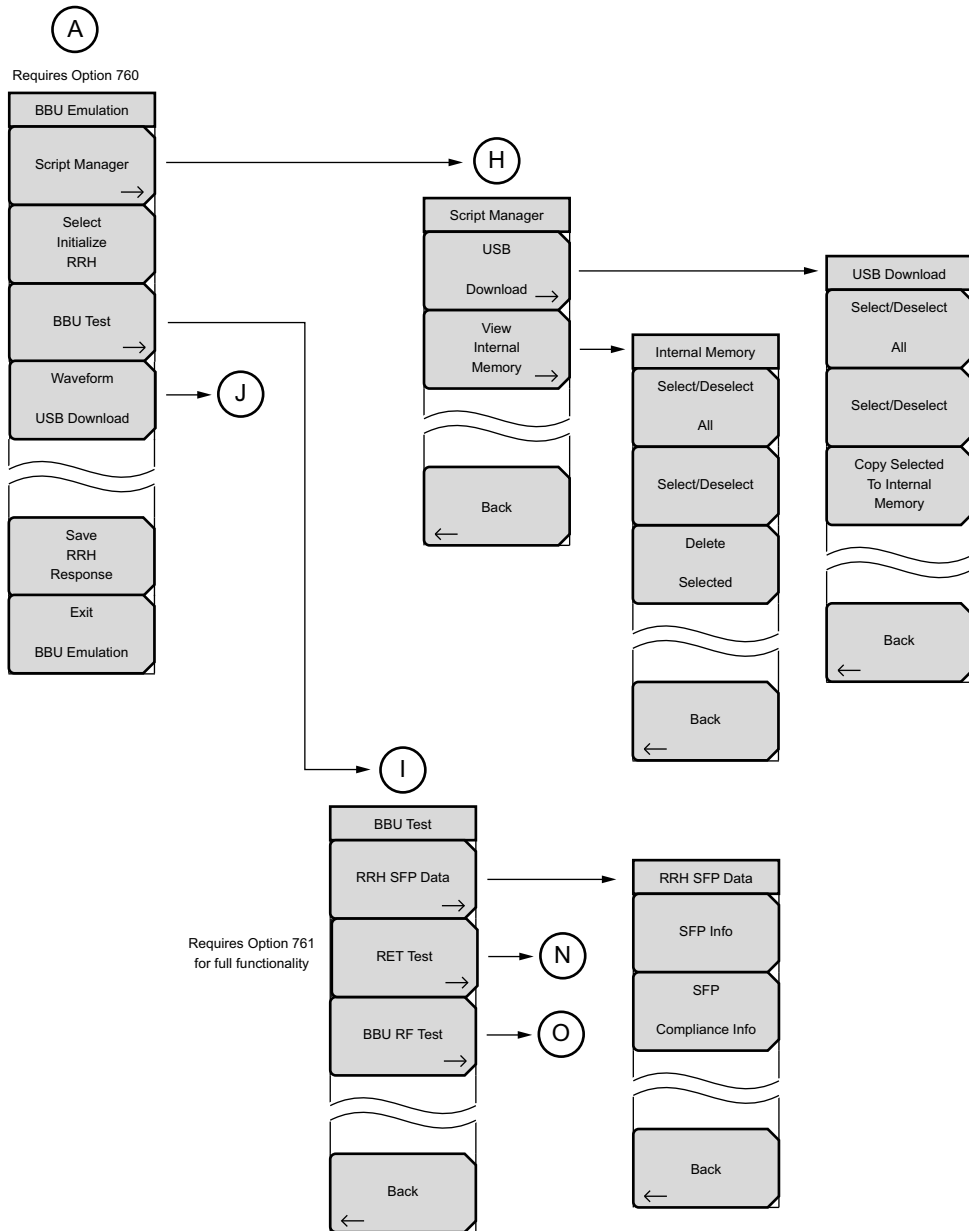


Figure 2-43. Measurements Menu Map (2 of 5)

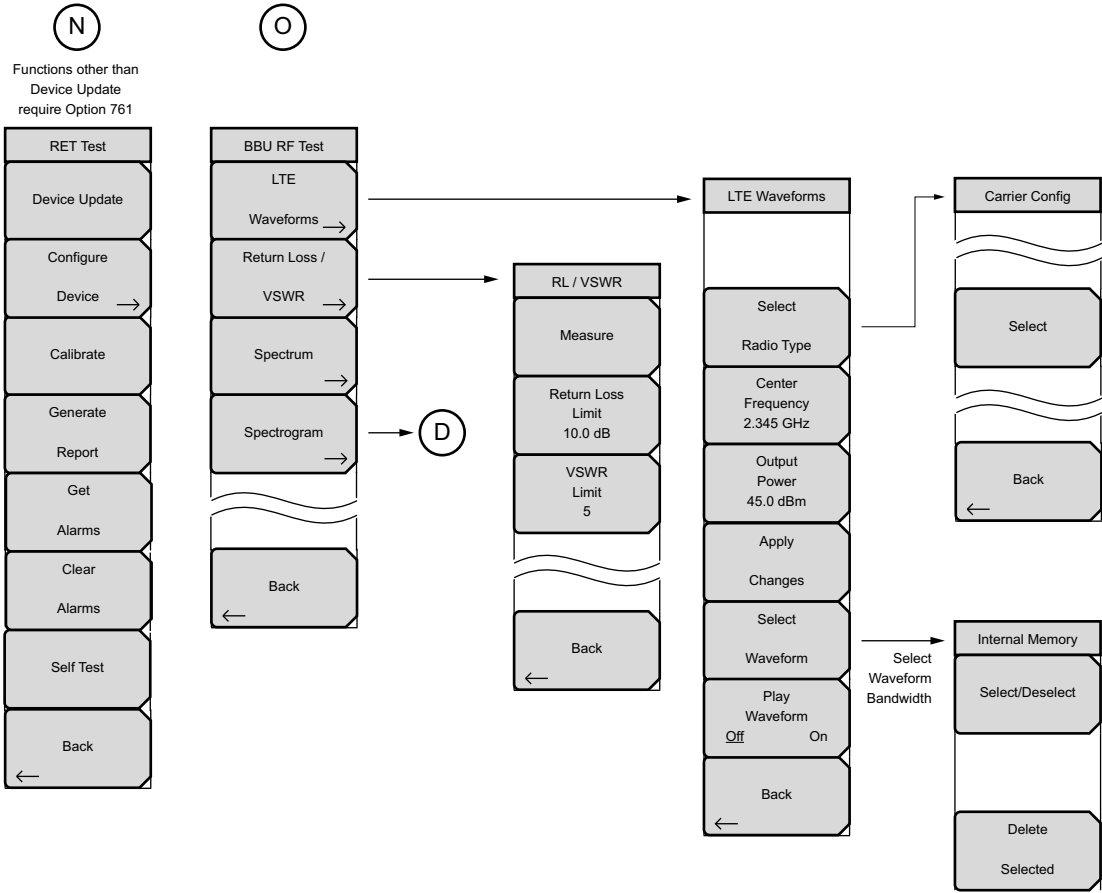


Figure 2-44. Measurements Menu Map (3 of 5)

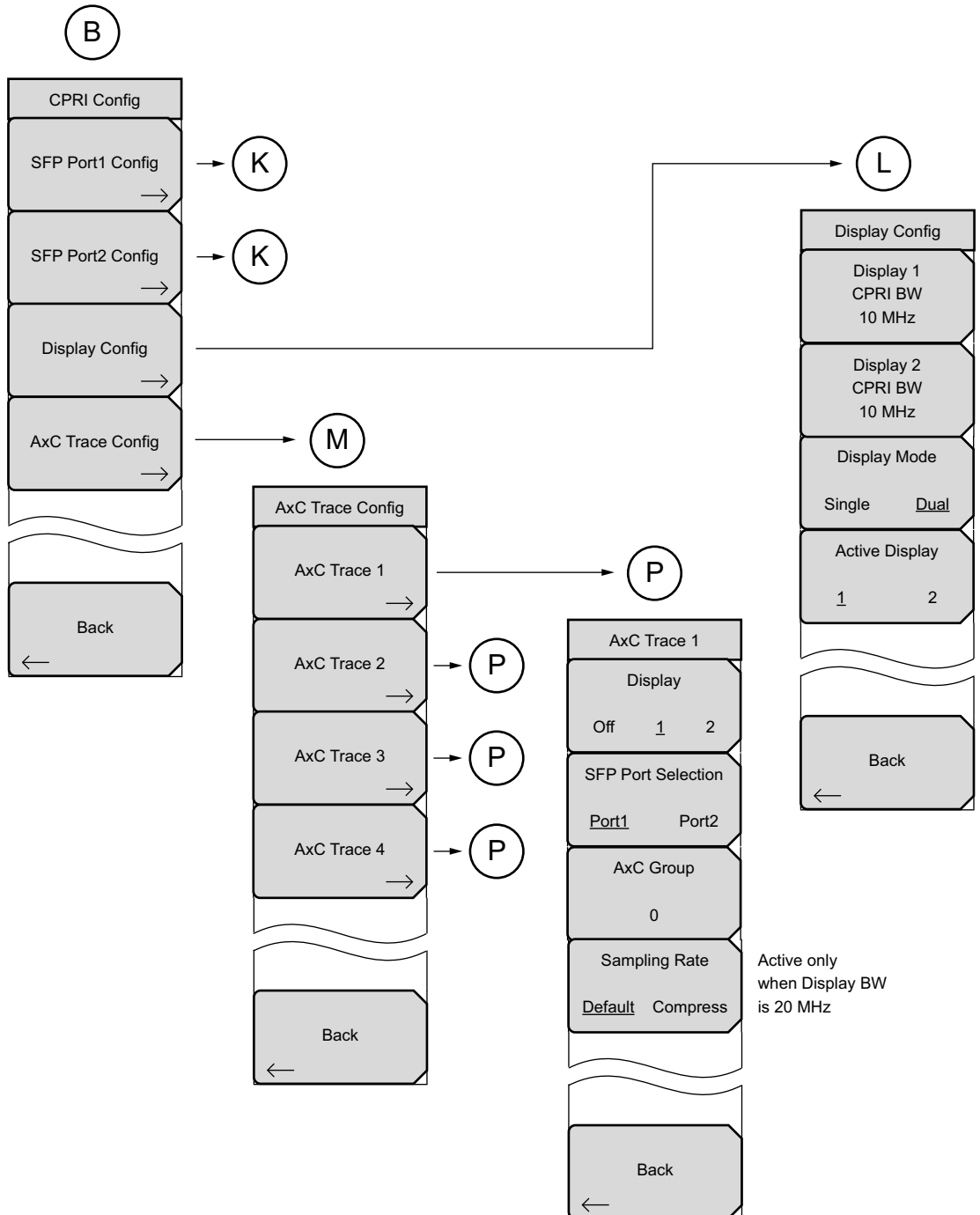
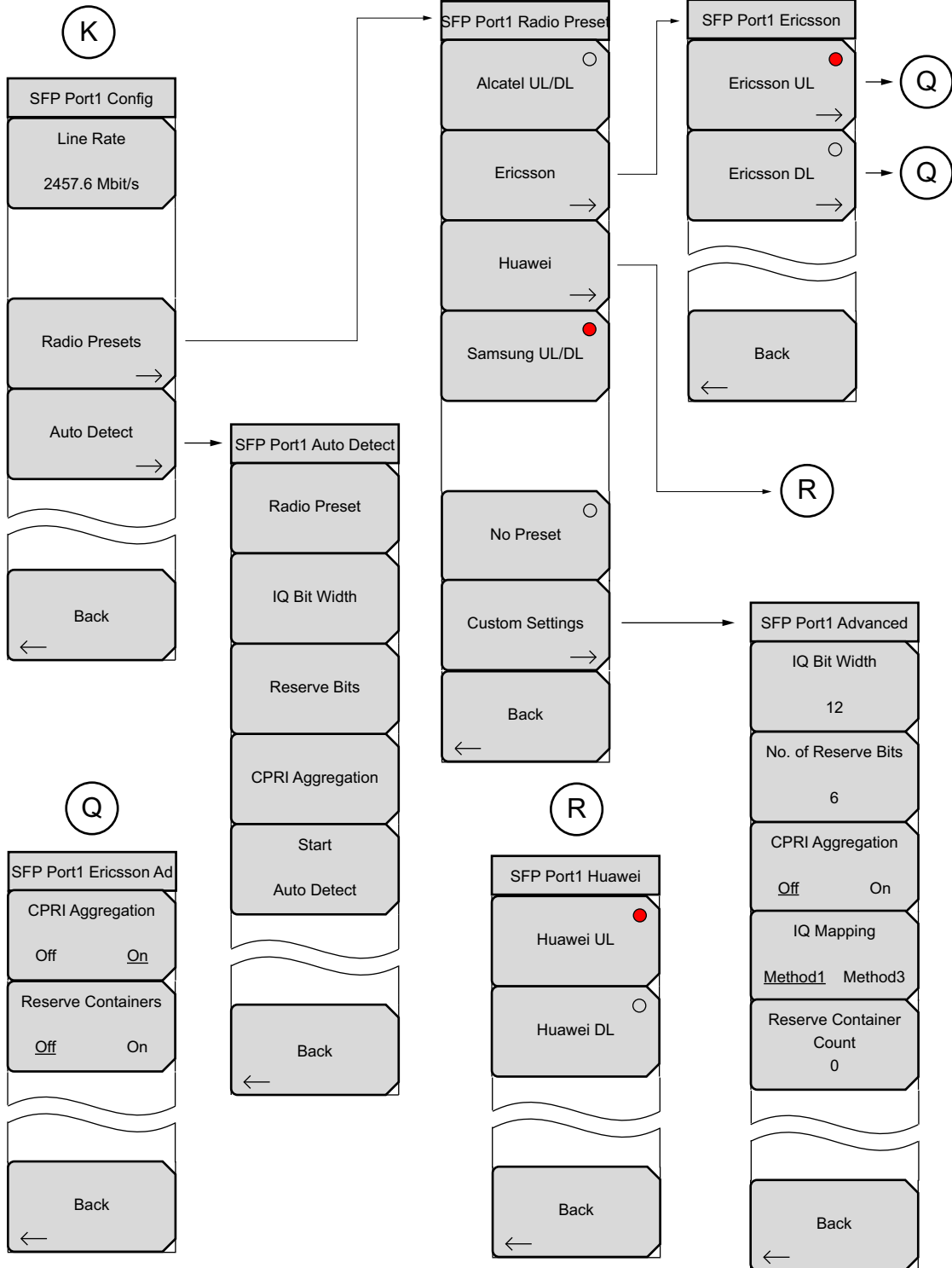


Figure 2-45. Measurements Menu Map (4 of 5)



The same configuration menus are available for SFP Port 1 and Port 2.

Figure 2-46. Measurements Menu Map (5 of 5)

### Sweep Menu

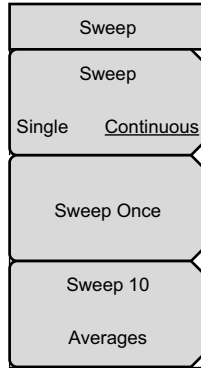


Figure 2-47. Sweep Submenu Keys

### Trace Menus

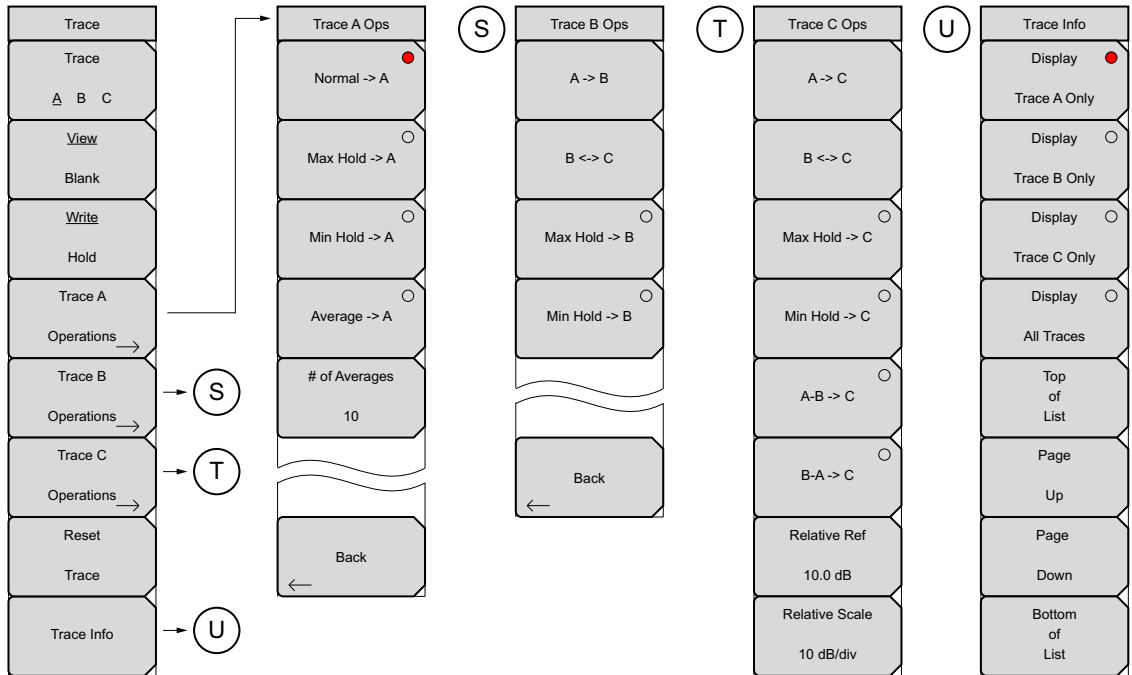


Figure 2-48. Trace Submenu Keys

Limit Menus

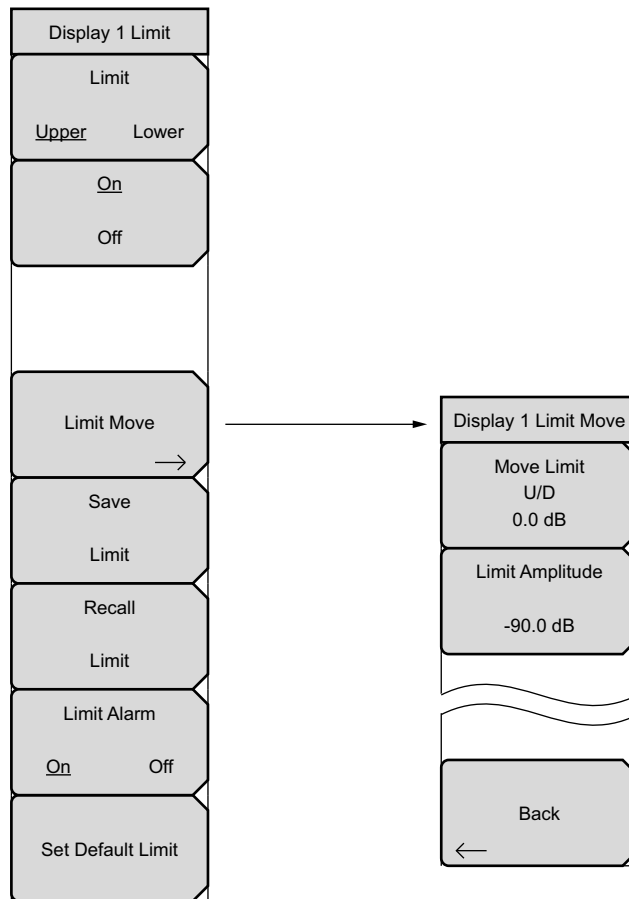


Figure 2-49. Limit Submenu Keys

## 2-11 Freq Menu

Key Sequence: **Freq**

<div style="border: 1px solid black; padding: 5px; margin-bottom: 5px;">                 Display 1 Freq                  Center Freq                  10.000 GHz             </div> <div style="border: 1px solid black; padding: 5px; margin-bottom: 5px;">                 Span                  →             </div> <div style="border: 1px solid black; padding: 5px; margin-bottom: 5px;">                 Signal                  Standard             </div> <div style="border: 1px solid black; padding: 5px; margin-bottom: 5px;">                 Channel                  --             </div> <div style="border: 1px solid black; padding: 5px; margin-bottom: 5px;">                 CF Reference                  Off      On             </div> <div style="border: 1px solid black; padding: 5px; margin-bottom: 5px;">                 Standard List             </div> <div style="border: 1px solid black; padding: 5px; margin-bottom: 5px;">                 Display                  All      Fav             </div> <div style="border: 1px solid black; padding: 5px; margin-bottom: 5px;">                 Select/Deselect                  Favorite             </div> <div style="border: 1px solid black; padding: 5px; margin-bottom: 5px;">                 Save Favorites             </div> <div style="border: 1px solid black; padding: 5px; margin-bottom: 5px;">                 Top                  of                  List             </div> <div style="border: 1px solid black; padding: 5px; margin-bottom: 5px;">                 Page                  Up             </div> <div style="border: 1px solid black; padding: 5px; margin-bottom: 5px;">                 Page                  Down             </div> <div style="border: 1px solid black; padding: 5px;">                 Bottom                  of                  List             </div>	<p>Settings under the Freq menu apply to the currently active display as indicated in the menu title (Display 1 or 2).</p> <p><b>Center Freq:</b> Press this key, then enter the desired frequency using the numeric keypad, the arrow keys, or the rotary knob. If entering a frequency with the keypad, the menu key labels will change to GHz, MHz, kHz, and Hz. Press the appropriate Units key. Pressing the <b>Enter</b> key selects MHz as the default frequency unit.</p> <p>To allow the CPRI signal to move off center (pan), adjust the center frequency to a different value. Depending on the value entered, this may automatically adjust the frequency span, as there cannot be panning without zooming.</p> <p><b>Span:</b> Press this submenu key to display the <a href="#">“Span Menu” on page 2-50</a>.</p> <p><b>Signal Standard:</b> Press this key to open the Standard List menu shown on the left and display the Signal Standards list box illustrated in <a href="#">Figure 2-51</a> and <a href="#">Figure 2-52</a>. You can select a standard from the complete list or from a list of previously saved Favorites. Use the touch screen, arrow keys, or rotary knob to highlight a signal standard, then press <b>Enter</b> to select.</p> <p>To add a standard to a Favorites list, highlight the desired standard in the “Display All” view and press Select/Deselect Favorite. An asterisk (*) appears next to the standard name. Press Save Favorites.</p> <p>To remove a standard from the Favorites list, highlight the item marked with an asterisk in either the All View or the Favorites View and press Select/Deselect Favorite, then press Save Favorites.</p> <p><b>Channel:</b> After selecting a signal standard, press this key to display the Channel Editor dialog. Enter a valid band. See <a href="#">Figure 2-53 on page 2-49</a>.</p> <p><b>CF Reference Off/On:</b> Press this submenu key to toggle the center frequency reference setting On or Off. When set to On, you can pan and zoom by adjusting the center frequency and span. This feature is available only when Display 1 is active.</p> <p><b>Display All/Fav:</b> Press this key to toggle between displaying the complete Standards List or the Favorites List. Items previously saved as favorites are marked with an asterisk (*).</p> <p><b>Select/Deselect Favorite:</b> Press this key to mark or unmark the currently highlighted standard as a favorite. Any changes you make are not saved until you press Save Favorites or <b>Enter</b>.</p> <p><b>Save Favorites:</b> Saves the Favorites list with all standards that are marked with an asterisk.</p> <p>Use the navigation keys to quickly scroll through the Standards List.</p>
--	--

**Figure 2-50.** Frequency Menu

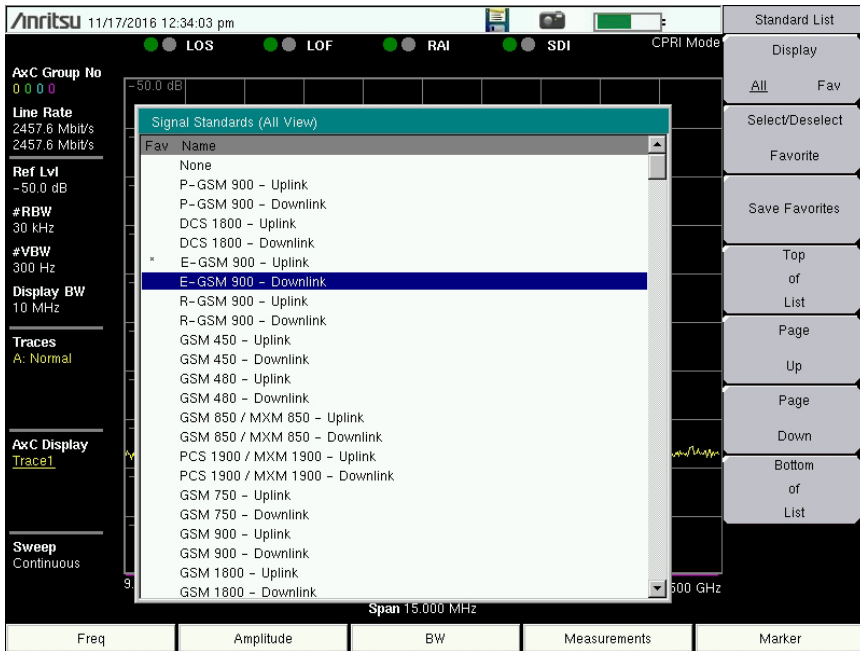


Figure 2-51. Signal Standards List - All View

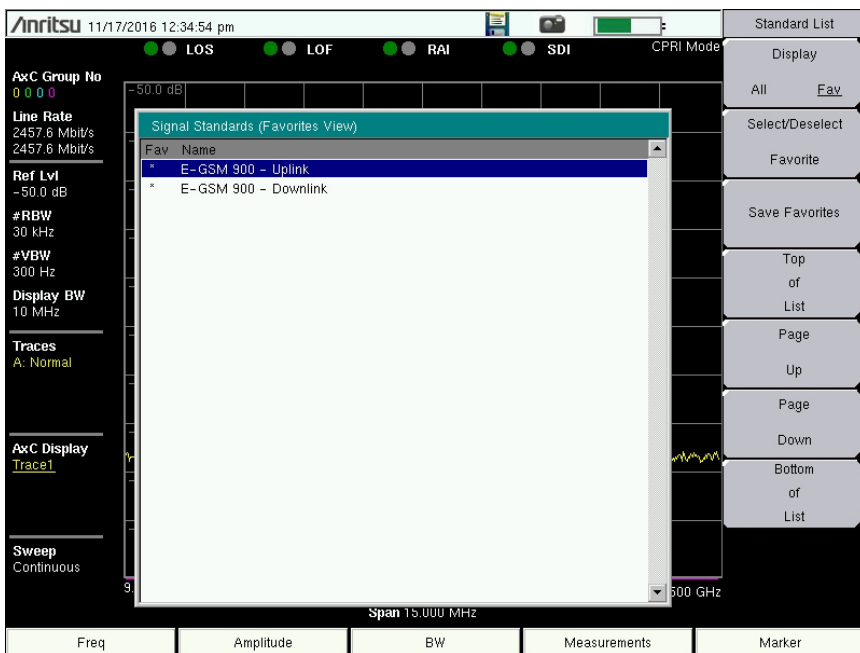


Figure 2-52. Signal Standards List - Favorites View

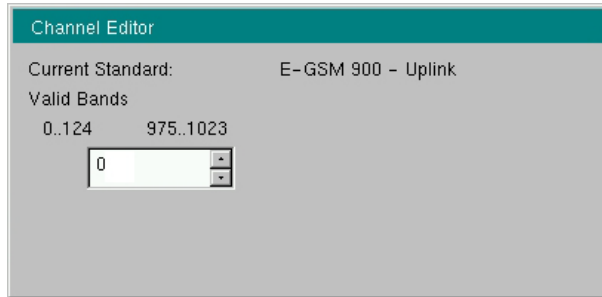
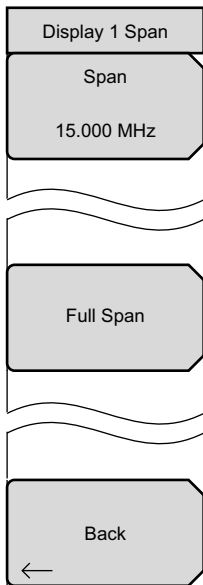


Figure 2-53. Channel Editor Dialog Box

## 2-12 Span Menu

Key Sequence: **Freq** > Span



Settings under the Span menu apply to the currently active display as indicated in the menu title (Display 1 or 2).

**Span:** This submenu key shows the current value for span in units of GHz, MHz, kHz, or Hz. When the Span button is pressed, span becomes the active parameter and may be changed. Use the keypad, the directional arrow keys, or the rotary knob to increase or decrease the frequency span. If the span is changed using the arrow keys or rotary knob, the span changes in steps of 0.5 MHz. If entering a span with the keypad, the submenu key labels will change to GHz, MHz, kHz, and Hz. Press the appropriate Units key. Pressing the **Enter** key selects MHz as the default frequency unit.

Use the frequency span to zoom in to the CPRI signal. A span setting of 0 Hz (or zero span) is not allowed in CPRI mode. The maximum span is the carrier bandwidth + 50%. The minimum span is 10 kHz. If you attempt to set a span of less than 10 kHz, the instrument will apply the default minimum span of 10 kHz.

**Full Span:** Pressing this key sets the span to cover the entire tunable spectrum of the instrument.

**Back:** Returns to the [“Freq Menu” on page 2-47](#).

**Figure 2-54.** Span Menu

## 2-13 Amplitude Menu

Key Sequence: **Amplitude**

<p>Display 1 Amplitude</p>	<p>Settings under the Amplitude menu apply to the currently active display as indicated in the menu title (Display 1 or 2).</p>
<p>Reference Level</p> <p>10.0 dB</p>	<p><b>Reference Level:</b> The reference level is the top grid line of the sweep window and can be set from +30 dB to -150 dB. Press this key, then use the arrow keys or the rotary knob to change the reference level value.</p>
<p>Scale</p> <p>10 dB/div</p>	<p>To enter a negative value with the numeric keypad, press the +/- key for a minus sign. After entering the value, press the dB submenu key or the <b>Enter</b> key to apply.</p>
<p>The reference level value may be modified by the reference level offset value to compensate for an external attenuator or amplifier.</p>	
<p>RL Offset</p> <p>0.0 dB Ext Gain</p>	<p><b>Scale:</b> The scale can be set in 1 dB steps from 1 dB per division to 15 dB per division. The value can be changed using the keypad, the rotary knob, or the arrow keys.</p>
<p><b>RL Offset:</b> RL Offset compensates for the presence of external input attenuation or gain. It applies to Display 1 only, whether the display mode is single or dual. Press this key, then use the arrow keys or the rotary knob to change the offset value. You can also enter a value using the numeric keypad, then select dB External Gain or dB External Loss as appropriate.</p>	

Figure 2-55. Amplitude Menu

## 2-14 Units of External Gain or Loss

Key Sequence: **Amplitude** > RL Offset > **Keypad** Entry

<p>Units</p>	<p><i>These units are for RL Offset Gain or Loss.</i></p>
<p>dB</p> <p>External Gain</p>	<p><b>dB External Gain:</b> Enter a value with the numeric keypad, then press this submenu key for external gain. Use the +/- key for a negative value. Note that a negative external gain equates to an external loss.</p>
<p>dB</p> <p>External Loss</p>	<p><b>dB External Loss:</b> Enter a value with the numeric keypad, then press this submenu key for external loss. Use the +/- key for a negative value. A negative external loss equates to an external gain.</p>
<p>The Backspace key is used to delete the last digit entered.</p>	
<p>Backspace</p> <p>←</p>	<p><b>Backspace:</b> Press this submenu key to delete the last digit entered.</p>

Figure 2-56. Units Menu for External Gain or Loss

## 2-15 Bandwidth Menu

Key Sequence: **BW**

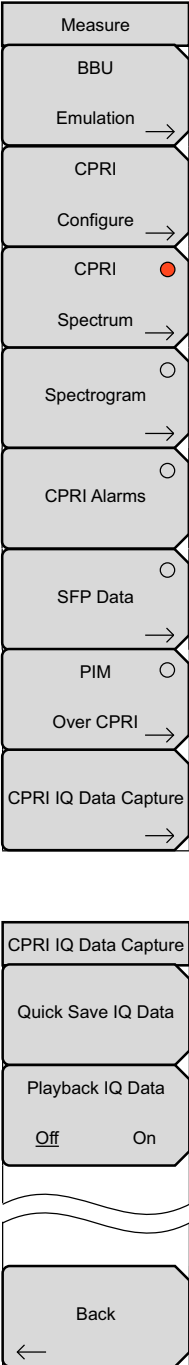
<div style="border: 1px solid black; padding: 2px; margin-bottom: 2px;">Bandwidth</div> <div style="border: 1px solid black; padding: 2px; margin-bottom: 2px;">RBW 30 kHz</div> <div style="border: 1px solid black; padding: 2px; margin-bottom: 2px;">Auto RBW On      <u>Off</u></div> <div style="border: 1px solid black; padding: 2px; margin-bottom: 2px;">VBW 300 Hz</div> <div style="border: 1px solid black; padding: 2px;">Auto VBW On      <u>Off</u></div>	<p><b>RBW:</b> The current resolution bandwidth value is displayed in this submenu key. The RBW can be changed using the keypad, the arrow keys, or the rotary knob. The value range is 300 Hz to 1 MHz. Available settings are: 300 Hz, 1 kHz, 3 kHz, 10 kHz, 30 kHz, 100 kHz, 300 kHz, and 1 MHz.</p> <p>The RBW value changes automatically when the frequency span is changed and Auto RBW is on. In this case, the new RBW value is an approximation selected out of the valid settings listed above, based on a span to resolution bandwidth ratio of 100. Manually changing the resolution bandwidth turns off the Auto RBW setting.</p> <p><b>Auto RBW On/Off:</b> This parameter controls the coupling state of RBW to the frequency span. When Auto RBW is set to on, the instrument adjusts the RBW value automatically based on the current frequency span. The ratio of span to RBW is 100, meaning that the span width is approximately 100 times the resolution bandwidth. The value is approximate because resolution bandwidth filters come in discrete steps while span width can be set to any value up to the maximum span of the instrument. To disassociate RBW from the span, turn off Auto RBW.</p> <p><b>VBW:</b> The current video bandwidth value is displayed in this submenu key. The VBW can be changed using the keypad, arrow keys, or the rotary knob. The value range is 30 Hz to 1 MHz. Available settings are: 30 Hz, 100 Hz, 300 Hz, 1 kHz, 3 kHz, 10 kHz, 30 kHz, 100 kHz, 300 kHz, and 1 MHz.</p> <p>The VBW value changes automatically when RBW is changed and Auto VBW is on, in which case VBW is an approximation selected out of the valid frequencies listed above, based on an RBW/VBW ratio of 3. For example, if RBW is 1 MHz, VBW will be 300 kHz. Manually changing the video bandwidth turns off Auto VBW.</p> <p><b>Auto VBW On/Off:</b> This parameter sets the coupling state of the video bandwidth to the resolution bandwidth. When Auto VBW is on, the instrument automatically adjusts the VBW value to one third (1/3) the current RBW setting. To disassociate VBW from RBW, turn off Auto VBW.</p>
---	---

**Figure 2-57.** Bandwidth Menu

## 2-16 Measure Menu

Key Sequence: **Measurements**

or: **Shift > Meas (4)**



The screenshot shows a vertical list of menu items. The 'Measure' menu is expanded to show submenus: BBU Emulation, CPRI Configure, CPRI Spectrum, CPRI Spectrogram, CPRI Alarms, SFP Data, PIM Over CPRI, and CPRI IQ Data Capture. The 'CPRI IQ Data Capture' submenu is further expanded to show 'Quick Save IQ Data', 'Playback IQ Data' (with 'Off' selected), and a 'Back' button.

**BBU Emulation:** This submenu key opens the “[BBU Emulation Menu \(Option 760 Only\)](#)” on page 2-55.

**CPRI Configure:** This submenu key opens the “[CPRI Config Menu](#)” on page 2-66.

**CPRI Spectrum:** Press this key to select the CPRI spectrum view. Depending on the current display mode, you may have to press the key a second time to open the “[CPRI Spectrum Menu](#)” on page 2-74.

**Spectrogram:** Press this key to select the spectrogram view and open the “[Spectrogram Menu](#)” on page 2-75.

**CPRI Alarms:** Press this key to display the SFP port alarm status and the Tx and Rx optical power levels. See [Figure 2-59 on page 2-54](#) for an example of a dual-port display. “Pass” status is shown as green; “Fail” is red. Colors may appear differently depending on the display settings. No color, or grey, means there is no connection at the SFP port.

**SFP Data:** This key opens the “[CPRI SFP Data Menu](#)” on page 2-78.

**CPRI IQ Data Capture:** Press this key to access the IQ Data Capture function described below.

**PIM Over CPRI:** This key opens the “[PIM Over CPRI Menu \(Option 754 Only\)](#)” on page 2-80.

**Quick Save IQ Data:** Insert a USB storage device into the Anritsu test instrument before pressing this key to initiate a waveform data capture. The IQ data is saved in a date and time labeled text file at the root level of the USB device. The file name is of the form `CpriIQStreamDataYYYYMMDDHHMMSS.txt`.

The instrument will display a message if there is no USB device connected or not enough space is available.

**Playback IQ Data:** Displays previously saved IQ data. Measurement and display settings are unchanged.

**Back:** Returns to the “[Measure Menu](#)”.

**Figure 2-58.** Measure Menu

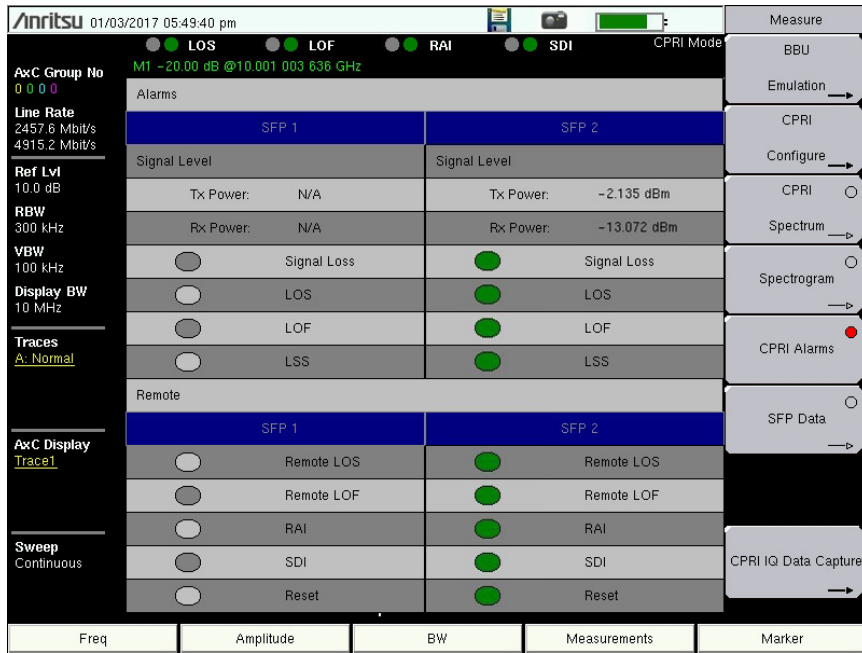
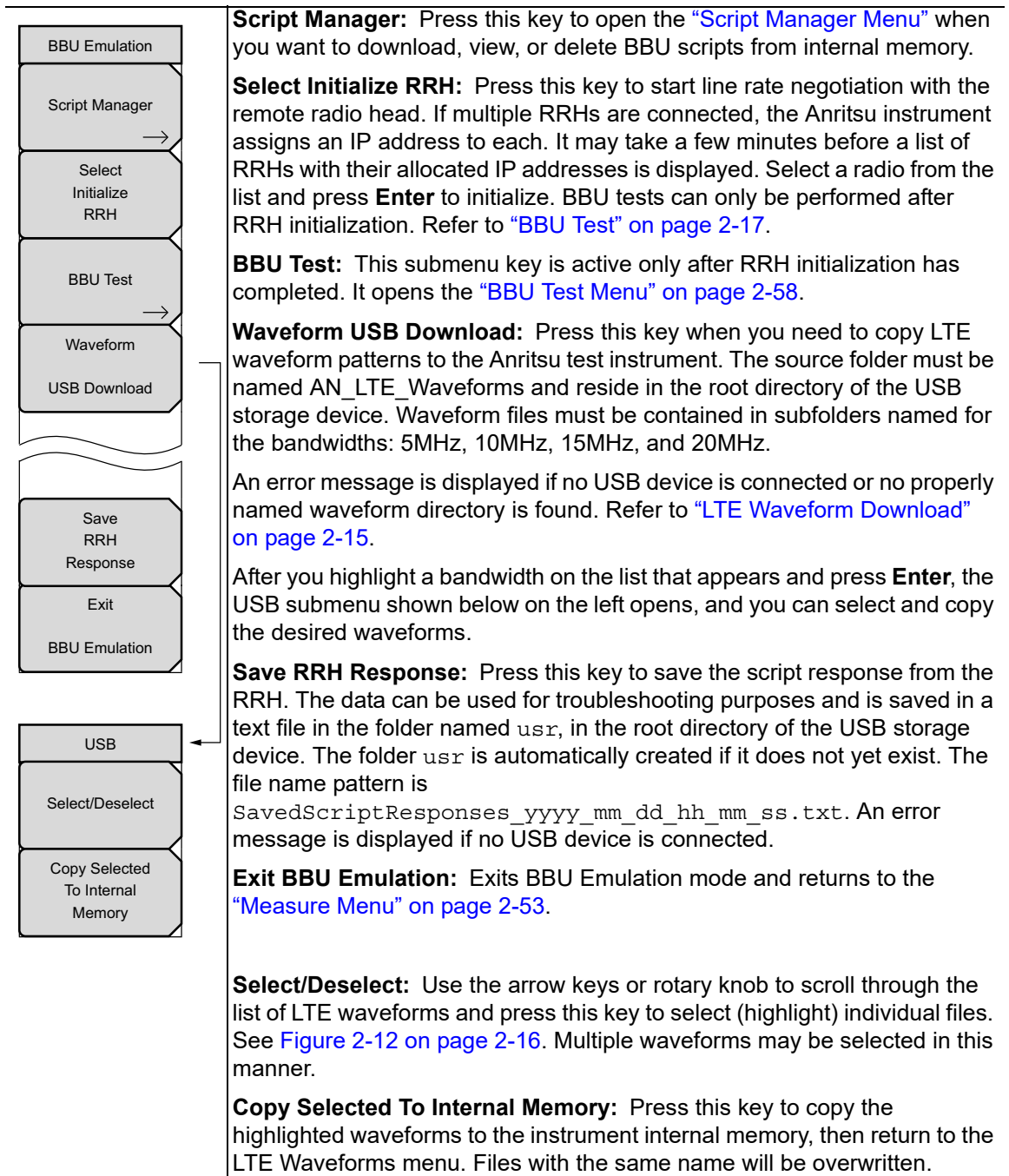


Figure 2-59. CPRI Alarms Screen (Dual-Port Model Is Shown)

## 2-17 BBU Emulation Menu (Option 760 Only)

Key Sequence: **Measurements** > BBU Emulation



**Figure 2-60.** BBU Emulation Menu (Option 760 Only)

## 2-18 Script Manager Menu

Key Sequence: **Measurements** > BBU Emulation > Script Manager

	<p><b>USB Download:</b> Press this key to open the USB Download menu shown below on the left and display the list of script files found on the connected USB device (see <a href="#">Figure 2-62</a>). This key only works when a USB device containing a valid BBU script directory (BBUEmulationScripts/aluscripts) is inserted in the instrument USB port.</p>
<p>Back</p>	<p>Note that BBU scripts are included with Option 760. Only use this key if you need to reload the scripts or download other scripts.</p>
	<p><b>View Internal Memory:</b> This submenu key opens the Internal Memory menu and displays the list of BBU scripts loaded in internal memory. From the menu, you can select and delete script files. See <a href="#">Figure 2-63</a>.</p>
<p>USB Download</p>	<p><b>Back:</b> Returns to the “<a href="#">BBU Emulation Menu (Option 760 Only)</a>”.</p>
<p>Select/Deselect All</p>	<p><b>Select/Deselect All:</b> Press this key to select or deselect all script files contained in the BBU script directory on the USB device. See <a href="#">Figure 2-62</a>.</p>
<p>Select/Deselect</p>	<p><b>Select/Deselect:</b> Use the arrow keys or rotary knob to scroll through the list of BBU scripts and press this key to select (highlight) individual files. Multiple scripts may be selected in this manner.</p>
<p>Copy Selected To Internal Memory</p>	<p><b>Copy Selected To Internal Memory:</b> Press this key to copy the highlighted script or scripts to the instrument internal memory, then return to the Script Manager menu. Files with the same name will be overwritten.</p>
<p>Back</p>	<p><b>Back:</b> Returns to the “<a href="#">Script Manager Menu</a>”.</p>

Figure 2-61. Script Manager Menu

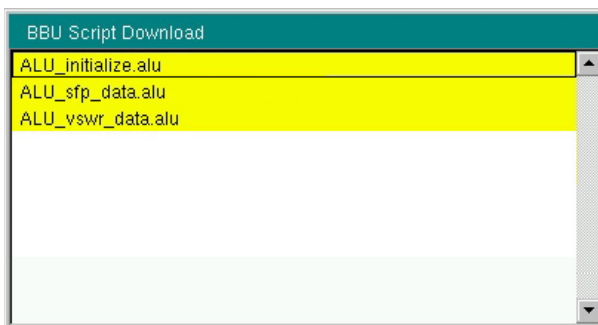
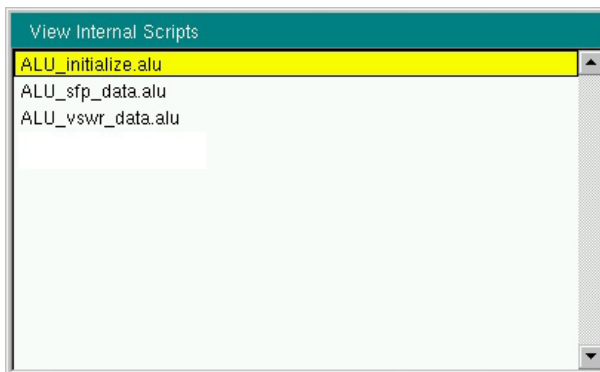


Figure 2-62. BBU Script Download List

Internal Memory	
Select/Deselect All	<b>Select/Deselect All:</b> Press this key to select or deselect all script files currently loaded in the instrument internal memory.
Select/Deselect	<b>Select/Deselect:</b> Use the arrow keys or rotary knob to scroll through the list of internal scripts and press this key to select (highlight) individual files. See <a href="#">Figure 2-64</a> . Multiple scripts may be selected in this manner.
Delete Selected	<b>Delete Selected:</b> Press this key to delete the highlighted script or scripts from internal memory, then return to the Script Manager menu.
~ ~ ~	
Back ←	<b>Back:</b> Returns to the <a href="#">“Script Manager Menu” on page 2-56</a> .

**Figure 2-63.** Internal Memory Menu

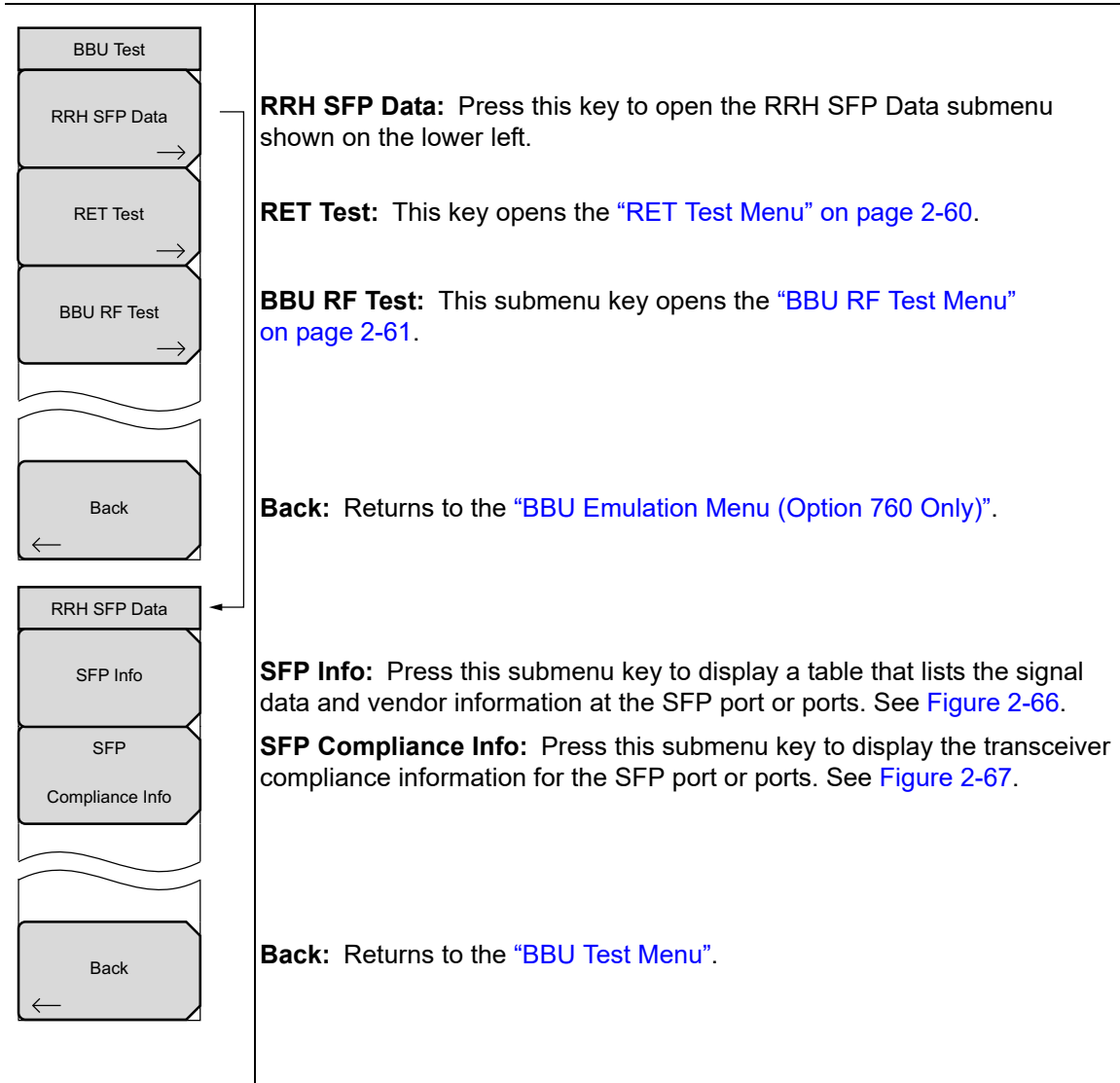


**Figure 2-64.** View Internal Scripts

## 2-19 BBU Test Menu

This function is available only after you have initialized the RRH as described in “[BBU Test](#)” on page 2-17.

Key Sequence: **Measurements** > BBU Emulation > BBU Test



**Figure 2-65.** BBU Test Menu



Figure 2-66. RRH SFP Info Screen

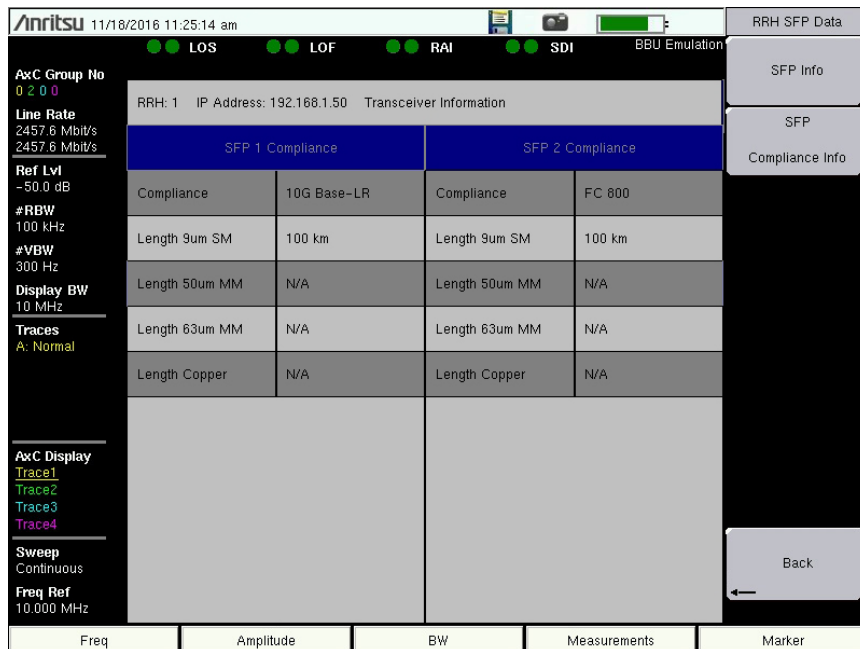


Figure 2-67. RRH SFP Compliance Info Screen

## 2-20 RET Test Menu

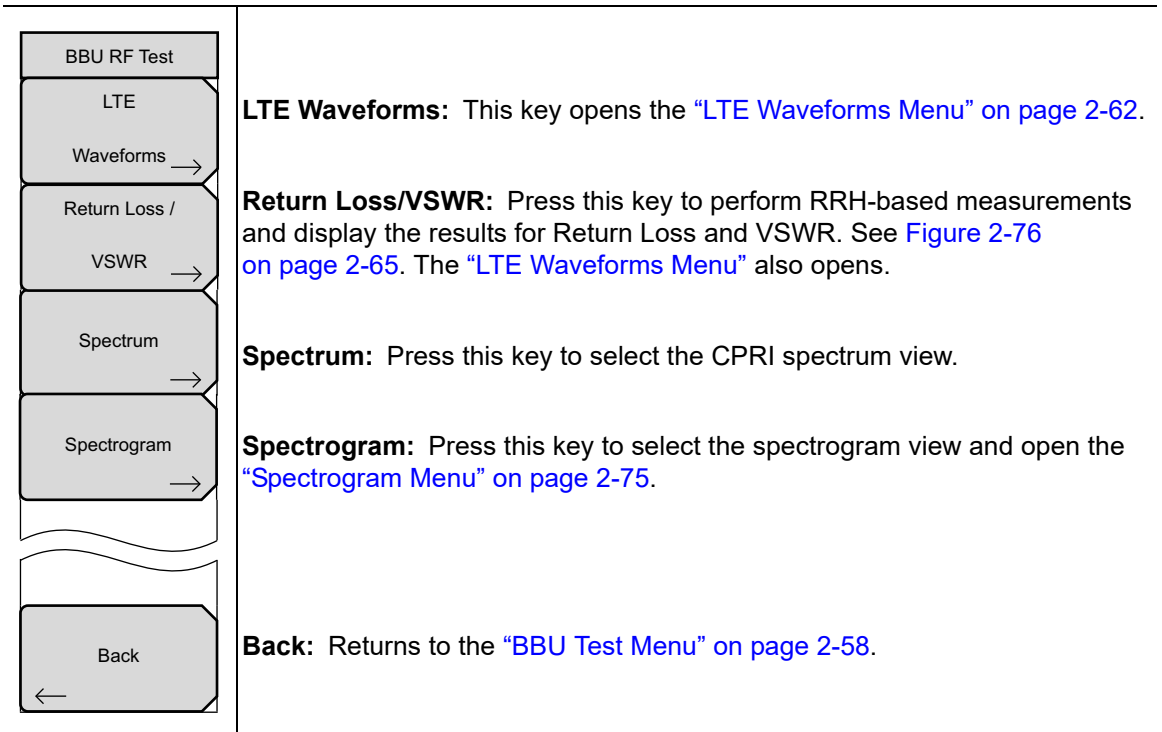
Key Sequence: **Measurements** > BBU Emulation > BBU Test > RET Test

RET Test	<p><b>Device Update:</b> This key initiates a search for RET devices on all CPRI ports. Any new devices found will be added to the current list, sorted by device address. See <a href="#">Figure 2-16 on page 2-19</a>. User-selected configuration settings associated with existing devices are not affected.</p> <p>All RET Test functions other than Device Update require Option 761.</p> <p><b>Configure Device:</b> Press this key to view or change configuration settings of the selected RET device. Only one device can be selected at a time. Use the touch screen or the rotary knob to highlight the field to edit, then press the appropriate keys to change the value. Note that some fields are read-only.</p> <p>The menu keys change depending on the data type of the current configuration field. Some text fields give you the choice of entering the value manually (Edit key) or selecting from a menu (Quick Entry). Refer to <a href="#">“RET Test” on page 2-19</a> for illustrations of the different data entry methods.</p> <p>Newly entered values are lost if you exit the Device Configuration dialog without first pressing Save Configuration. Fields marked with an asterisk (*) cannot be permanently saved to the RET device.</p> <p><b>Calibrate:</b> Press this key to make the actuator on the currently selected RET device move through its entire tilt range. The associated minimum and maximum electrical tilts will display on the device configuration screen. See <a href="#">Figure 2-20 on page 2-21</a> for an example.</p> <p><b>Generate Report:</b> Press this key to create a text file containing the current configuration settings of all RET devices. The file is output to the root directory of the instrument’s internal memory. The file name includes the current date and time, and the file extension is .txtrpt.</p> <p><b>Get Alarms:</b> This key queries the status of the currently selected RET device and displays the results. See <a href="#">Figure 2-17 on page 2-19</a>. Possible alarms include:</p> <ul style="list-style-type: none"> <li>Motor jam</li> <li>Actuator jam</li> <li>NotCalibrated</li> <li>NotConfigured</li> <li>HardwareError</li> <li>ActuatorInterference</li> </ul> <p><b>Clear Alarms:</b> Press this key to attempt to clear alarms on the selected device. Results of the clearing attempt will display. See <a href="#">Figure 2-18 on page 2-20</a>. If the attempt does not clear all of the errors, you will need to take corrective actions to fix them.</p> <p><b>Self Test:</b> Press this key to start a self test on the current device. The test checks for errors as listed for Get Alarms above, and displays the results.</p> <p><b>Back:</b> Returns to the <a href="#">“BBU Test Menu” on page 2-58</a>.</p>
Device Update	
Configure Device →	
Calibrate	
Generate Report	
Get Alarms	
Clear Alarms	
Self Test	
Back ←	

**Figure 2-68.** RET Test Menu

## 2-21 BBU RF Test Menu

Key Sequence: **Measurements** > BBU Emulation > BBU Test > BBU RF Test



**Figure 2-69.** BBU RF Test Menu

## 2-22 LTE Waveforms Menu

Key Sequence: **Measurements** > BBU Emulation > BBU Test > BBU RF Test > LTE Waveforms

LTE Waveforms	
Select Radio Type	<b>Select Radio Type:</b> Press this key to open the Carrier Config submenu shown in <a href="#">Figure 2-71</a> and display the list of radio types.
Center Frequency 2.345 GHz	<b>Center Frequency:</b> Press this key and use the rotary knob or numeric keypad to adjust the carrier frequency of the radio. When using the keypad, press one of the Units keys (GHz, MHz, kHz, or Hz) to enter the value. The default is the center frequency of the RRH.
Output Power 45.0 dBm	<b>Output Power:</b> Press this key and use the rotary knob or numeric keypad to change the transmit power from the RRH. When using the keypad, press the dBm Units key to enter the value. An entered value that is out of range is ignored. The default is 3 dBm below the RRH maximum output power.
Apply Changes	<b>Apply Changes:</b> Press this key to update the RRH configuration with the new center frequency and power settings.  The Apply Changes key must be pressed every time frequency or output power is changed. Play Waveform is disabled until Apply Changes has occurred.
Select Waveform	<b>Select Waveform:</b> Press this key to display a list of bandwidths for the waveforms loaded in the instrument internal memory (see <a href="#">Figure 2-11 on page 2-16</a> ). Select a bandwidth, then press <b>Enter</b> to display the Internal Memory submenu shown in <a href="#">Figure 2-73</a> and a list of LTE waveforms of the selected bandwidth. From the menu, you can select and delete waveform files. See <a href="#">Figure 2-74 on page 2-64</a> .
Play Waveform Off On	<b>Play Waveform</b> <b>Off On:</b> This key is active only after an LTE waveform has been selected and loaded. Press the key (On) to transmit the waveform to the RRH.
Back ←	<b>Back:</b> Returns to the “ <a href="#">BBU RF Test Menu</a> ” on page 2-61.

**Figure 2-70.** LTE Waveforms Menu

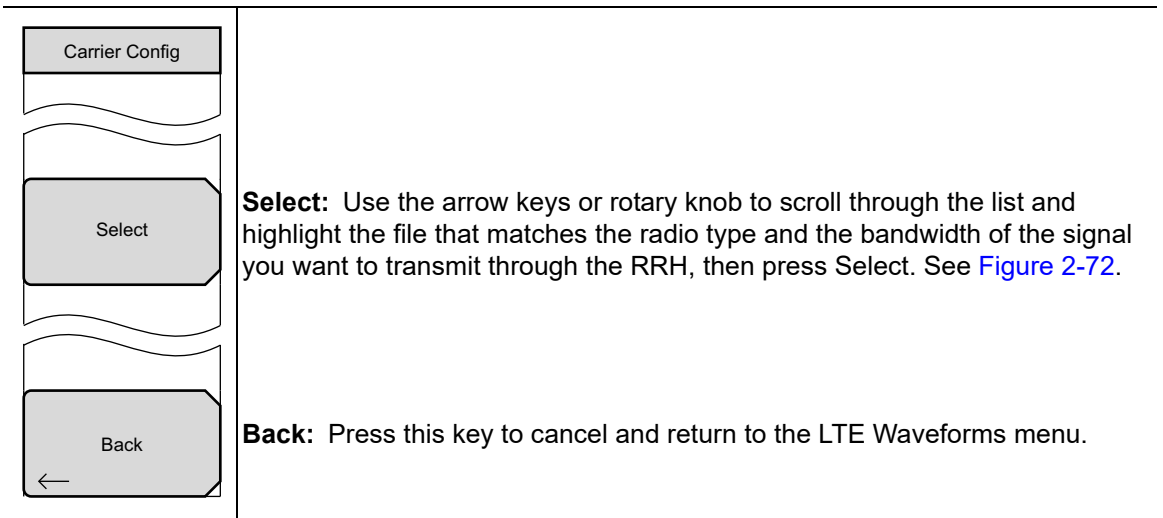


Figure 2-71. Carrier Config Menu

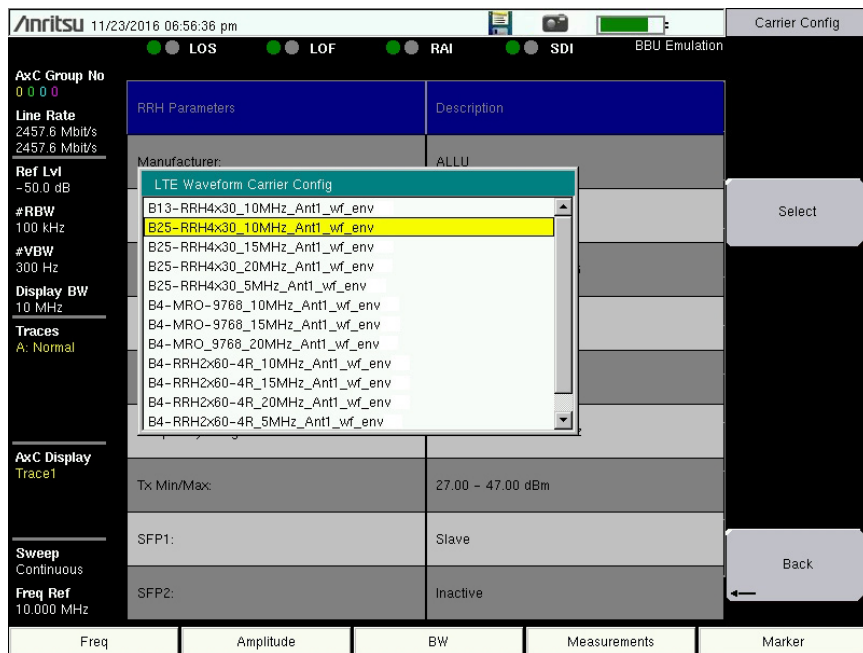


Figure 2-72. LTE Waveform Carrier Configuration



**Select/Deselect:** Use the arrow keys or rotary knob to scroll through the list of LTE waveforms and press this key to select (highlight) the desired file. See [Figure 2-74](#). Multiple waveforms may be selected for deletion in this manner. However, only one waveform can be transmitted to the RRH at a time by pressing Select/Deselect, then **Enter**.

**Delete Selected:** Press this key to delete the highlighted waveforms from the instrument internal memory, then return to the LTE Waveforms menu.

Figure 2-73. Internal Memory Menu

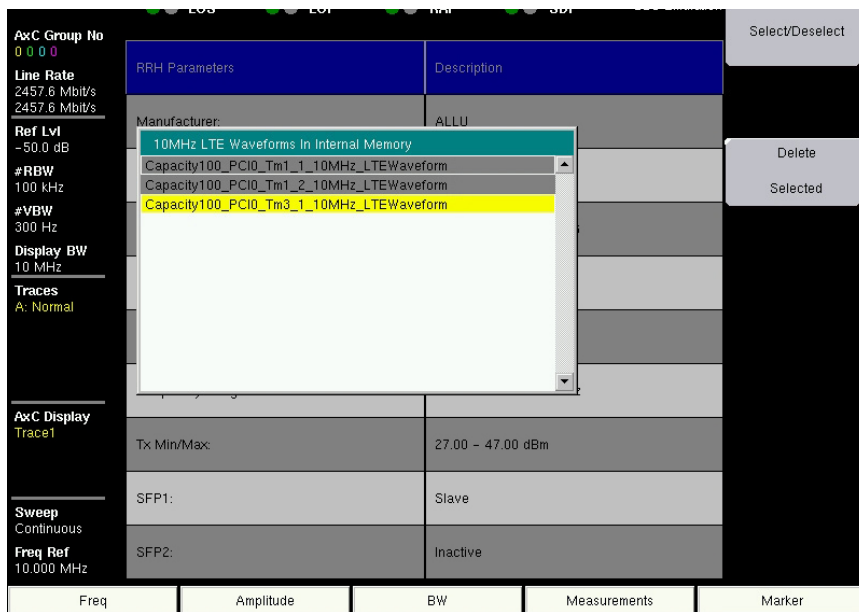


Figure 2-74. LTE Waveforms in Internal Memory

## 2-23 RL/VSWR Menu

Key Sequence: **Measurements** > BBU Emulation > BBU Test > BBU RF Test > Return Loss/VSWR

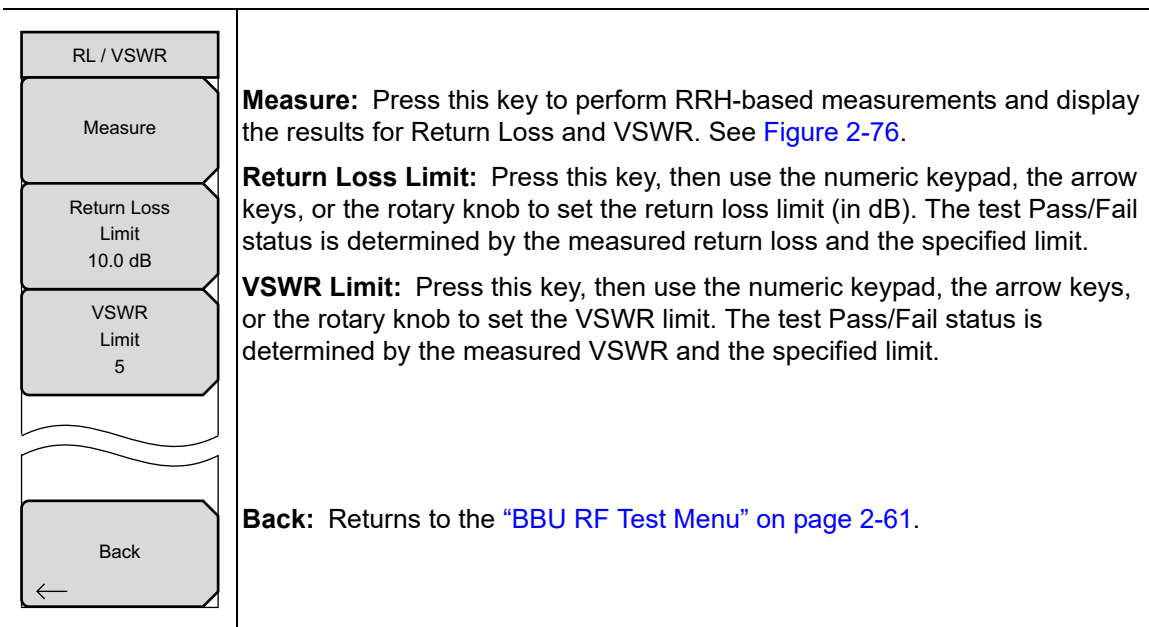


Figure 2-75. RL/VSWR Menu

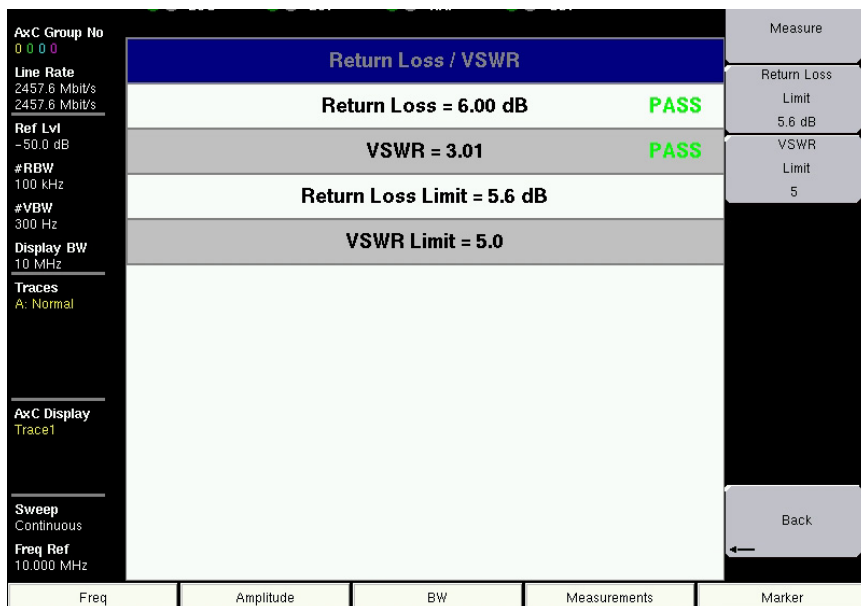
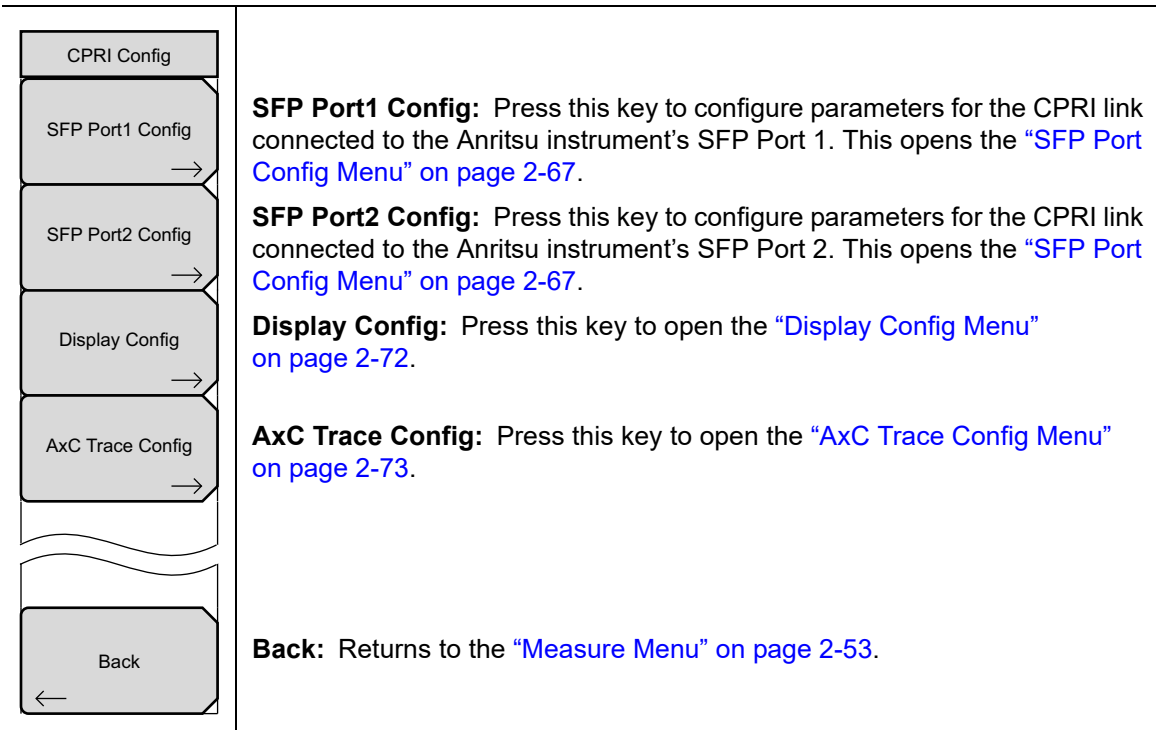


Figure 2-76. Return Loss/VSWR Measurement Results

## 2-24 CPRI Config Menu

Key Sequence: **Measurements** > CPRI Configure



**Figure 2-77.** CPRI Configure Menu

## 2-25 SFP Port Config Menu

Key Sequence: **Measurements** > CPRI Configure > SFP Port1 Config

The same configuration menus are available for SFP Port 1 and Port 2.

SFP Port1 Config	<p><b>Line Rate:</b> Press this submenu key to display the Select Line Rate list box. Use the touch screen, arrow keys, or rotary knob to highlight the CPRI link line rate, then press <b>Enter</b>. Selectable line rates are:</p>
<p>Line Rate 2457.6 Mbit/s</p>	<p>Line Rate 1 = 614.4 Mbit/s Line Rate 2 = 1228.8 Mbit/s Line Rate 3 = 2457.6 Mbit/s Line Rate 4 = 3072.0 Mbit/s Line Rate 5 = 4915.2 Mbit/s Line Rate 6 = 6144.0 Mbit/s Line Rate 7 = 9830.4 Mbit/s Line Rate 8 = 10137.6 Mbit/s</p>
<p>Radio Presets →</p>	<p>There is no need to manually select the CPRI line rate when using the Auto Detect function.</p>
<p>Auto Detect →</p>	<p><b>Radio Presets:</b> Press this submenu key to display the “<a href="#">Radio Presets Menu</a>” on page 2-68.</p>
<p>Back ←</p>	<p><b>Auto Detect:</b> Press this submenu key to display the “<a href="#">Auto Detect Menu</a>” on page 2-71.</p>
	<p><b>Back:</b> Returns to the “<a href="#">CPRI Config Menu</a>” on page 2-66.</p>

**Figure 2-78.** SFP Port Configuration Menu

## 2-26 Radio Presets Menu

Key Sequence: **Measurements** > CPRI Configure > SFP Port1 Config > Radio Presets

The same configuration menus are available for SFP Port 1 and Port 2.

Press one of the vendor-specific submenu keys to select a radio preset. To manually select individual parameter values, press the Custom Settings key.

**Alcatel UL/DL:** Press this key to select the radio preset for Nokia/ALU uplink/downlink.

**Ericsson:** Press this key to select a radio preset for Ericsson. Under the Ericsson menu (for Port 1 or Port 2) that opens, select the radio preset for uplink or downlink, as described in [“Ericsson Radio Preset Menu” on page 2-69](#).

**Huawei:** Press this key to select a radio preset for Huawei. Under the Huawei menu (for Port 1 or Port 2) that opens, select the radio preset for uplink or downlink, as described below.

**Samsung UL/DL:** Press this key to select the radio preset for Samsung uplink/downlink.

**No Preset:** Pressing this key turns off carrier aggregation. The current IQ Bit Width and Reserve Bit settings remain unchanged.

**Custom Settings:** Press this submenu key to display the [“Custom Settings Menu” on page 2-70](#), where you can specify custom settings for the IQ bit width and the number of reserve bits, turn CPRI aggregation on or off, and select the IQ mapping method. Use these settings when you do not have a specific vendor preset.

**Back:** Returns to the [“SFP Port Config Menu” on page 2-67](#).

**Huawei UL:** Selects the radio preset for Huawei uplink (RRH to BBU).

**Huawei DL:** Selects the radio preset for Huawei downlink (BBU to RRH).

**Back:** Returns to the [“Radio Presets Menu”](#).

**Figure 2-79.** Radio Presets Menu

The same configuration menus are available for SFP Port 1 and Port 2.

**Ericsson UL:** Press this key to select the radio preset for Ericsson uplink (RRH to BBU). Under the Ericsson Advanced menu (for Port 1 or Port 2) that opens, you can turn CPRI aggregation on or off and set the location of the start container, as described below.

**Ericsson DL:** Press this key to select the radio preset for Ericsson downlink (BBU to RRH). Under the Ericsson Advanced menu (for Port 1 or Port 2) that opens, you can turn CPRI aggregation on or off and set the location of the start container.

**Back:** Returns to the “Radio Presets Menu” on page 2-68.

**CPRI Aggregation**  
**Off On:** Press this submenu key to toggle CPRI aggregation Off or On. Refer to “CPRI Aggregation” on page 2-6.

**Reserve Containers**  
**Off On:** Turning this parameter on offsets the start location of the IQ data block to container number 4 in the CPRI stream. Container group AxC0 starts at container 0 (no offset) when this parameter is off.

To shift container group AxC0 to a specific location within the CPRI stream, set the Reserve Container Count under the “Custom Settings Menu”.

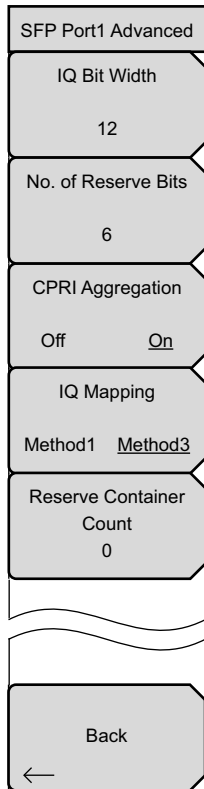
**Back:** Returns to the SFP Port Ericsson menu.

**Figure 2-80.** Ericsson Radio Preset Menu

## 2-27 Custom Settings Menu

Key Sequence: **Measurements** > CPRI Configure > SFP Port1 Config > Radio Presets > Custom Settings

The same configuration menus are available for SFP Port 1 and Port 2.



**IQ Bit Width:** Press this key to display the Select IQ Width list box. Selectable values are: 10, 12, 15, and 16. Use the touch screen, arrow keys, or rotary knob to highlight the desired IQ bit width, then press **Enter**.

**No. of Reserve Bits:** Press this submenu key, then use the numeric keypad, the arrow keys, or the rotary knob to set the number of reserve bits (or stuffing bits). The available range of values is 0 through 10. For LTE, 0 and 6 are common reserve bit values.

### CPRI Aggregation

**Off On:** Press this submenu key to toggle CPRI aggregation Off or On. Refer to [“CPRI Aggregation” on page 2-6](#).

### IQ Mapping

**Method1 Method3:** Press this submenu key to toggle between mapping methods 1 and 3. Refer to [“IQ Bit Mapping” on page 2-7](#).

**Reserve Container Count:** With most radio manufacturers, the IQ samples start at the beginning of the CPRI data flow. If your carrier uses a different frame structure, set this value to shift the start location of the IQ data block within the CPRI stream. For example, a Reserve Container Count of 4 will offset the location of container group AxCo to container number 4, skipping containers 0 through 3.

This parameter value overrides the Reserve Containers Off/On setting you may have chosen for your Ericsson radio preset.

**Back:** Returns to the [“Radio Presets Menu” on page 2-68](#).

**Figure 2-81.** Custom Settings Menu

## 2-28 Auto Detect Menu

Key Sequence: **Measurements** > CPRI Configure > SFP Port1 Config > Auto Detect

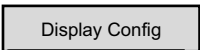


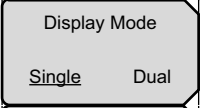
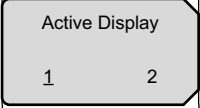
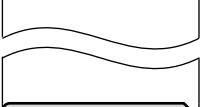
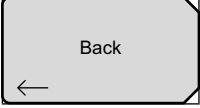
The same configuration menus are available for SFP Port 1 and Port 2.

SFP Port1 Auto Detect	<p><b>Radio Preset:</b> Press this submenu key to display the drop-down list of presets, then use the <b>Up/Down</b> arrow keys or the rotary knob or press the touch screen to make the selection.</p>
Radio Preset	<ul style="list-style-type: none"> <li>Custom Settings</li> <li>Ericsson UL</li> <li>Ericsson DL</li> <li>Alcatel UL</li> <li>Alcatel DL</li> <li>Huawei UL</li> <li>Huawei DL</li> <li>Samsung UL</li> <li>Samsung DL</li> </ul>
IQ Bit Width	<p><b>IQ Bit Width:</b> Press this submenu key to display the drop-down list of selectable bit widths: 10, 12, 15, or 16. This parameter can be changed only when Custom Settings, and not a vendor-specific preset, is selected as the Radio Preset value.</p>
Reserve Bits	<p><b>Reserve Bits:</b> Press this submenu key, then use the rotary knob or the <b>Up/Down</b> arrow keys to set the number of reserve bits, from 0 to 10. For LTE, 0 and 6 are the most common reserve bit values. This parameter can be changed only when Custom Settings is selected as the Radio Preset value.</p>
CPRI Aggregation	<p><b>CPRI Aggregation:</b> Press this submenu key, then use the rotary knob or the <b>Up/Down</b> arrow keys to set the Aggregation parameter On or Off.</p> <p>This parameter can be changed only when Custom Settings or Ericsson UL or Ericsson DL is selected as the Radio Preset value.</p>
Start	<p><b>Start Auto Detect:</b> After you have either selected a Radio Preset or entered custom settings for IQ Bit Width, Reserve Bits, and Aggregation, press this submenu key to initiate automatic detection of a matching CPRI signal. Refer to <a href="#">“CPRI Parameter Automatic Detection” on page 2-8</a>.</p>
Auto Detect	<p><b>Back:</b> Returns to the <a href="#">“SFP Port Config Menu” on page 2-67</a>.</p>
Back	

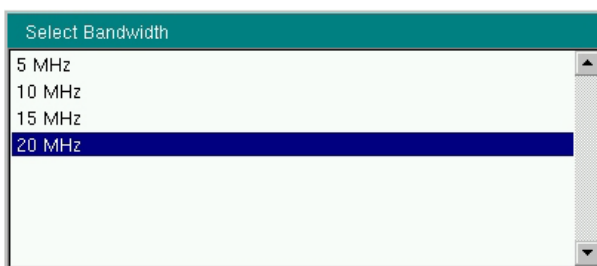
**Figure 2-82.** Auto Detect Menu

## 2-29 Display Config Menu

Key Sequence: **Measurements** > CPRI Configure > Display Config

	<p><b>Display 1 CPRI BW:</b> This is the LTE carrier bandwidth for Display 1. Press this key to display the Select Bandwidth list box illustrated in <a href="#">Figure 2-84</a>. Use the touch screen, arrow keys, or rotary knob to highlight the LTE carrier bandwidth, then press <b>Enter</b>. Selectable values are 5 MHz, 10 MHz, 15 MHz, and 20 MHz.</p>
	<p>If the bandwidth (such as 10 MHz) is displayed in red on the menu key label, you can use the arrow keys or rotary knob to change the value, then press <b>Enter</b>.</p>
	<p><b>Display 2 CPRI BW:</b> This is the LTE carrier bandwidth for Display 2, applied in dual display mode. Press this key to display the Select Bandwidth list box illustrated in <a href="#">Figure 2-84</a>. Use the touch screen, arrow keys, or rotary knob to highlight the LTE carrier bandwidth, then press <b>Enter</b>. Selectable values are 5 MHz, 10 MHz, 15 MHz, and 20 MHz.</p>
	<p><b>Display Mode</b>  <b>Single Dual:</b> Press this key to toggle between single and dual display mode. Up to four traces can be displayed on a single display, or they may be distributed between the two displays in dual display mode, as illustrated in <a href="#">Figure 2-87 on page 2-74</a>.</p>
	<p>When switching from dual to single mode, the currently active display, as selected by the Active Display key, below, will be shown as the single display.</p>
	<p><b>Active Display</b>  <b>1 2:</b> This key is active only in dual display mode. Press the key to toggle between Display 1 and 2. The currently active display is highlighted with a red border. See <a href="#">Figure 2-87 on page 2-74</a>. Settings under the following menus apply to the active display only:</p>
	<p>Frequency          Amplitude          Bandwidth          Limit</p> <p><b>Back:</b> Returns to the “CPRI Config Menu” on page 2-66.</p>

**Figure 2-83.** Display Config Menu



**Figure 2-84.** Select Display CPRI Bandwidth

## 2-30 AxC Trace Config Menu

Key Sequence: **Measurements** > CPRI Configure > AxC Trace Config

The diagram illustrates the AxC Trace Config Menu. The main menu (top) includes options for AxC Trace 1, 2, 3, and 4, each with a right-pointing arrow, and a Back option with a left-pointing arrow. The AxC Trace 1 sub-menu (bottom) includes options for Display (Off, 1, 2), SFP Port Selection (Port1, Port2), AxC Group (0), and Sampling Rate (Default, Compress), each with a right-pointing arrow, and a Back option with a left-pointing arrow. Arrows indicate the flow from the main menu to the sub-menu and back.

**AxC Trace 1:** Press this key to open the AxC Trace menu shown on the lower left of this page.  
The same configuration menu is available for each of the four possible AxC traces.

**Back:** Returns to the “CPRI Config Menu” on page 2-66.

**Display:** Press this key to select which display, 1 or 2, will show the current trace. Off turns off the trace.

**SFP Port Selection:** On models with two SFP ports, press this submenu key to toggle between SFP Port 1 and Port 2, depending on which CPRI signal you wish to measure.

**AxC Group:** Press this submenu key, then use the rotary knob, the arrow keys, or the numeric keypad to select the AxC group. The AxC group numbers associated with the possible four traces are shown on the top left of the instrument screen.

**Sampling Rate:** This key is active only when the selected display bandwidth is 20 MHz. If the radio equipment manufacturer has applied undersampling to carry the 20 MHz bandwidth signal in 6 containers rather than 8, choose the Compress setting to display the signal as a full 20 MHz signal. This feature is available with firmware version 2.6 and later.

**Back:** Returns to the “AxC Trace Config Menu”.

**Figure 2-85.** AxC Trace Config Menu

## 2-31 CPRI Spectrum Menu

Key Sequence: **Measurements** > CPRI Spectrum

If the previously selected measurement display mode was Spectrogram, press the CPRI Spectrum key a second time to display the menu below.

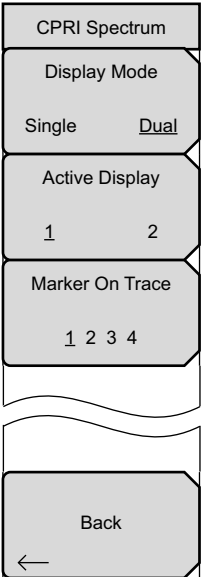
	<p><b>Display Mode</b>  <b>Single Dual:</b> Press this key to toggle between single and dual display mode. Up to four traces can be displayed on a single display, or they may be distributed between the two displays in dual display mode, as illustrated in <a href="#">Figure 2-87</a>.</p> <p>When switching from dual to single mode, the currently active display, as selected by the Active Display key described below, will be shown as the single display.</p> <p><b>Active Display</b>  <b>1 2:</b> This key is active only in dual display mode. Press the key to toggle between Display 1 and 2. The currently active display is highlighted with a red border. See <a href="#">Figure 2-87</a>. Settings under the following menus apply to the active display only: Frequency, Amplitude, Bandwidth, Limit.</p> <p><b>Marker On Trace</b>  <b>1 2 3 4:</b> Press this key to select the AxC trace to which markers are applied. Markers are activated on one trace at a time.</p> <p><b>Back:</b> Returns to the “<a href="#">Measure Menu</a>” on page 2-53.</p>
--	---

Figure 2-86. CPRI Spectrum Menu

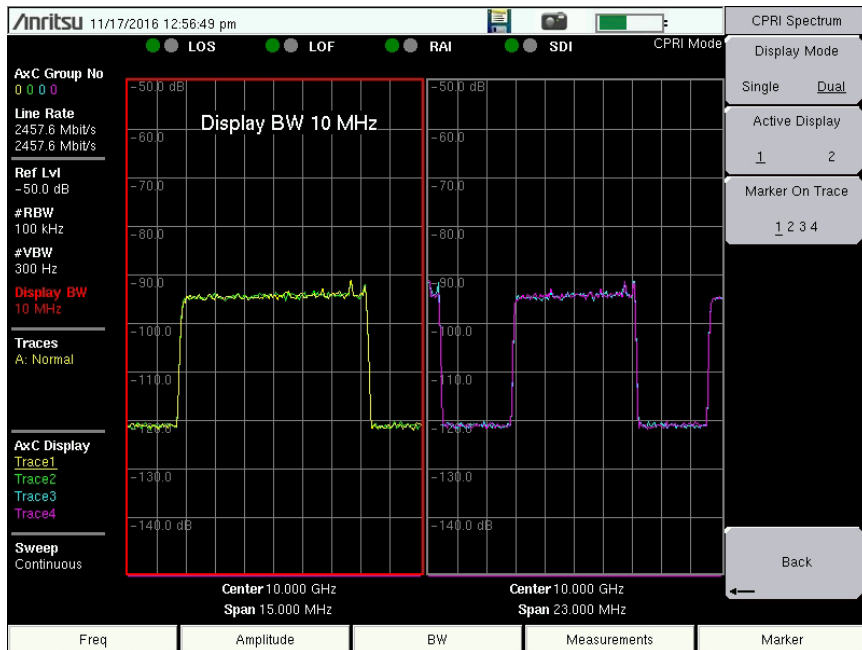


Figure 2-87. Spectrum Dual Display

## 2-32 Spectrogram Menu

Key Sequence: **Measurements** > Spectrogram

Spectrogram	<b>Sweep Interval:</b> Press this key, then use the numeric keypad, the arrow keys, or the rotary knob to set the sweep interval in min, s, ms, or $\mu$ s. The Auto setting is equivalent to a zero value. The currently active trace must be set to Max Hold, Min Hold, or Average for the sweep interval to have an effect.
Sweep Interval Auto	<b>Record</b> <b>On Off:</b> Press this key to start (On) or cancel (Off) recording. When turning on recording, measurement data is recorded for the specified Recording Time, then saved in internal memory in a date and time labeled folder. The file name is of the form CPRI_SPGYyyyymmddhhmmss.cpri.
Record On Off	The Record setting automatically turns off at the end of the timed measurement.
Recording Time 1 min	<b>Recording Time:</b> Sets the recording time in units of hour, min, s, ms, or $\mu$ s. One minute is the minimum time setting, and it is the default setting when Record is set to on. This key is displayed only when Record is set to on.
Time Cursor 0	<b>Time Cursor:</b> Press this key, then use the numeric keypad, the arrow keys, or the rotary knob to set the time cursor value. This setting enables time tracking for the intermittent interference signals. The current measurement is stopped when the time cursor value is not zero.
Reset/ Restart Measurement	<b>Reset/Restart Measurement:</b> Clears the display and restarts the measurement.
Display Setup →	<b>Display Setup:</b> Opens the <a href="#">“Display Setup Menu” on page 2-76</a> .
Back ←	<b>Back:</b> Returns to the <a href="#">“Measure Menu” on page 2-53</a> or to the <a href="#">“BBU RF Test Menu” on page 2-61</a> .

**Figure 2-88.** Spectrogram Menu

## 2-33 Display Setup Menu

Key Sequence: **Measurements** > Spectrogram > Display Setup

Display Setup	<b>Display Mode</b>
Display Mode Single <u>Dual</u>	<b>Single Dual:</b> Press this key to toggle between single and dual display mode. In spectrogram view, only one trace at a time can be displayed as a waterfall measurement, one on each display in dual mode, as illustrated in <a href="#">Figure 2-91 on page 2-77</a> .
Active Display 1            2	When switching from dual to single mode, the currently active display, as selected by the Active Display key described below, will be shown as the single display.
Marker On Trace 1 2 3 4	<b>Active Display</b> <b>1 2:</b> This key is active only in dual display mode. Press the key to toggle between Display 1 and 2. The currently active display is highlighted with a red border. Settings under the following menus apply to the active display only:
Display 1 AxC Trace 1	Frequency Amplitude Bandwidth Limit
Display 2 AxC Trace 3	<b>Marker On Trace</b> <b>1 2 3 4:</b> Press this key to select the AxC trace to which markers are applied. Markers are activated on one trace at a time.
Back ←	<b>Display 1 AxC Trace:</b> Press this key to open the Select Trace list box illustrated in <a href="#">Figure 2-90</a> . Use the touch screen, rotary knob or arrow keys to highlight a trace number in the list, then press <b>Enter</b> . The selected AxC trace will be the one displayed on Spectrogram Display 1 and the trace number is shown on the key label.
	If no trace has been configured for Display 1, the Display 1 AxC Trace key label displays N/A in place of the trace number and the Select Trace list box will show “No AxC Trace Configured.”
	<b>Display 2 AxC Trace:</b> This key is active only in dual display mode. Press the key to open the Select Trace list box illustrated in <a href="#">Figure 2-90</a> . Use the touch screen, rotary knob or arrow keys to highlight a trace number in the list, then press <b>Enter</b> . The selected AxC trace will be the one displayed on Spectrogram Display 2 and the trace number is shown on the key label.
	If no trace has been configured for Display 2, the Display 2 AxC Trace key label displays N/A in place of the trace number and the Select Trace list box will show “No AxC Trace Configured.”
	In <a href="#">Figure 2-91</a> , the AxC Trace information on the left of the instrument screen indicates Display 1 is showing Trace 1, Display 2 is showing Trace 3.
	<b>Back:</b> Returns to the <a href="#">“Spectrogram Menu” on page 2-75</a> .

**Figure 2-89.** Spectrogram Display Setup Menu

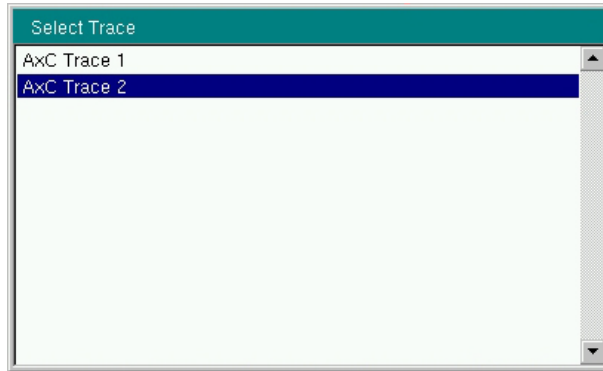


Figure 2-90. Select Trace List Box

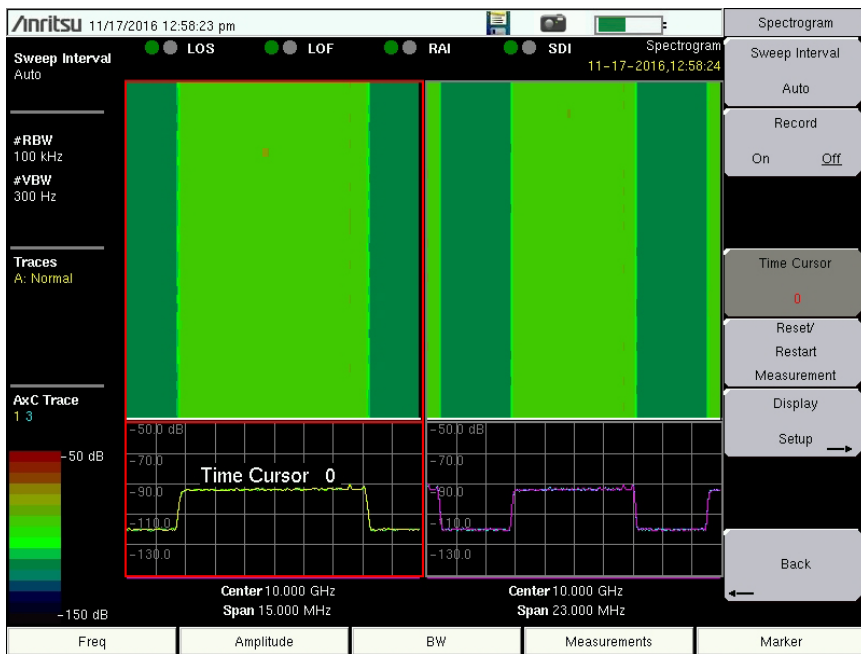
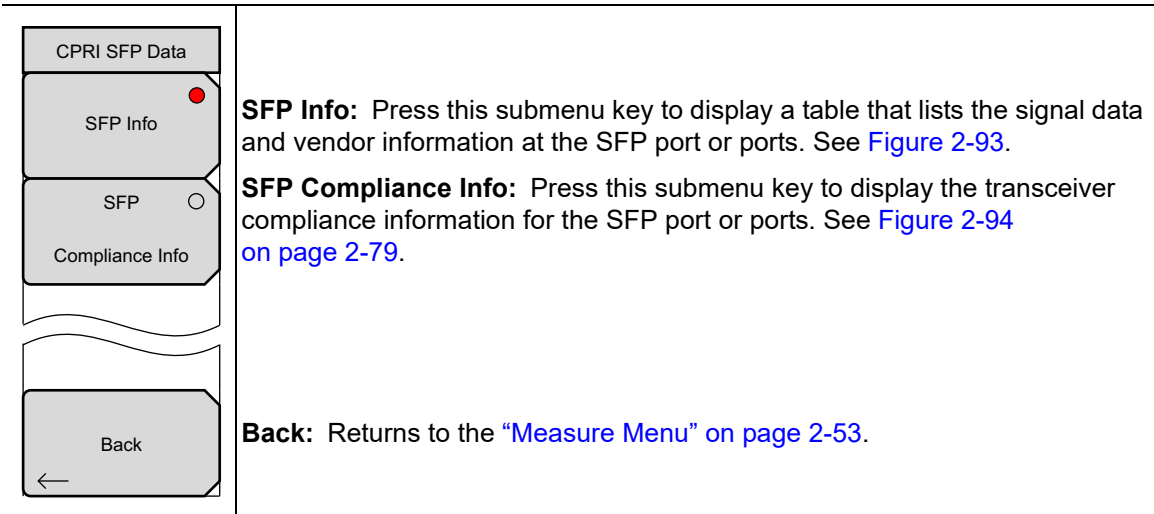


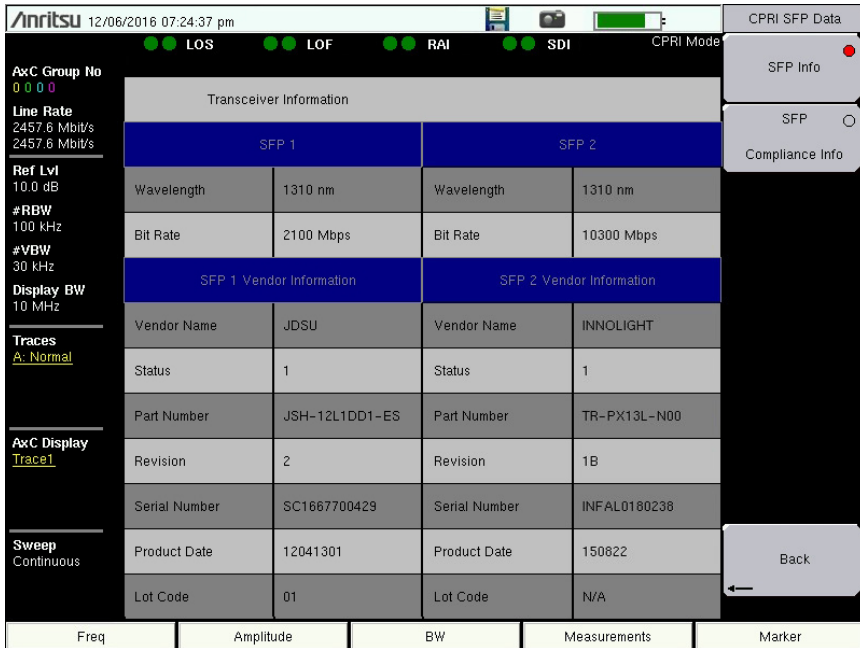
Figure 2-91. Spectrogram Dual Display

## 2-34 CPRI SFP Data Menu

Key Sequence: **Measurements** > SFP Data



**Figure 2-92.** CPRI SFP Data Menu



**Figure 2-93.** SFP Info Screen (Dual-Port Model)

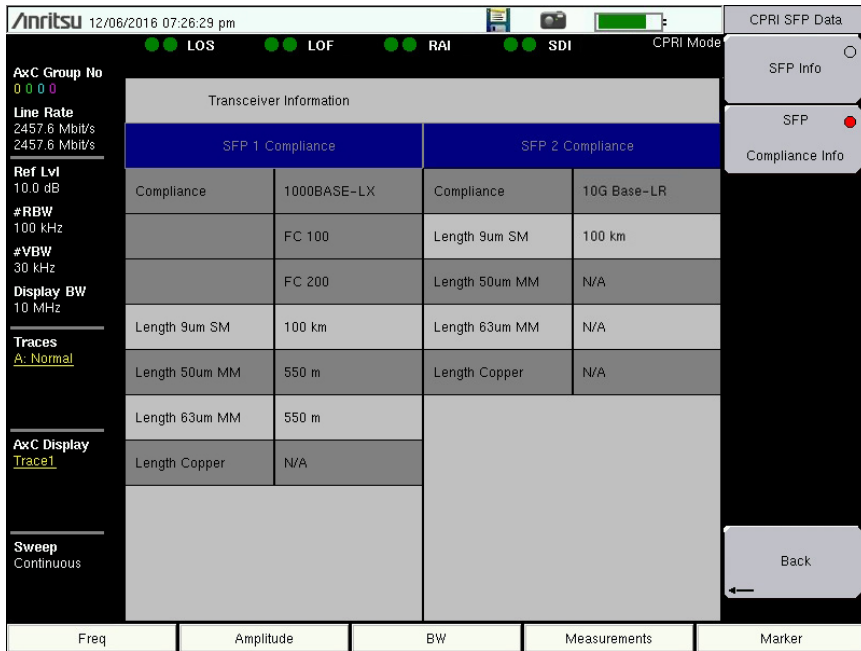
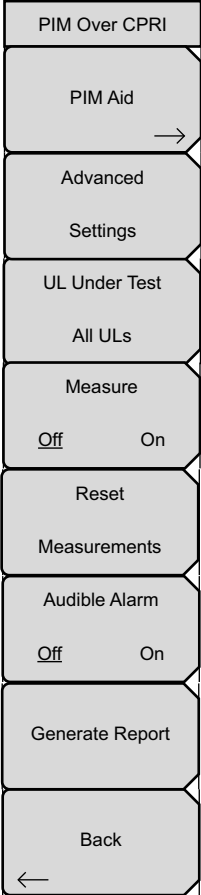


Figure 2-94. SFP Compliance Info Screen (Dual-Port Model)

## 2-35 PIM Over CPRI Menu (Option 754 Only)

Key Sequence: **Measurements** > PIM Over CPRI

	<p><b>PIM Aid:</b> This key opens the PIM Aid window illustrated in <a href="#">Figure 2-34 on page 2-31</a>. Selectable parameters are described in “<a href="#">PIM Over CPRI Configuration Settings</a>”.</p> <p><b>Advanced Settings:</b> Press this key to open the dialog shown in <a href="#">Figure 2-96</a>.</p> <p><b>PIM Desensitization Limit:</b> Enter a limit value for the acceptable noise floor level. A measurement that exceeds this threshold will result in a Fail status and trigger the alarm.</p> <p><b>Radio Noise Figure:</b> This is the radio noise figure of the receiver. The default is 2.0 dB.</p> <p><b>Thermal Noise Floor:</b> Enter the thermal noise floor of the RRH as specified by the radio manufacturer. The default is -64.40 dBFS.</p> <p><b>Bandwidth:</b> Press the appropriate field to apply either the uplink bandwidth or the CPRI bandwidth specified by the radio manufacturer: 5 MHz, 10 MHz, 15 MHz, or 20 MHz.</p> <p><b>Results Units:</b> Measurement results can be displayed in dBm or dBFS.</p> <p><b>Save and Exit:</b> Saves your changes and closes the dialog.</p> <p><b>UL Under Test:</b> When the site configuration is 2x2 or 2x4 MIMO, you can choose to measure only one uplink. To do so, press this key and select the UL number in the UL Under Test selection list. See <a href="#">Figure 2-97</a>. “Cycle through All ULs” will measure all available uplinks one at a time.</p> <p>The UL Under Test can also be selected in the PIM Aid dialog.</p> <p><b>Measure Off/On:</b> Press this key to stop and start measurements. The setting is on after you press “Save and Measure” in the PIM Aid configuration dialog.</p> <p><b>Reset Measurements:</b> Stops current measurements and clears all data from the results table. The most recently saved settings in the PIM Aid configuration window are retained.</p> <p><b>Audible Alarm Off/On:</b> Press this key to toggle the audible alarm off and on. If on, the alarm will sound when a measurement fails.</p> <p><b>Generate Report:</b> Press this key to generate a PIM measurement report. In the virtual keyboard screen that opens, enter a report file name. Two files are created for each measured uplink: a measurement results file (extension .cpri) and a screen capture (.jpg) of the PIM over CPRI spectrum display:</p> <pre>filename_ULx_MMDDYY_HHMMSS.cpri filename_ULx_MMDDYY_HHMMSS.jpg</pre> <p>If “Cycle through All ULs” is selected, the number of generated files depends on the site configuration: two for SISO, four for 2x2 MIMO, eight for 2x4 MIMO.</p> <p><b>Back:</b> Returns to the “<a href="#">Measure Menu</a>” on <a href="#">page 2-53</a>.</p>
---	--

**Figure 2-95.** PIM Over CPRI Menu

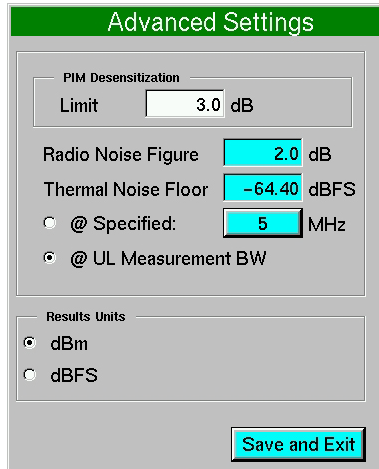


Figure 2-96. PIM Over CPRI Advanced Settings

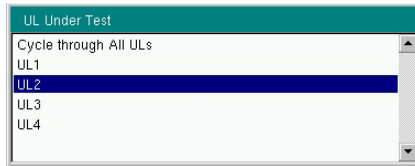


Figure 2-97. Uplink Under Test Selection List

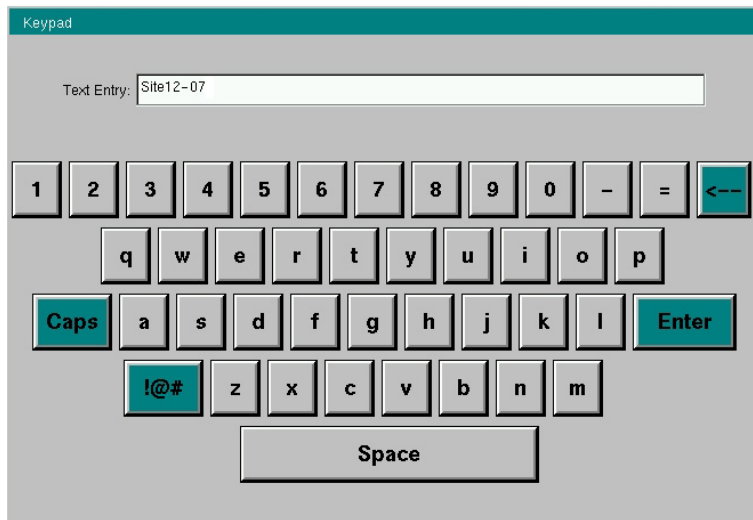
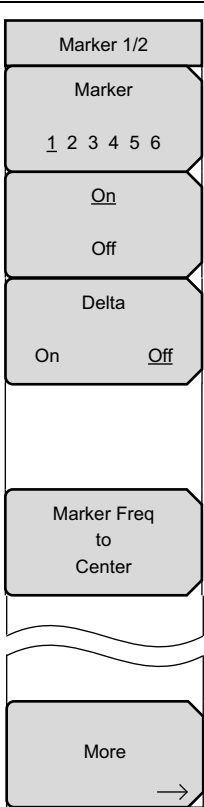


Figure 2-98. Virtual Keyboard

## 2-36 Marker Menu

Marker settings apply to the currently selected AxC trace. Press the **Marker** main menu key to open the Marker 1/2 menu. Up to 6 markers may be set, but only on one trace at a time. Use the arrow keys to change marker frequency.

Key Sequence: **Marker**



**Marker:** Press this key to display the Select Marker box illustrated in [Figure 2-100](#), then press a marker number (M1 to M6) to make the marker active and turn it on. The selected marker number is underlined on the Marker menu key.

The key sequence is different if your Anritsu instrument is not a touch screen model. Refer to your instrument User Guide.

**On/Off:** Turns on or off the currently active marker. When on, the active marker is highlighted in red. See [Figure 2-101 on page 2-83](#).

**Delta On/Off:** Turns on a delta marker. Use the numeric keypad to enter an offset value from the frequency of the currently active marker. Press the +/- key to enter a negative offset. In [Figure 2-102 on page 2-83](#), the delta marker is set at -3 MHz from Marker 2.

**Marker Freq to Center:** Moves the frequency noted by the active marker to the center frequency position and center of the display.

**More:** Opens a submenu of additional Marker options. See the [“Marker 2/2 Menu” on page 2-84](#).

Figure 2-99. Marker 1/2 Menu

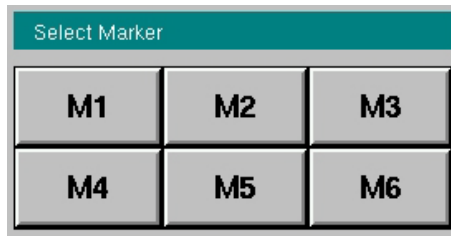


Figure 2-100. Select Marker (instrument models with touch screen)

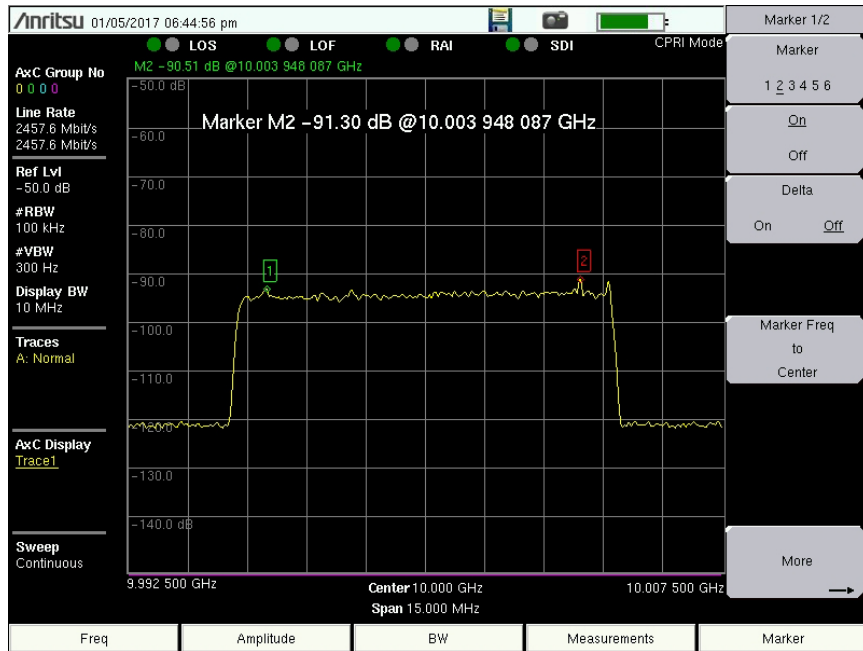


Figure 2-101.Active Marker M2

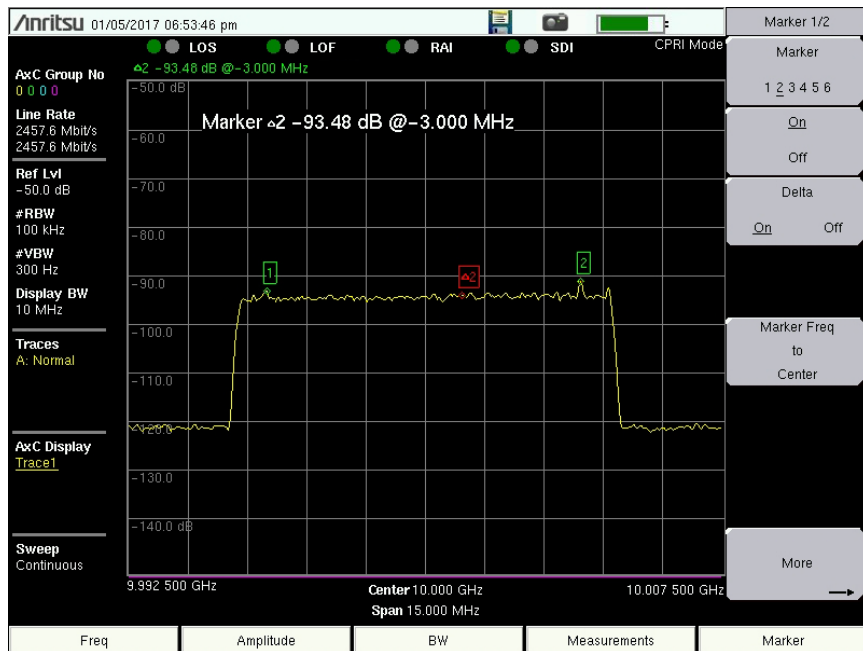


Figure 2-102.Delta Marker 2

## 2-37 Marker 2/2 Menu

Key Sequence: **Marker** > More

Marker 2/2	<p><b>Marker Table</b>  <b>On Large Off:</b> Press this key to enable or disable the marker table. When set to On, a table showing the frequency and amplitude levels for each marker is displayed below the sweep window. The table is automatically sized to list all markers that are turned on. If Large is selected, the currently active marker's amplitude and frequency will be displayed in large type below the sweep window. See <a href="#">Figure 2-104</a>.</p> <p><b>All Markers Off:</b> Turns off all markers.</p> <p><b>Back:</b> Returns to the "Marker Menu" on page 2-82.</p>
Marker Table On Large <u>Off</u>	
All Markers Off	
Back ←	

Figure 2-103. Marker 2/2 Menu

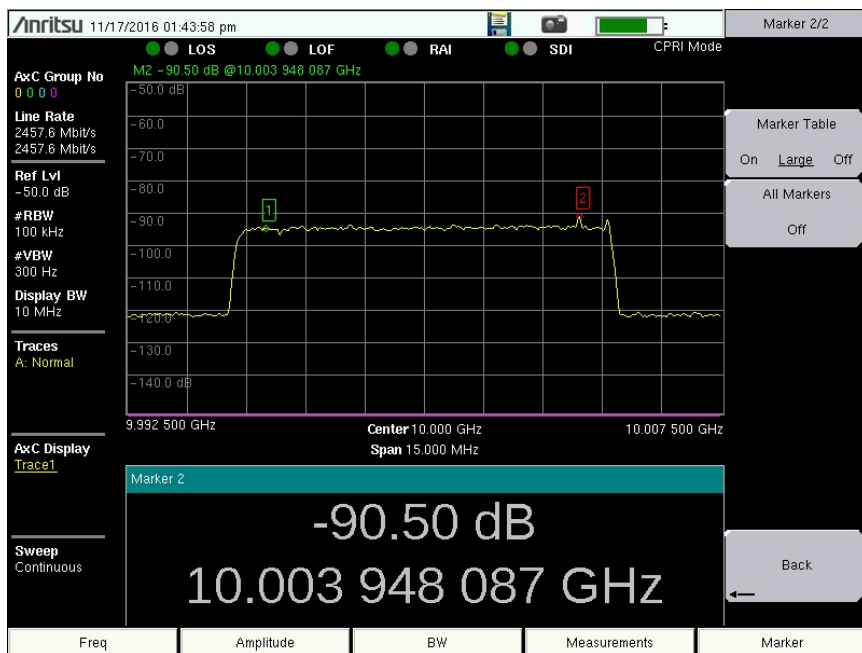


Figure 2-104. Marker Table - Large

## 2-38 Sweep Menu

Key Sequence: **Shift > Sweep (3)**

Sweep	<p><b>Sweep Single/Continuous:</b> This submenu key toggles between continuous sweep and single sweep. In single sweep mode, the results of a sweep are displayed on the screen while the instrument awaits a trigger event to start a new sweep.</p> <p><b>Sweep Once:</b> When Sweep is set to Single, Sweep Once triggers a single measurement sweep. This key has no function when the instrument is in continuous sweep mode.</p> <p><b>Sweep # Averages:</b> Sweeps the number of times set using the # of Averages button under the Trace A Ops menu. Trace A must be set to Averaging (<b>Shift &gt; Trace (5)</b> key &gt; Trace A Operations &gt; Average-&gt;A) for this menu to function. Each trace is displayed using the exponential average of each sweep.</p>
Sweep	
Single <u>Continuous</u>	
Sweep Once	
Sweep 10	
Averages	

**Figure 2-105.** Sweep Menu

## 2-39 Trace Menu

The instrument is capable of displaying up to three traces, one with live data, and the other two either with stored data or trace math data. These settings apply only to AxC Trace 1.

Key Sequence: **Shift > Trace (5)**

Trace	<p><b>Trace</b>  <b>A B C:</b> Sets trace A, B, or C as the active trace. Each press of this key increments through trace A, B, and C. The active trace is underlined.</p> <p><b>View/Blank:</b> Displays or hides the active trace.</p> <p><b>Write/Hold:</b> Selects between holding the current swept trace on the screen or continually sweeping and updating the displayed measurement. This is not applicable to Trace B or Trace C unless trace math involving Trace A is active.</p> <p><b>Trace A Operations:</b> Lists the Trace A Ops menu to select an operation that can be applied to Trace A. See <a href="#">“Trace A Ops Menu” on page 2-87</a>.</p> <p><b>Trace B Operations:</b> Lists the Trace B Ops menu to select an operation that can be applied to Trace B. See <a href="#">“Trace B Ops Menu” on page 2-88</a>.</p> <p><b>Trace C Operations:</b> Lists the Trace C Ops menu to select an operation that can be applied to Trace C. See <a href="#">“Trace C Ops Menu” on page 2-89</a>.</p> <p><b>Reset Trace:</b> Resets the trace averaging, Max Hold or Min Hold, and restarts the sweep.</p> <p><b>Trace Info:</b> Stops the current trace and displays a summary table of trace parameters and current settings. See <a href="#">Figure 2-107</a>. Press <b>Enter</b> or <b>Esc</b> to clear the table from the display and restart the trace.</p> <p><b>Display:</b> Press the appropriate key to display trace information for Trace A Only, Trace B Only, Trace C Only, or All Traces.</p> <p><b>Top of List:</b> Press this key to jump to the top of the Trace Info table.</p> <p><b>Page Up:</b> Press this key to skip up through the table.</p> <p><b>Page Down:</b> Press this key to skip down through the table.</p> <p><b>Bottom of List:</b> Press this key to jump to the bottom of the table.</p>
Trace	
<u>A</u> B C	
<u>View</u>	
Blank	
<u>Write</u>	
Hold	
Trace A	
Operations →	
Trace B	
Operations →	
Trace C	
Operations →	
Reset	
Trace	
Trace Info	

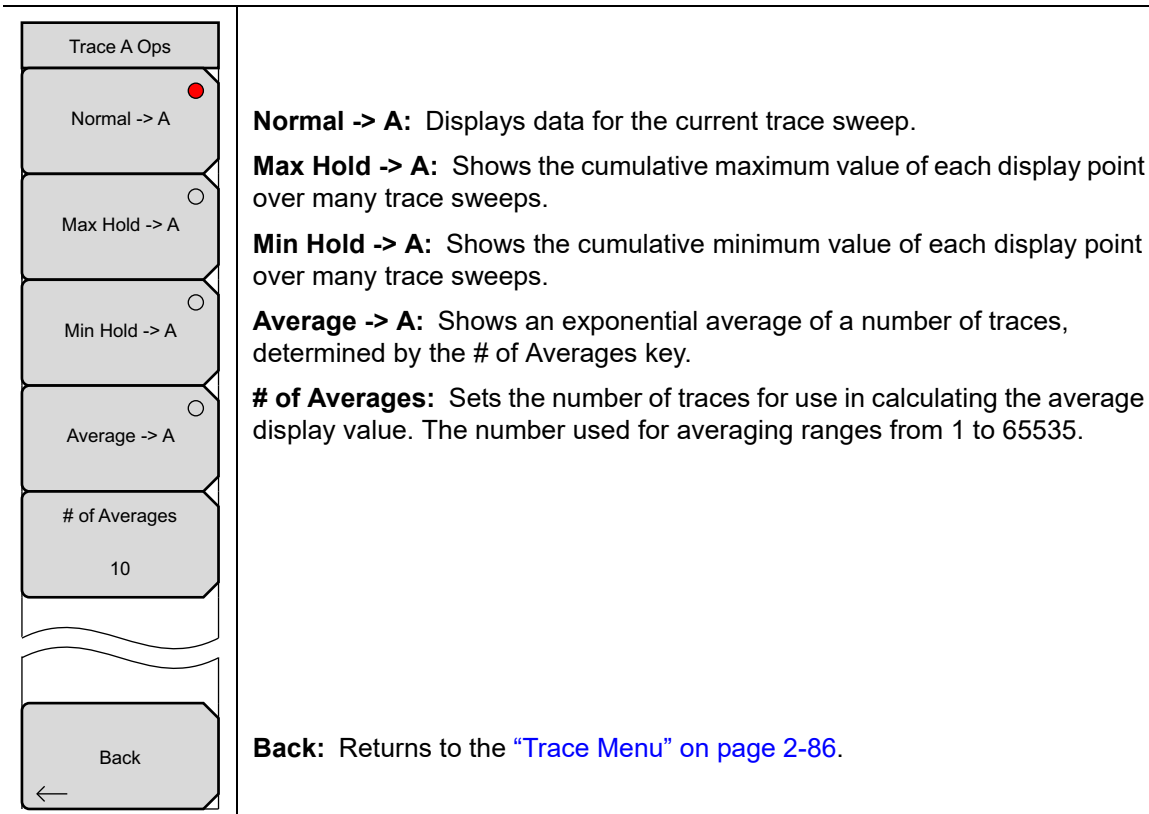
Figure 2-106. Trace Menu

Trace Info			
Setting	Trace A	Trace B	Trace C
Trace Mode	Normal	Trace Hold	Trace Hold
Center Freq	10.000 GHz	10.000 GHz	10.000 GHz
Current Channel	--	0	0
Span	15.000 MHz	15.000 MHz	15.000 MHz
Start Freq	9.992 500 GHz	9.992 500 GHz	9.992 500 GHz
Stop Freq	10.007 500 GHz	10.007 500 GHz	10.007 500 GHz
Ref Lvl	10.0 dB	10.0 dB	10.0 dB
Detection	Peak		
#RBW	30 kHz	30 kHz	30 kHz
#VBW	300 Hz	300 Hz	300 Hz
VBW/Avg Type	Linear		

Figure 2-107. Trace Info Message Box

## 2-40 Trace A Ops Menu

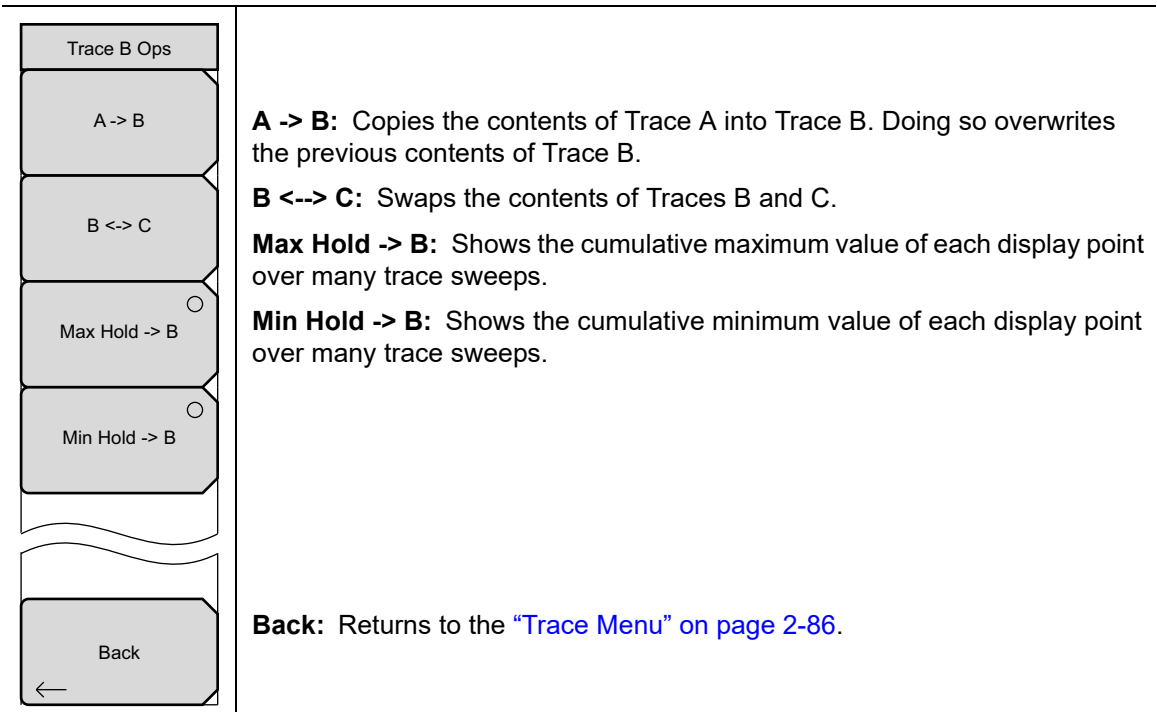
Key Sequence: **Shift** > **Trace (5)** > Trace A Operations



**Figure 2-108.** Trace A Ops Menu

## 2-41 Trace B Ops Menu

Key Sequence: **Shift > Trace (5) > Trace B Operations**



**Figure 2-109.** Trace B Ops Menu

## 2-42 Trace C Ops Menu

Key Sequence: **Shift** > **Trace (5)** > Trace C Operations

Trace C Ops	
A -> C	<b>A -&gt; C:</b> Copies the contents of Trace A into Trace C. Doing so overwrites the previous contents of Trace C.
B <-> C	<b>B &lt;-&gt; C:</b> Swaps the contents of Trace B and Trace C.
Max Hold -> C	<b>Max Hold -&gt; C:</b> Shows the cumulative maximum value of each display point over many trace sweeps.
Min Hold -> C	<b>Min Hold -&gt; C:</b> Shows the cumulative minimum value of each display point over many trace sweeps.
A-B -> C	<b>A - B -&gt; C:</b> Subtracts the value of Trace B from Trace A and places the results in Trace C. This function is very useful for observing the changes in values of live Trace A compared to a trace stored in Trace B.
B-A -> C	<b>B - A -&gt; C:</b> Subtracts the value of Trace A from Trace B and places the results in Trace C. This function is very useful for observing the changes in values of live Trace A compared to a trace stored in Trace B.
Relative Ref	When trace math is active, a relative scale shows on the right side of the graph, and is associated to Trace C. This allows the user to optimize the display of Trace C without affecting the display of Trace A and Trace B.
10.0 dB	<b>Relative Ref:</b> Sets the value applied to the top graticule for the relative scale that appears on the right side of the graph when trace math is active. Change this value by using the rotary knob, up or down arrows, or entering the value on the numeric keypad and pressing the dB submenu key or the <b>Enter</b> key. This entry is valid only when trace math is active.
Relative Scale	<b>Relative Scale:</b> Sets the value applied to the scaling of the relative scale that appears on the right side of the graph when trace math is active. Change this value by using the rotary knob, up or down arrows, or entering the value on the numeric keypad and pressing the dB submenu key or the <b>Enter</b> key. This entry is valid only when trace math is active.
10 dB/div	<b>Back:</b> Returns to the <a href="#">"Trace Menu"</a> on page 2-86.

**Figure 2-110.** Trace C Ops Menu

## 2-43 Limit Menu

In Spectrum view, limit lines may be used for visual reference only or as pass/fail criteria in triggering a limit alarm. You can configure an upper and a lower limit. Each limit is a flat (non-segmented) line that can trigger an alarm whenever any signal data point exceeds the set amplitude limit, when the Limit Alarm setting is set to on.

In dual display mode, the limit settings apply to the currently active display, Display 1 or 2, as denoted in the Limit menu heading. See [Figure 2-111](#).

Key Sequence: **Shift > Limit (6)**

Display 1 Limit	
Limit	<b>Limit</b>
Upper Lower	<b>Upper Lower:</b> Press this key to toggle between configuring either the upper or the lower limit (that is, make it active).
On	<b>On/Off:</b> Turns on or off the active limit line (upper or lower). See <a href="#">Figure 2-113 on page 2-91</a> .
Off	
Limit Move	<b>Limit Move:</b> Opens the “ <a href="#">Limit Move Menu</a> ” on page 2-91.
Save Limit	<b>Save Limit:</b> Opens the “ <a href="#">Save Menu</a> ” on page 2-92 and displays a dialog to save the currently active limit line. You can enter a name for the saved limit line or apply the name suggested by the instrument (which is based on a previously saved name). Press <b>Esc</b> to cancel the save operation.
Recall Limit	<b>Recall Limit:</b> Opens the “ <a href="#">Recall Menu</a> ” on page 2-96 and displays a dialog to recall a saved limit line. In the Recall dialog box, navigate to a previously saved limit line file and press <b>Enter</b> to recall. Press <b>Esc</b> to cancel.
Limit Alarm	<b>Limit Alarm</b>
On Off	<b>On Off:</b> Press this key to turn on and off the alarm function for the currently active limit line. When on, an alarm beep will sound when any data point exceeds the limit.
Set Default Limit	<b>Set Default Limit:</b> Turns on the currently active limit line and places it at its default position in the sweep window. For the upper limit line, this is two and a half divisions below the top of the grid (or amplitude reference level). The lower limit line default position is two and a half divisions above the bottom of the sweep window.

**Figure 2-111.** Limit Menu

## 2-44 Limit Move Menu

Key Sequence: **Shift** > **Limit (6)** > Limit Move

<div style="border: 1px solid black; padding: 5px; margin-bottom: 5px;">Display 1 Limit Move</div> <div style="border: 1px solid black; padding: 5px; margin-bottom: 5px;">Move Limit U/D 0.0 dB</div> <div style="border: 1px solid black; padding: 5px; margin-bottom: 5px;">Limit Amplitude  -90.0 dB</div> <div style="border: 1px solid black; padding: 5px; margin-bottom: 5px;">Back  ←</div>	<p><b>Move Limit U/D:</b> Press this key and use the rotary knob to adjust the limit amplitude up or down. Use the numeric keypad to enter the distance by which to move the limit, either up or down, from its current amplitude. For example, entering -5 dB will move the current limit line downward 5 dB from its current amplitude.</p> <p><b>Limit Amplitude:</b> Press this key and set the amplitude of the currently active limit line using the rotary knob or numeric keypad. If using the keypad, press the +/- key for a negative value and press the dB key or <b>Enter</b> to set.</p> <p><b>Back:</b> Returns to the “Limit Menu” on page 2-90.</p>
--	--

Figure 2-112. Limit Move Menu

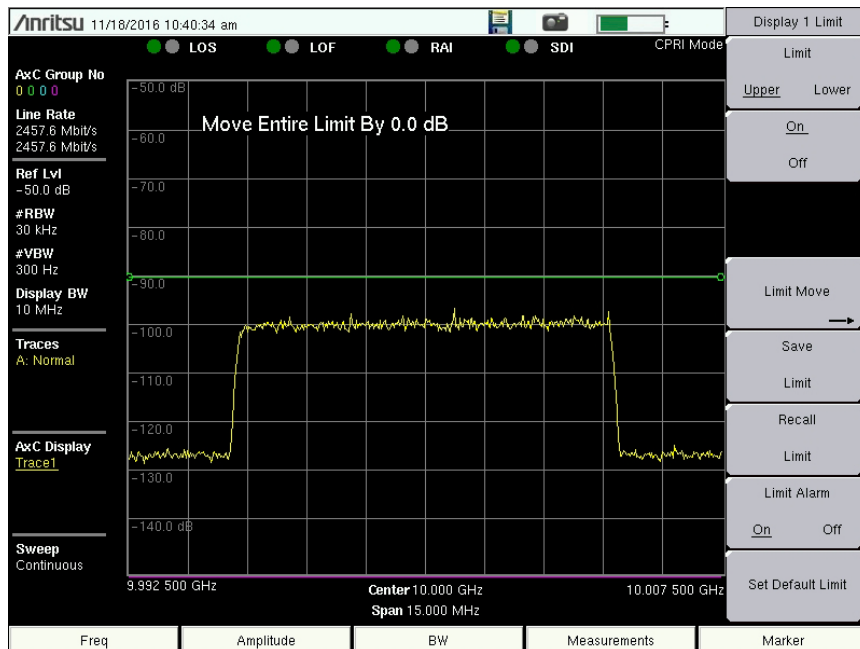


Figure 2-113. Limit Line Example

## 2-45 Save Menu

Key Sequence: **Shift > Limit (6) > Save Limit**

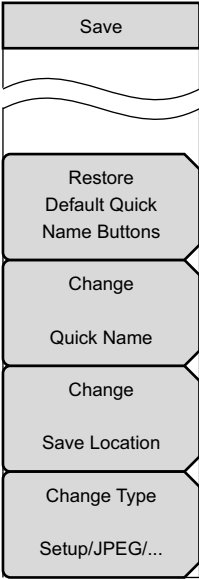
	<p>Use the touch screen keyboard illustrated in <a href="#">Figure 2-115</a> to type the desired file name in the Filename edit box. Optionally, you can use the Quick Name keys to insert preset text strings into the file name.</p> <p>Press <b>Enter</b> to save, <b>Esc</b> to close the Save dialog without saving.</p> <p><b>Restore Default Quick Name Buttons:</b> Press this key to reset to their factory defaults any custom Quick Names previously defined. Press Yes in the confirmation dialog to proceed.</p> <p><b>Change Quick Name:</b> Press this key to define a custom text string associated with one of the Quick Name buttons at the bottom of the touch screen keyboard (see <a href="#">Figure 2-115</a>). Select the Quick Name to edit as illustrated in <a href="#">Figure 2-116</a>, then press <b>Enter</b>. In the Edit Quick Name dialog, type the new Quick Name and press <b>Enter</b> again. See <a href="#">Figure 2-117</a>. The new Quick Name is displayed on the button below the keyboard.</p> <p><b>Change Save Location:</b> Opens the <a href="#">“Save Location Menu”</a> on page 2-94.</p> <p><b>Change Type Setup/JPEG/...</b> Press this key if you want to save data other than limit lines.</p>
--	---

Figure 2-114. Save Menu

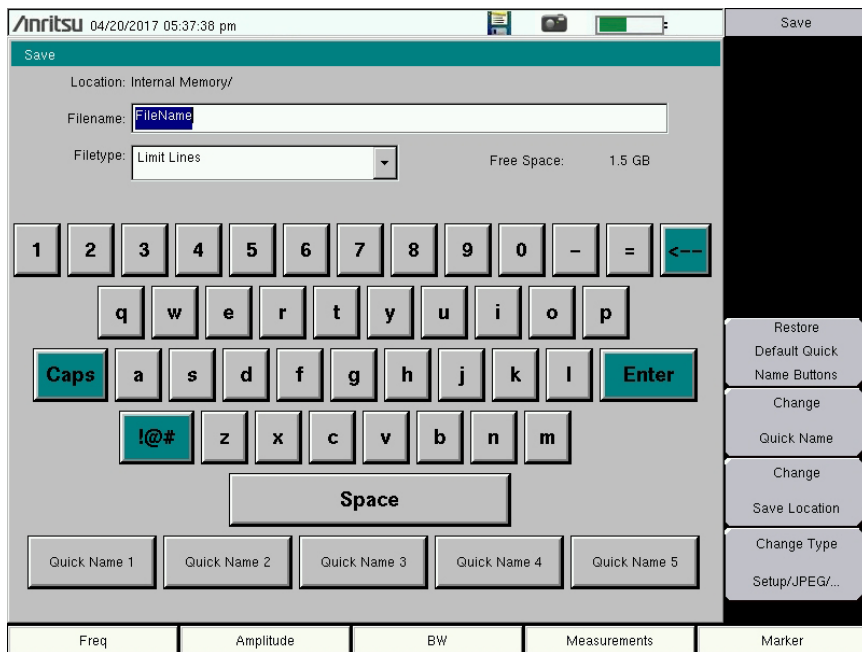


Figure 2-115. Save Dialog

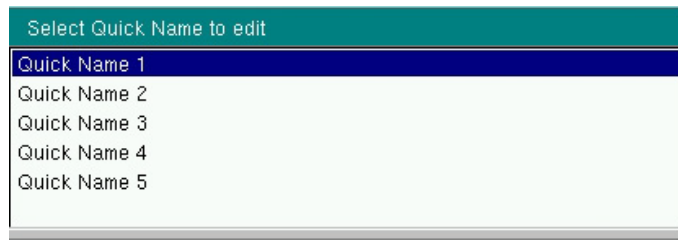


Figure 2-116. Select Quick Name List Box

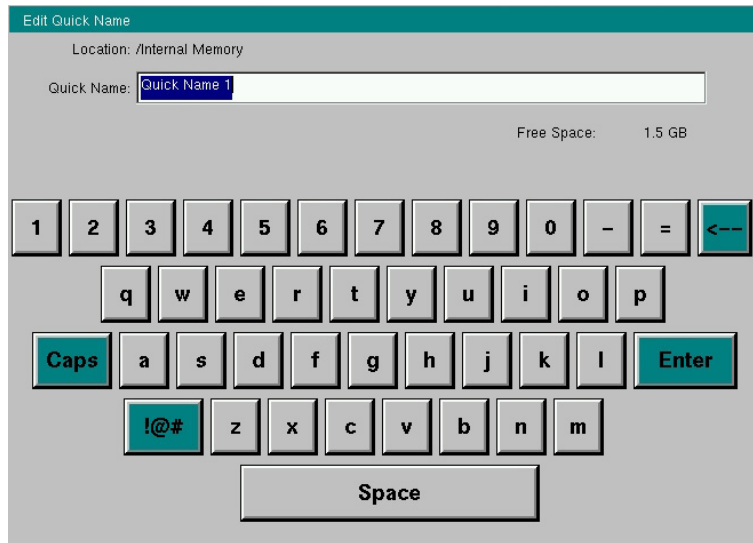


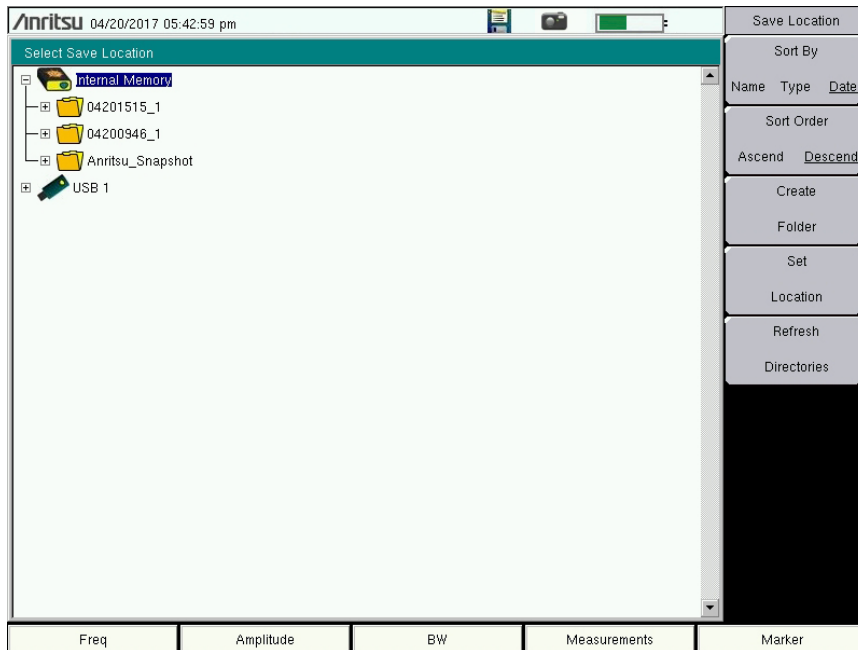
Figure 2-117. Edit Quick Name Dialog

## 2-46 Save Location Menu

Key Sequence: **Shift > Limit (6) > Save Limit > Change Save Location**

<div style="border: 1px solid black; padding: 5px; margin-bottom: 5px;">Save Location</div> <div style="border: 1px solid black; padding: 5px; margin-bottom: 5px;">Sort By Name Type Date</div> <div style="border: 1px solid black; padding: 5px; margin-bottom: 5px;">Sort Order Ascend Descend</div> <div style="border: 1px solid black; padding: 5px; margin-bottom: 5px;">Create Folder</div> <div style="border: 1px solid black; padding: 5px; margin-bottom: 5px;">Set Location</div> <div style="border: 1px solid black; padding: 5px;">Refresh Directories</div>	<p>You can save files to internal memory or a USB storage device. Use the touch screen, Up/Down arrow keys, or rotary knob to select the folder, then press Set Location.</p> <p><b>Sort By</b> <b>Name Type Date:</b> Press this key to choose the item by which folders are sorted in the Select Save Location list. See <a href="#">Figure 2-119</a>.</p> <p><b>Sort Order</b> <b>Ascend Descend:</b> Toggles the sort order of the folder list between Ascending and Descending.</p> <p><b>Create Folder:</b> Press this key to create a new folder inside the selected directory. Enter the new folder name in the Create Directory dialog and press <b>Enter</b> (see <a href="#">Figure 2-120 on page 2-95</a>). To return to the Select Save Location dialog without creating a new folder, press <b>Esc</b>.</p> <p><b>Set Location:</b> Press this key to set the currently selected folder as the destination where saved files will be stored, and to return to the <a href="#">“Save Menu” on page 2-92</a>.</p> <p><b>Refresh Directories:</b> Press this key to update the folder list after connecting or disconnecting an external USB device.</p>
---	---

**Figure 2-118.** Save Location Menu



**Figure 2-119.** Select Save Location

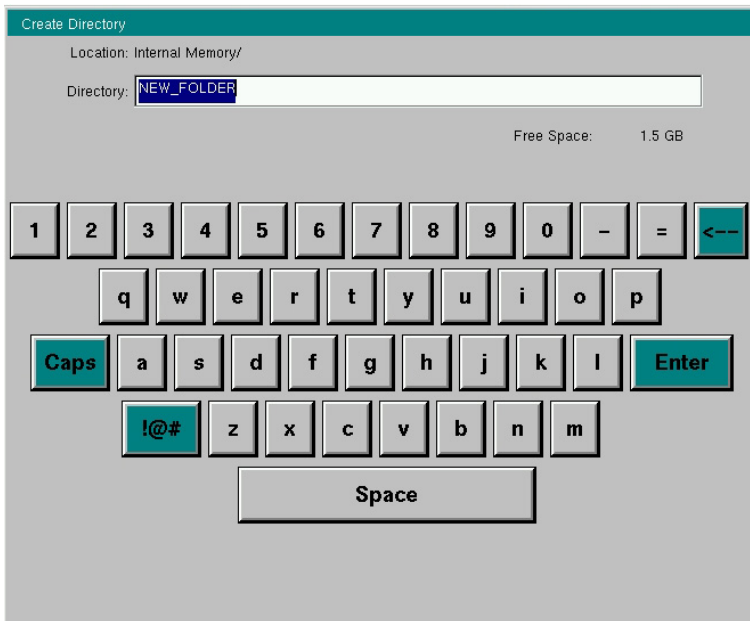


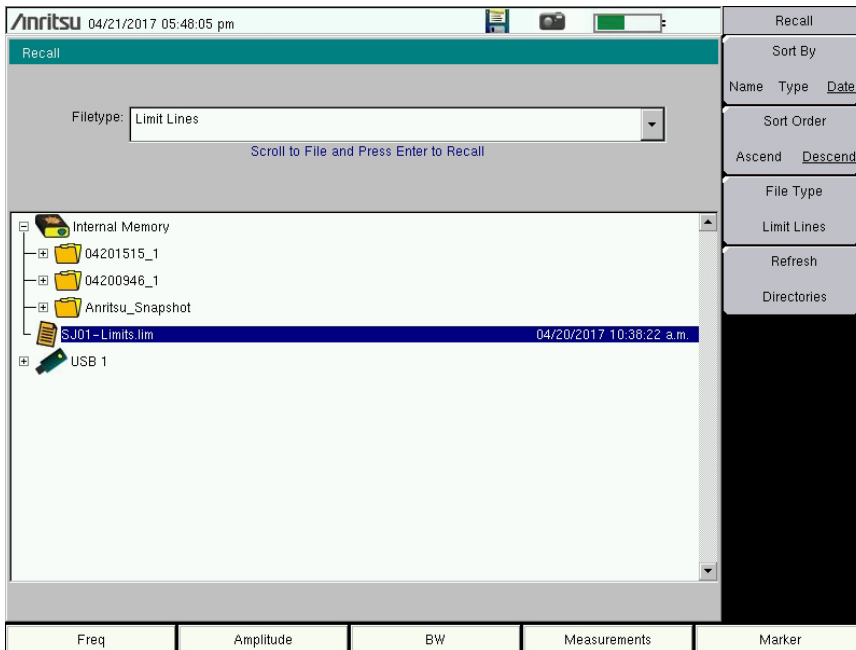
Figure 2-120. Create Directory

## 2-47 Recall Menu

Key Sequence: **Shift > Limit (6) > Recall Limit**

Recall	<p>You can recall a previously saved Limit Lines file from internal memory or a USB storage device. Select the file in the Recall dialog, then press <b>Enter</b>.</p> <p><b>Sort By</b>  <b>Name Type Date:</b> Press this key to choose the item by which folders and files are sorted in the Recall dialog box. See <a href="#">Figure 2-122</a>.</p> <p><b>Sort Order</b>  <b>Ascend Descend:</b> Press this key to toggle the sort order of the file list between Ascending and Descending.</p> <p><b>File Type</b>  <b>Limit Lines:</b> Press this key if you want to recall a different type of file. Select the file type in the Select File Type list box illustrated in <a href="#">Figure 2-123</a>, then press <b>Enter</b> to apply the selection.</p> <p>Alternatively, you can select directly from the Filetype drop down list in the Recall dialog. JPEG image files cannot be recalled and are not listed.</p> <p><b>Refresh Directories:</b> Press this key to update the file list after connecting or disconnecting an external USB device.</p>
Sort By	
Name Type Date	
Sort Order	
Ascend Descend	
File Type	
Limit Lines	
Refresh	
Directories	

**Figure 2-121.** Recall Limit Menu



**Figure 2-122.** Recall Dialog

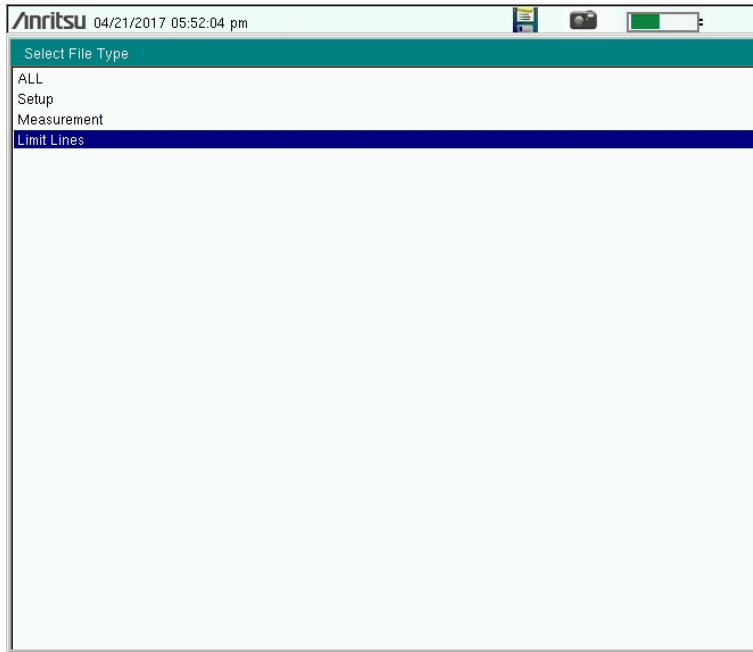


Figure 2-123. Select File Type



# Index

## Numerics

2nd harmonic .....	2-30
2x2 MIMO .....	2-30
2x4 MIMO .....	2-30
7th order intermodulation .....	2-29

## A

aggregation .....	2-6, 2-69, 2-70, 2-71
Amplitude menu .....	2-51
Anritsu, contact .....	1-2
Auto Detect .....	2-8
menu .....	2-71
screen .....	2-8
AxC container. See AxC group	
AxC group .....	2-5, 2-31, 2-73

## B

bandwidth .....	2-5, 2-31, 2-72
BBU	
emulation .....	2-14, 2-55
RET test .....	2-14, 2-19
RET Test menu .....	2-60
RF test .....	2-25
RF Test menu .....	2-61
script .....	2-15, 2-56
test .....	2-17, 2-58
BW menu .....	2-52

## C

capture IQ data .....	2-53
change directory .....	2-92
configuration	
CPRI Config menu .....	2-66
PIM over CPRI .....	2-30, 2-34
contacting Anritsu .....	1-2

## CPRI

aggregation .....	2-6, 2-69, 2-70, 2-71
Auto Detect .....	2-8
Auto Detect menu .....	2-71
Auto Detect screen .....	2-8
AxC group .....	2-5, 2-73
bandwidth .....	2-5, 2-31, 2-72
Config menu .....	2-66
Custom Settings menu .....	2-70
IQ bit width .....	2-6, 2-70, 2-71
line rate .....	2-4, 2-31, 2-67
Measurements menu map .....	2-40
menu map .....	2-38
PIM over CPRI menu .....	2-80
Radio Presets menu .....	2-68
reserve bits .....	2-6, 2-70, 2-71
SFP Data menu .....	2-78
Spectrogram menu .....	2-75
create folder .....	2-94
Custom Settings menu .....	2-70

## D

delta marker .....	2-82
--------------------	------

## F

Freq menu .....	2-47
-----------------	------

## I

IQ	
bit width .....	2-6, 2-70, 2-71
data capture .....	2-53
data playback .....	2-53
mapping .....	2-7, 2-70
save data .....	2-53

## L

Limit	
recall .....	2-96
save .....	2-92
Limit menu .....	2-90
Limit menu map .....	2-46
Limit Move menu .....	2-91
line rate .....	2-4, 2-31, 2-67
links, contact .....	1-2
LTE waveform .....	2-15, 2-55, 2-62

## M

mapping method .....	2-7, 2-70
Marker menu .....	2-82

Max Hold submenu key ..... 2-87

Measure menu ..... 2-53

menu

- Amplitude ..... 2-51
- Auto Detect ..... 2-71
- BBU RET Test ..... 2-60
- BBU RF Test ..... 2-61
- BW ..... 2-52
- CPRI Config ..... 2-66
- CPRI SFP Data ..... 2-78
- Custom Settings ..... 2-70
- Freq ..... 2-47
- Limit ..... 2-90
- Limit Move ..... 2-91
- Marker ..... 2-82
- Measure ..... 2-53
- PIM over CPRI ..... 2-80
- Radio Presets ..... 2-68
- Recall ..... 2-96
- Save ..... 2-92
- Save Location ..... 2-94
- Span ..... 2-50
- Spectrogram ..... 2-75
- Sweep ..... 2-85
- Trace ..... 2-86
- Trace A Ops ..... 2-87
- Trace B Ops ..... 2-88
- Trace C Ops ..... 2-89

menu map ..... 2-38

- Limit ..... 2-46
- Measurements ..... 2-40
- Sweep ..... 2-45
- Trace ..... 2-45

Min Hold submenu key ..... 2-87

**O**

Option 751 ..... 2-1

Option 752 ..... 2-1

Option 754 ..... 2-29

Option 759 ..... 2-1

Option 760 ..... 2-14, 2-55

Option 761 ..... 2-14, 2-60

**P**

PIM over CPRI ..... 2-29

- advanced settings ..... 2-80
- alarm ..... 2-80
- antenna configuration ..... 2-30
- configuration ..... 2-30, 2-34
- correlated PIM ..... 2-37
- generate report ..... 2-80
- measurement ..... 2-34
- measurement state ..... 2-36
- menu ..... 2-80
- PIM desensitization .. 2-31, 2-36, 2-80
- reset measurements ..... 2-37, 2-80
- site configuration ..... 2-30

**Q**

Quick Name ..... 2-92

**R**

radio preset

- PIM over CPRI ..... 2-32
- Radio Presets menu ..... 2-68

Recall limit ..... 2-96

refresh directories ..... 2-94, 2-96

Remote Electrical Tilt. See RET

reserve bits ..... 2-6, 2-70, 2-71

reserve containers ..... 2-5, 2-69, 2-70

reset measurements ..... 2-37, 2-80

RET

- alarms ..... 2-60
- antenna tilt ..... 2-22
- antenna type ..... 2-22
- clear alarms ..... 2-20
- device calibration ..... 2-20, 2-60
- device configuration ..... 2-20, 2-60
- device update ..... 2-19, 2-60
- generate report ..... 2-24, 2-60
- get alarms ..... 2-19
- self test ..... 2-60
- test ..... 2-14, 2-19
- Test menu ..... 2-60

RF Test menu ..... 2-61

**S**

sample width ..... 2-6, 2-70, 2-71

sampling rate ..... 2-73

Save

- limit ..... 2-92
- location ..... 2-94

save IQ data ..... 2-53

script ..... 2-15, 2-56

self-PIM interference ..... 2-29

SFP

- compliance info ..... 2-78
- Data menu ..... 2-78
- port selection ..... 2-73

SISO ..... 2-30

site configuration ..... 2-30

Span menu ..... 2-50

Spectrogram menu ..... 2-75

Sweep menu ..... 2-85

Sweep menu map ..... 2-45

**T**

Trace A Ops menu ..... 2-87

Trace B Ops menu ..... 2-88

Trace C Ops menu ..... 2-89

Trace menu ..... 2-86

Trace menu map ..... 2-45

**U**

uplink

- under test ..... 2-32, 2-80

**W**

waveform ..... 2-15, 2-55, 2-62

web links, contact ..... 1-2





# Anritsu



Anritsu utilizes recycled paper and environmentally conscious inks and toner.

Anritsu Company  
490 Jarvis Drive  
Morgan Hill, CA 95037-2809  
USA  
<http://www.anritsu.com>